



24 July 2023

(23-5040)

Page: 1/2

Committee on Technical Barriers to Trade

Original: English

NOTIFICATION

The following notification is being circulated in accordance with Article 10.6

| |
|---|
| 1. Notifying Member: <u>KINGDOM OF SAUDI ARABIA</u> If applicable, name of local government involved (Article 3.2 and 7.2): |
| 2. Agency responsible: Saudi Standards, Metrology and Quality Organization (SASO) Name and address (including telephone and fax numbers, email and website addresses, if available) of agency or authority designated to handle comments regarding the notification shall be indicated if different from above: Saudi Standards, Metrology and Quality Organization (SASO) " P. O .BOX : 3437 Riyadh 11471 " Tel: +966(11) 252 Ext : (9065-9081-9072) " Fax +966(11) 4520193 , +966(11)4520086 Email: enquiry@sas.gov.sa Website: http://www.saso.gov.sa |
| 3. Notified under Article 2.9.2 [X], 2.10.1 [], 5.6.2 [], 5.7.1 [], 3.2 [], 7.2 [], other: |
| 4. Products covered (HS or CCCN where applicable, otherwise national tariff heading. ICS numbers may be provided in addition, where applicable): Road vehicle tyres (ICS code(s): 83.160.10) |
| 5. Title, number of pages and language(s) of the notified document: SASO ECE 117: Uniform provisions concerning the approval of tyres with regard to rolling sound emissions and/or to adhesion on wet surfaces and/or to rolling resistance |
| 6. Description of content: This Regulation applies to new pneumatic tyres* of Classes C1, C2 and C3 with regard to their sound emissions, rolling resistance and to adhesion performance on wet surfaces (wet adhesion). |
| 7. Objective and rationale, including the nature of urgent problems where applicable: This document is update of SASO ECE 117:2015 "Uniform provisions concerning the approval of tyres with regard to rolling sound emissions and/or to adhesion on wet surfaces and/or to rolling resistance" by adoption of the Technical regulation issued by the European Economic Commission at the United Nations No. ECE 117:2016 until ECE 117:2016/Amd7:2023.; Consumer information, labelling; Quality requirements; Consumer information, labelling; Quality requirements |
| 8. Relevant documents: SASO-2857: Vehicle tires rolling resistance and wet grip requirements |

| | |
|------------|--|
| 9. | Proposed date of adoption: 16 July 2023 Proposed date of entry into force: 6 months from adoption |
| 10. | Final date for comments: 60 days from notification |
| 11. | Texts available from: National enquiry point [] or address, telephone and fax numbers and email and website addresses, if available, of other body: Saudi Standards, Metrology, Quality Organization (SASO) P.O. Box 3437 Riyadh 11471 +966(11)252; ext:9065; ext.9081; ext.9072 +966 (1) 4530035 (Fax) ENQUIRYPOINT@saso.gov.sa http://www.saso.gov.sa |

السعودية للمواصفات و المقاييس و الجودة
Saudi Standards, Metrology and Quality Org. (SASO)



SASO FDS/ECE 117:2023

الأحكام الموحدة المتعلقة بالموافقة على الإطارات فيما يتعلق بالانبعاثات الصوتية و/أو التماسك على الأسطح الرطبة و/أو مقاومة الدوران

Uniform provisions concerning the approval of tyres with regard to rolling sound emissions and/or to adhesion on wet surfaces and/or to rolling resistance

ICS: 83.160.10

مقدمة

قامت الهيئة السعودية للمواصفات والمقاييس والجودة بتحديث المواصفة السعودية رقم SASO ECE 117:2015 الأحكام الموحدة المتعلقة بالموافقة على الإطارات فيما يتعلق بالانبعاثات الصوتية و/أو التماسك على الأسطح الرطبة و/أو مقاومة الدوران و ذلك بتبني اللائحة الفنية الصادرة عن اللجنة الاقتصادية الأوروبية في الأمم المتحدة رقم ECE 117:2016 إلى ECE 117:2016/Amd7:2023 على أن تلغى المواصفة السعودية رقم SASO ECE 117:2015 و تحل محلها.

Foreword

Saudi Standards, Metrology and Quality Organization (SASO) has updated the Saudi standard No. SASO ECE 117:2015 Uniform provisions concerning the approval of tyres with regard to rolling sound emissions and/or to adhesion on wet surfaces and/or to rolling resistance by adoption of the Technical regulation issued by the European Economic Commission at the United Nations No. ECE 117:2016 until ECE 117:2016/Amd7:2023. The approved Saudi standard will replace and supersede the Saudi standard No. SASO ECE 117:2015.

22 February 2017

Agreement

Concerning the Adoption of Uniform Technical Prescriptions for Wheeled Vehicles, Equipment and Parts which can be Fitted and/or be Used on Wheeled Vehicles and the Conditions for Reciprocal Recognition of Approvals Granted on the Basis of these Prescriptions*

(Revision 2, including the amendments which entered into force on 16 October 1995)

Addendum 116 – Regulation No. 117

Revision 4 - Amendment 1

Supplement 9 to the 02 series of amendments – Date of entry into force: 9 February 2017

Uniform provisions concerning the approval of tyres with regard to rolling sound emissions and/or to adhesion on wet surfaces and/or to rolling resistance

This document is meant purely as documentation tool. The authentic and legal binding text is: ECE/TRANS/WP.29/2016/60.



UNITED NATIONS

* Former title of the Agreement: Agreement Concerning the Adoption of Uniform Conditions of Approval and Reciprocal Recognition of Approval for Motor Vehicle Equipment and Parts, done at Geneva on 20 March 1958.

Paragraph 1.1., amend to read:

"1.1. This Regulation applies to new pneumatic tyres* of Classes C1, C2 and C3 with regard to their sound emissions, rolling resistance and to adhesion performance on wet surfaces (wet adhesion). It does not, however, apply to:

* For the purpose of this Regulation "tyres" means "pneumatic tyres"

Paragraph 2.1., amend to read:

"2.1. "Type of tyre" means which do not differ in such essential characteristics as:

- (a) The manufacturer's name;
- (b)"

Add a new paragraph 2.2. to read:

"2.2. "Manufacturer" means the person or body who is responsible to the Type Approval Authority (TAA) for all aspects of the type-approval and for ensuring the conformity of production."

Paragraph 2.3., amend to read:

"2.3. "Brand name/trademark" means the identification of the brand or trademark as defined by the tyre manufacturer and marked on the sidewall(s) of the tyre. The Brand name/trademark may be the same as that of the Manufacturer."

Renumber paragraph 2.3. as 2.5.

Add a new paragraph 2.4. to read:

"2.4. Trade description/commercial name: means an identification of a range of tyres as given by the tyre manufacturer. It may coincide with the brand name/trademark."

Renumber 2.4. to 2.8. as paragraphs 2.6. to 2.10.

Paragraph 2.9.(former), amend to read:

"2.11. "Reinforced tyre" or "extra-load tyre" of Class C1 means a tyre structure designed..."

Renumber paragraphs 2.10. to 2.18. as paragraphs 2.12. to 2.20.

Paragraph 3.1.2., amend to read:

"3.1.2. Manufacturer's name;"

Paragraph 3.1.5., amend to read:

"3.1.5. Brand name(s)/trademark(s), trade description(s)/commercial name(s);"

Paragraph 3.5., shall be deleted

Paragraph 4.2.1., amend to read:

"4.2.1. The manufacturer's name or the Brand name/trademark;"

Paragraph 4.2.2., amend to read:

"4.2.2. The trade description/commercial name (see paragraph 2.4. of this Regulation). However, the trade description is not required when it coincides with the Brand name/trademark;"

Paragraph 7., amend to read:

"7. Modifications of the type of tyre and extension of approval"

Paragraph 10., amend to read:

"10. Production definitively discontinued

If the holder of an approval completely ceases to manufacture a type of tyre approved in accordance..."

Add a number of a paragraph to the first alinea and amend to read:

"11.1. The Contracting Parties to the 1958 Agreement which apply this Regulation shall communicate to the United Nations Secretariat, the names and addresses of the Technical Services responsible for conducting approval tests and, where applicable, of the approved test laboratories and of the Type Approval Authorities which grant approval and to which forms certifying approval or extension of approval or refusal of approval or withdrawal of approval, or production definitively discontinued, issued in other countries, are to be sent."

Add a new paragraph 11.2. to read:

"11.2. The Contracting Parties to the 1958 Agreement which apply this Regulation may designate laboratories of tyre manufacturers as approved test laboratories."

Add a new paragraph 11.3. to read:

"11.3. Where a Contracting Party to the 1958 Agreement applies paragraph 11.2. Above, it may, if it so desires, be represented at the tests by one or more persons of its choice."

Annex 1,

Item 1. amend to read:

"1. Manufacturer's name and address:"

Item 4. amend to read:

"4. Tyre type designation:

4.1. Brand-name(s)/trademark(s) of the type of tyre:

4.2. Trade description(s)/ Commercial name(s) of the type of tyre:"

Item 5. amend to read:

"5. Technical service and, where applicable, test laboratory approved for purposes of approval or of verification of conformity tests:"

Item 14.2. amend to read:

"14.2. A list of tyre size designations: Specify for each brand name/trademark and/or each trade description/ Commercial name the list of tyre size designations, adding..."

Annex 2,

Appendix 1, Example 1, amend to read:

"The above approval mark, affixed to a tyre shows that a tyre concerned..."

Annex 3,

Paragraph 2.5.3., amend to read:

"2.5.3. Tyre inflation pressure

Each tyre fitted on the test vehicle shall have a test pressure P_t not higher than the reference pressure P_r and within the interval:

$$P_r \cdot \left(\frac{Q_t}{Q_r}\right)^{1.25} \leq P_t \leq 1.1 \cdot P_r \cdot \left(\frac{Q_t}{Q_r}\right)^{1.25}$$

For Class C2 and Class C3 the reference pressure P_r is the inflation pressure corresponding to the pressure in kPa or to the pressure index marked on the sidewall.

For Class C1 the reference pressure is $P_r = 250$ kPa for "standard" tyres and 290 kPa for "reinforced" or "extra load" tyres; the minimum test pressure shall be $P_t = 150$ kPa."

29 January 2020

Agreement

Concerning the Adoption of Harmonized Technical United Nations Regulations for Wheeled Vehicles, Equipment and Parts which can be Fitted and/or be Used on Wheeled Vehicles and the Conditions for Reciprocal Recognition of Approvals Granted on the Basis of these United Nations Regulations*

(Revision 3, including the amendments which entered into force on 14 September 2017)

Addendum 116 – UN Regulation No. 117

Revision 4 - Amendment 2

Supplement 10 to the 02 series of amendments – Date of entry into force: 11 January 2020

Uniform provisions concerning the approval of tyres with regard to rolling sound emissions and/or to adhesion on wet surfaces and/or to rolling resistance

This document is meant purely as documentation tool. The authentic and legal binding text is: ECE/TRANS/WP.29/2019/54.



UNITED NATIONS

* Former titles of the Agreement:

Agreement concerning the Adoption of Uniform Conditions of Approval and Reciprocal Recognition of Approval for Motor Vehicle Equipment and Parts, done at Geneva on 20 March 1958 (original version); Agreement concerning the Adoption of Uniform Technical Prescriptions for Wheeled Vehicles, Equipment and Parts which can be Fitted and/or be Used on Wheeled Vehicles and the Conditions for Reciprocal Recognition of Approvals Granted on the Basis of these Prescriptions, done at Geneva on 5 October 1995 (Revision 2).



Paragraph 2.1., amend to read:

"2.1. "Type of tyre" means tyres which do not differ in such essential characteristics as:"

Paragraph 5. and its subparagraphs, amend to read:

"5. Approval

5.1. If the representative tyre size of the type of tyre submitted for approval pursuant to this Regulation meets the requirements of paragraphs 6. and 7. below, approval of that type of tyre shall be granted.

5.2. An approval number according to Schedule 4 to the Revision 3 of the 1958 Agreement shall be assigned to the type of tyre approved. The same Contracting Party may not assign the same number to another type of tyre.

5.2.1. Instead of granting the original type approval number pursuant to UN Regulation No. 117, upon the request of the manufacturer, the Type Approval Authority may grant the type approval number, which had been granted before to that type of tyre pursuant to UN Regulations Nos. 30 or 54 with the subsequent extension number.

5.2.2. The communication form mentioned in paragraph 5.3. below shall identify specific performance parameters of UN Regulation No. 117 by the following suffixes:

S To identify additional conformity to the requirements on tyre rolling sound emissions;

W To identify additional conformity to the requirements on tyre adhesion on wet surfaces;

R To identify additional conformity to the requirements on tyre rolling resistance.

Taking into account that two stages are defined for rolling sound and rolling resistance specifications in paragraphs 6.1. and 6.3. below, S and R will be followed either by the suffix "1" for compliance to stage 1 or by the suffix "2" for compliance to stage 2.

5.3. Notice of approval or extension of approval or refusal of approval of a type of tyre pursuant to this Regulation shall be communicated to the Parties to the Agreement, which apply this Regulation by means of a form conforming to the model in Annex 1 to the Regulation.

5.3.1. With reference to paragraph 5.2.1. above, tyre manufacturers are entitled to submit an application for extension of type approval to the requirements of other Regulations relevant to the tyre type. In that case, a copy of the relevant type approval communication(s), as issued by the relevant Type Approval Authority, shall be attached to the application for extension of approval. All applications for extension of approval(s) shall only be granted by the Type Approval Authority which issued the original approval for the tyre.

5.3.1.1. When extension of approval is granted to incorporate into the communication form (see Annex 1 to this Regulation) certification(s) of conformity to other Regulations, (all) the specific type approval number(s) and the Regulation itself shall be added to item 9. of Annex 1 "Communication form".

- 5.3.1.2. The suffix(es) mentioned in paragraph 5.2.2. above shall be preceded by the two digits identifying the series of amendments of the prescription on tyre performances for UN Regulation No. 117, e.g. 02S2 to identify the second series of amendments on tyre road rolling sound emissions at stage 2 or 02S1WR1 to identify the second series of amendments on tyre road rolling sound emissions at stage 1, tyre adhesion on wet surfaces and rolling resistance at stage 1 (see paragraph 6.1. below for stage 1 and stage 2 definitions).
- 5.4. In the space referred to in paragraph 4.3. and in accordance with the requirements of paragraph 4.4. above there shall be affixed to every tyre size, conforming to the type of tyre approved under this Regulation, an international approval mark consisting of:
 - 5.4.1. A circle surrounding the letter "E" followed by the distinguishing number of the country which has granted approval;¹² and
 - 5.4.2. The part of the approval number specified in paragraph 3 Section 3 of Schedule 4 to the Revision 3 of the 1958 Agreement, which shall be placed close to the circle prescribed in paragraph 5.4.1. above either above or below the "E" or to the left or right of that letter.
 - 5.4.3. ... "

(Footnote 12 remains unchanged).

Annex 1 "Communication", introductory part, amend to read:

"Annex 1

Communication

(Maximum format: A4 (210 x 297 mm))



Issued by: Name of administration:

.....
.....
.....

Concerning:² Approval granted
Approval extended
Approval refused
Approval withdrawn
Production definitively discontinued

of a type of tyre with regard to "rolling sound emission level" and/or "adhesion performance on wet surfaces" and/or "rolling resistance" pursuant to UN Regulation No. 117

Approval No³ Suffix(es)⁴

1. ...

...

¹ Distinguishing number of the country which has granted/extended/refused/withdrawn approval (see approval provisions in this Regulation).

² Strike out what does not apply.

³ According to Schedule 4 to Revision 3 of the 1958 Agreement.

⁴ According to paragraphs 5.2.2. and 5.3.1.2. of this Regulation."

Annex 7, Appendix 2, Part 2, paragraph 5., amend to read:

"5. Test results: mean fully developed decelerations (m/s²) / traction coefficient¹

| <i>Run number</i> | <i>Specification</i> | <i>SRTT</i> <i>(1st test)</i> | <i>Candidate</i> | <i>Candidate</i> | <i>SRTT</i> <i>(2nd test)</i> |
|-------------------|----------------------|----------------------------------|------------------|------------------|----------------------------------|
| 1 | | | | | |
| 2 | | | | | |
| 3 | | | | | |
| 4 | | | | | |
| 5 | | | | | |
| 6 | | | | | |
| | | | | | |
| | | | | | |
| | | | | | |
| Mean | | | | | |
| Std-deviation | | | | | |
| CV (%) | < 6 % | | | | |
| Validation SRTT | (SRTT) ≤ 5 % | | | | |
| SRTT average | | | | | |
| Snow grip index | | 1.00 | | | |

"

¹ Strike out what does not apply.

4 November 2020

Agreement

Concerning the Adoption of Harmonized Technical United Nations Regulations for Wheeled Vehicles, Equipment and Parts which can be Fitted and/or be Used on Wheeled Vehicles and the Conditions for Reciprocal Recognition of Approvals Granted on the Basis of these United Nations Regulations*

(Revision 3, including the amendments which entered into force on 14 September 2017)

Addendum 116 – UN Regulation No. 117

Revision 4 - Amendment 3

Supplement 11 to the 02 series of amendments – Date of entry into force: 25 September 2020

Uniform provisions concerning the approval of tyres with regard to rolling sound emissions and/or to adhesion on wet surfaces and/or to rolling resistance

This document is meant purely as documentation tool. The authentic and legal binding text is: ECE/TRANS/WP.29/2020/6 (as amended by paragraph 85 of the report ECE/TRANS/WP.29/1151).



UNITED NATIONS

* Former titles of the Agreement:

Agreement concerning the Adoption of Uniform Conditions of Approval and Reciprocal Recognition of Approval for Motor Vehicle Equipment and Parts, done at Geneva on 20 March 1958 (original version); Agreement concerning the Adoption of Uniform Technical Prescriptions for Wheeled Vehicles, Equipment and Parts which can be Fitted and/or be Used on Wheeled Vehicles and the Conditions for Reciprocal Recognition of Approvals Granted on the Basis of these Prescriptions, done at Geneva on 5 October 1995 (Revision 2).

Paragraph 2.1., amend to read:

- "2.1. "Type of tyre" means tyres which do not differ in such essential characteristics as:
- (a) The manufacturer's name;
 - (b) The tyre class (see paragraph 2.4. below);
 - (c) The tyre structure;
 - (d) The category of use: normal tyre, snow tyre and special use tyre;
 - (e) Whether tyre for use in severe snow conditions or not;
 - (f) For Classes C2 and C3 tyres, whether traction tyre or not;
 - (g) The tread pattern (see paragraph 3.2.1. of this Regulation)."

Paragraph 2.18., amend to read:

- "2.18. "Standard Reference Test Tyre (SRTT)" means a tyre that is produced, controlled and stored in accordance with the American Society for Testing and Materials (ASTM) standards
- (a) E1136 – 17 for the size P195/75R14 and referred to as "SRTT14",
 - (b) F2872 – 16 for the size 225/75R16C and referred to as "SRTT16C",
 - (c) F2871 – 16 for the size 245/70R19.5 and referred to as "SRTT19.5",
 - (d) F2870 – 16 for the size 315/70R22.5 and referred to as "SRTT22.5",
 - (e) F2493 – 18 for the size P225/60R16 and referred to as "SRTT16"."

Paragraph 2.19.1., amend to read:

- "2.19.1. "Adhesion on wet surfaces" means the relative braking performance, on a wet surface, of a test vehicle equipped with the candidate tyre in comparison to that of the same test vehicle equipped with a Standard Reference Test Tyre (SRTT)."

Paragraph 2.20.1., amend to read:

- "2.20.1. "Rolling resistance F_r " means the loss of energy (or energy consumed) per unit of distance travelled.³"

Paragraph 2.20.3., amend to read:

- "2.20.3. "New test tyre" means a tyre which has not been previously used in a rolling deflected test which elevates the tyre's temperature to higher than that generated in rolling resistance tests, and which has not previously been exposed to a temperature above 40 °C.^{5,6}"

Paragraph 2.20.5., amend to read:

- "2.20.5. "Capped inflation" means the process of inflating the tyre to the required cold inflation pressure and allowing the inflation pressure to build up, as the tyre is warmed up while running."

Paragraph 2.20.8., amend to read:

- "2.20.8. "Inertia" or "moment of inertia" means the ratio of the torque applied to a rotating body, such as a tyre assembly or machine drum, to the rotational acceleration of this body.⁸"

Paragraphs 3.1.2. to 3.1.10., amend to read and renumber:

- "3.1.2. Manufacturer's name and address;
- 3.1.3. If applicable, name and address of manufacturer's representative;
- 3.1.4. Tyre class (Class C1, C2 or C3) (see paragraph 2.6. of this Regulation);

- 3.1.5. Category of use (normal, snow, or special);
- 3.1.5.1. Whether tyre for use in severe snow conditions or not;
- 3.1.5.2. For Class C2 and C3 tyres, whether traction tyre or not;
- 3.1.6. Tyre structure;
- 3.1.7. Brand name(s)/trademark(s), trade description(s)/commercial name(s);
- 3.1.8. A list of tyre size designations covered by this application and specifying for each brand name/trademark and/or each trade description/commercial name the applicable tyre size designations and service descriptions, adding in case of Class C1 tyres whether "reinforced" (or "extra load") or not."

Paragraph 3.4., amend to read:

- "3.4. With regard to the application, testing may be confined to a representative tyre size of the type of tyre, at the discretion of the Type Approval Authority."

Paragraph 6.2., amend to read:

- "6.2. The wet grip performance will be based on a procedure that compares either peak brake force coefficient ("pbfc") or mean fully developed deceleration ("mfdd") against values achieved by a Standard Reference Test Tyre (SRTT). The relative performance shall be indicated by a wet grip index (G)."

Paragraph 6.4., amend to read:

- "6.4. In order to be classified as a "snow tyre for use in severe snow conditions" the tyre shall meet the performance requirements of paragraph 6.4.1. below. The tyre shall meet these requirements based on a test method of Annex 7 by which:
 - (a) The mean fully developed deceleration ("mfdd") in a braking test;
 - (b) Or alternatively an average traction force in a traction test;
 - (c) Or alternatively the average acceleration in an acceleration test
 of the candidate tyre is compared to that of a Standard Reference Test Tyre (SRTT).
The relative performance shall be indicated by a snow grip index."

Paragraph 6.4.1.1., amend to read:

- "6.4.1.1. Class C1, C2 and C3 tyres
The minimum snow grip index value, as calculated in the procedure described in Annex 7 and compared with the respective Standard Reference Test Tyre (SRTT) shall be as follows:

| Class of tyre | Snow grip index (brake on snow method) ^(a) | | Snow grip index (spin traction method) ^(b) | Snow grip index (acceleration method) ^(c) |
|---------------|---|----------------|---|--|
| | Ref. = SRTT14 | Ref. = SRTT16C | Ref. = SRTT14 | Ref.s = SRTT19.5, SRTT22.5 |
| C1 | 1.07 | No | 1.10 | No |
| C2 | No | 1.02 | 1.10 | No |
| C3 | No | No | No | 1.25 |

(a) See paragraph 3. of Annex 7 to this Regulation
(b) See paragraph 2. of Annex 7 to this Regulation
(c) See paragraph 4. of Annex 7 to this Regulation"

Insert a new paragraph 12.9. to read:

"12.9. Until 3 months after the date of entry into force of Supplement 11 to the 02 series of amendments to this Regulation, Contracting Parties applying this Regulation can continue to grant type approvals according to the 02 series of amendments to this Regulation, without taking into account the provisions of Supplement 11."

Annex 1

Item 3., amend to read:

"...

3. "Tyre class" of the type of tyre:"

Items 3.1. and 3.2., renumber to 4.1. and 4.2.

Insert new items 4. and 5. to read:

"4. "Category of use" of the type of tyre:"

4.1. Snow tyre for use in severe snow conditions (Yes/No)²

4.2. Traction tyre (Yes/No)²

5. Tyre structure:"

Items 4. to 14.2., renumber as 6. to 16.2., respectively.

Items 8.1. to 8.4. (new), amend to read:

"8.1. Sound level of the representative tyre size, see paragraph 2.7. of this Regulation, as per item 7. of the test report in Appendix 1 to Annex 3: dB(A) at reference speed of 70/80 km/h²

8.2. Wet adhesion level of the representative tyre size, see paragraph 2.7. of this Regulation, as per item 7. of the test report in the appendix to Annex 5: (G) using the vehicle or trailer method²

8.3. Rolling resistance level of the representative tyre size, see paragraph 2.7. of this Regulation, as per item 7. of the test report in Appendix 1 to Annex 6.....

8.4. Snow grip level of the representative tyre size, see paragraph 2.7. of Regulation No. 117, as per item 7. of the test report in the appendix³ to Annex 7:..... (Snow grip index) using the brake on snow method², spin traction method² or acceleration method.²"

Item 16.2. (new), amend to read:

"16.2. A list of tyre size designations: Specify for each brand name/trademark and/or each trade description/Commercial name the list of tyre size designations and service descriptions, adding in case of Class C1 tyres whether "reinforced" (or "extra load") or not."

Annex 2

Appendix 2, example 2, figure, amend to read:

"

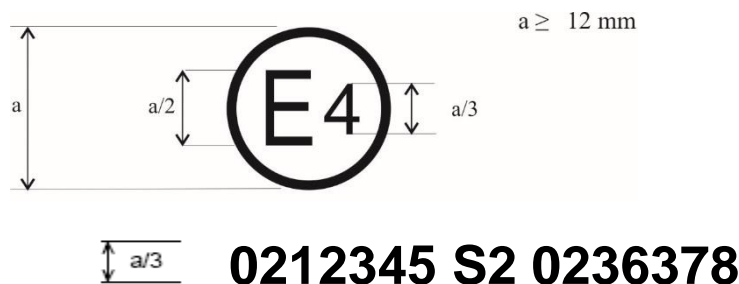

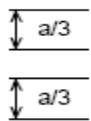
Or
 **0212345 S2WR2**
0236378

Annex 3

Paragraph 1.1., amend to read:

"1.1. Acoustic measurements

The sound level meter or the equivalent measuring system, including the windscreen recommended by the manufacturer shall meet or exceed the requirements of Type 1 instruments in accordance with IEC 61672-1:2013."

Paragraph 1.1.1., amend to read:

"1.1.1. Calibration

At the beginning and at the end of every measurement session, the entire measurement system shall be checked by means of a sound calibrator that fulfils the requirements for sound calibrators of at least precision Class 1 according to IEC 60942:2017. Without any further adjustment the difference between the readings of two consecutive checks shall be less than or equal to 0.5 dB(A). If this value is exceeded, the results of the measurements obtained after the previous satisfactory check shall be discarded."

Paragraph 4.3., renumber as 4.2. and amend to read:

"4.2. Temperature correction

For Class C1 and Class C2 tyres, the rolling sound levels $L_i(\vartheta_i)$ obtained at the test surface temperature ϑ_i (where i denotes the number of the single measurement) shall be normalized to a test surface reference temperature ϑ_{ref} by applying a temperature correction, according to the following formula:

$$L_i(\vartheta_{\text{ref}}) = L_i(\vartheta_i) + K(\vartheta_{\text{ref}} - \vartheta_i)$$

where:

$$\vartheta_{\text{ref}} = 20 \text{ }^\circ\text{C},$$

For Class C1 tyres, the coefficient K is:

- 0.03 dB(A)/ $^\circ\text{C}$ when $\vartheta_i > \vartheta_{\text{ref}}$ and
- 0.06 dB(A)/ $^\circ\text{C}$ when $\vartheta_i < \vartheta_{\text{ref}}$.

For Class C2 tyres, the coefficient K is - 0.02 dB(A)/ $^\circ\text{C}$.

Notwithstanding the above procedure, the temperature correction may be made only on the final reported tyre rolling sound level L_R , utilizing the arithmetic mean value of the measured temperatures, if the measured test surface temperature does not change more than 5 $^\circ\text{C}$ within all measurements necessary for the determination of the sound level of one set of tyres. In this case the regression analysis below shall be based on the uncorrected rolling sound levels $L_i(\vartheta_i)$.

There will be no temperature correction for Class C3 tyres."

Paragraph 4.2. (former), renumber as 4.3. and amend to read:

"4.3. Regression analysis of rolling sound measurements

The tyre-road rolling sound level $L_R(\vartheta_{\text{ref}})$ in dB(A) is determined by a regression analysis according to:

$$L_R(\vartheta_{\text{ref}}) = \bar{L} - a \cdot \bar{\tau}$$

where:

\bar{L} is the mean value of the temperature-corrected rolling sound levels $L_i(\vartheta_{\text{ref}})$, measured in dB(A):

$$\bar{L} = \frac{1}{n} \sum_{i=1}^n L_i(\vartheta_{\text{ref}})$$

n is the number of measurements ($n \geq 16$),

$\bar{\tau}$ is the mean value of logarithms of speeds V_i :

$$\bar{\tau} = \frac{1}{n} \sum_{i=1}^n \tau_i \quad \text{with} \quad \tau_i = \log_{10} \left(\frac{V_i}{V_{\text{ref}}} \right)$$

a is the slope of the regression line in dB(A):

$$a = \frac{\sum_{i=1}^n [(\tau_i - \bar{\tau})(L_i(\vartheta_{\text{ref}}) - \bar{L})]}{\sum_{i=1}^n (\tau_i - \bar{\tau})^2}$$

"

Paragraph 4.4., amend to read:

"4.4. In order to take account of any measuring instrument inaccuracies, the temperature corrected tyre rolling sound level $L_R(\vartheta_{\text{ref}})$ in dB(A) shall be reduced by 1 dB(A) and then rounded down to the nearest lower whole value to obtain the final result."

Paragraph 4.5. shall be deleted.

Annex 3 - Appendix 1, amend to read:

"...

Part 1 – Report

...

2. Name and address of manufacturer:

...

4. Brand name and trade description:

...

6. Category of use:

6.1. Tyre for use in severe snow conditions (Yes/No)¹

6.2. Traction tyre (Yes/No)¹

7. Sound level according to paragraph 4.4. of Annex 3: dB(A)
at reference speed of 70/80 km/h¹

...

Part 2 – Test data

...

4.3. Reference (test) inflation pressure²: kPa

...

5. Valid test results:

| Run No. | Test speed km/h | Direction of run | Sound level left ^a measured dB(A) | Sound level right ^a measured dB(A) | Air temp. °C | Test surface temp. °C | Sound level left ^a temp. corrected ^b dB(A) | Sound level right ^a temp. corrected ^b dB(A) | Comments |
|---------|-----------------|------------------|--|---|--------------|-----------------------|--|---|----------|
| 1 | | | | | | | | | |
| 2 | | | | | | | | | |
| 3 | | | | | | | | | |
| 4 | | | | | | | | | |
| 5 | | | | | | | | | |
| 6 | | | | | | | | | |
| 7 | | | | | | | | | |
| 8 | | | | | | | | | |

^a Relative to the vehicle.

^b Omit, if regression according to paragraph 4.3. of Annex 3 is made on the uncorrected rolling sound level values.

5.1. Regression line slope:

5.2. Sound level according to paragraph 4.3. of Annex 3:

..... dB(A)"

Annex 3 - Appendix 1, add a new footnote 2:

"² for C2 and C3 tyres, corresponding to the indication of the inflation pressure marked on the sidewall as required by paragraph 4.1. of this Regulation"

Annex 5, part A

Paragraphs 1.4 and 1.5., delete.

Paragraph 2.4., amend to read:

"2.4. "Reference tyre(s) (R)" means a tyre or a tyre set of Standard Reference Test Tyres SRTT16."

Paragraphs 2.12. and 2.13. shall be deleted.

Paragraph 3.2.2., amend to read:

"3.2.2. Standard Reference Test Tyre method

This method uses the Standard Reference Test Tyre SRTT14.

Perform at least six (6) valid measurements of the peak braking force coefficient with the SRTT14 using the trailer towed by a vehicle or a tyre test vehicle test procedure as specified in clause 4.2. (at 65 km/h and 180 kPa).

The average ($\mu_{\text{peak,ave}}$) of the measured peak braking force coefficients shall be corrected for the effects of temperature as follows:

$$\mu_{\text{peak,corr}} = \mu_{\text{peak,ave}} + 0.0035 \cdot (t - 20)$$

where t is the wetted road surface temperature in degrees Celsius.

The temperature corrected average peak braking force coefficient ($\mu_{\text{peak,corr}}$) shall be 0.7 ± 0.1 ."

Paragraph 4.1.6.2., first sentence, amend to read:

" The AD coefficient of variation CV_{AD} is calculated as follows:

$$CV_{AD} = 100\% \cdot \frac{\sigma_{AD}}{AD}$$

where

$\sigma_{AD} = \sqrt{\frac{1}{N-1} \sum_{i=1}^N (AD_i - \overline{AD})^2}$ denotes the corrected sample standard deviation and

\overline{AD} the arithmetic mean of the Average Decelerations (AD_i) of N test runs."

Paragraph 4.1.7.3., amend to read:

"4.1.7.3. Storage and preservation

It is necessary that all the tyres of a control tyre set have been stored in the same conditions. As soon as the control tyre set has been tested in comparison with the reference tyre, the specific storage conditions defined in ASTM E1136 – 17 shall be applied."

Paragraph 4.2.8.2., first sentence, amend to read:

" The μ_{peak} coefficient of variation CV_{μ} is calculated as follows:

$$CV_{\mu} = 100\% \cdot \frac{\sigma_{\mu}}{\mu_{\text{peak}}}$$

where

$\sigma_{\mu} = \sqrt{\frac{1}{N-1} \sum_{i=1}^N (\mu_{\text{peak},i} - \overline{\mu_{\text{peak}}})^2}$ denotes the corrected sample standard deviation and

$\overline{\mu_{\text{peak}}}$ the arithmetic mean of the peak braking force coefficients ($\mu_{\text{peak},i}$) of N test runs."

Annex 5, part B

Paragraph 1.1.1., amend to read:

"1.1.1. Standard Reference Test Tyre (SRTT) method

This method uses the Standard Reference Test Tyre SRTT14.

Perform at least six (6) valid measurements of the peak braking force coefficients with the Standard Reference Test Tyre SRTT14 using the trailer or special purpose tyre evaluation vehicle test procedure as specified in clause 2.1. (at 65 km/h and 180 kPa).

The average ($\mu_{\text{peak,ave}}$) of the measured peak braking force coefficients shall be corrected for the effects of temperature as follows:

$$\mu_{\text{peak,corr}} = \mu_{\text{peak,ave}} + 0.0035 \cdot (t - 20)$$

where t is the wetted track surface temperature in degrees Celsius.

The temperature corrected average peak braking force coefficient ($\mu_{\text{peak,corr}}$) shall be 0.7 ± 0.1 .

The test shall be conducted using the lanes and length of the track to be used for the wet grip test.

For the trailer method, testing is run in such a way that braking occurs within 10 meters distance of where the surface was characterized."

Paragraph 1.4., amend to read:

"1.4. In order to cover the range of the tyre sizes fitting the commercial vehicles, the Standard Reference Test Tyres (SRTT) shall be used to measure the relative wet index as shown in the following table:

| For C3 tyres | |
|---------------|-------------|
| Narrow family | Wide family |

| | |
|--|--|
| $S_{\text{Nominal}} < 285 \text{ mm}$ | $S_{\text{Nominal}} \geq 285 \text{ mm}$ |
| SRTT19.5 | SRTT22.5 |
| <i>For C2 tyres</i> SRTT16C | |
| $S_{\text{Nominal}} = \text{Tyre nominal section width}$ | |

Paragraph 2.1.2.1., amend to read:

"2.1.2.1. ...

P_r = Inflation pressure corresponding to the the indication of the inflation pressure marked on the sidewall as required by paragraph 4.1. of this Regulation...."

Paragraph 2.1.2.12., amend to read:

"2.1.2.12. ...

Analogue signals should be filtered to remove noise. ..."

Paragraph 2.1.2.13., amend to read:

"2.1.2.13. ...

For the reference tyre:

If the coefficient of variation of the peak braking coefficient CV_{μ} of the reference tyre, which is calculated by the formula given in 4.2.8.2. of part (A) of this Annex, is higher than five per cent, discard all data and repeat the test for this reference tyre.

For the candidate tyres:

The coefficients of variation CV_{μ} are calculated for all the candidate tyres according to the formula in 4.2.8.2. of part (A) of this Annex. If one coefficient of variation is greater than five per cent, discard the data for this candidate tyre and repeat the test. ..."

Paragraph 2.2.2.3., amend to read:

"2.2.2.3. ...

P_r = Inflation pressure corresponding to the indication of the inflation pressure marked on the sidewall as required by paragraph 4.1. of this Regulation.

...

P_r = Inflation pressure corresponding to the indication of the inflation pressure marked on the sidewall as required by paragraph 4.1. of this Regulation.

Check the tyre pressure just prior to testing at ambient temperature."

Paragraph 2.2.2.8.1., amend to read:

"2.2.2.8.1. ...

All conditions are in conformity with paragraphs 2.2.1. to 2.2.2.5. above."

Annex 5 – Appendix, Example 1, amend to read:

"...

| No. | 1 | 2 | 3 | 4 | 5 | 6 | 7 | 8 | 9 | 10 |
|--|---|---|---|---|---|---|---|---|---|----|
| Size | | | | | | | | | | |
| Service description | | | | | | | | | | |
| Reference (test) inflation pressure ⁽¹⁾ (kPa) | | | | | | | | | | |
| Tyre identification | | | | | | | | | | |
| ... | | | | | | | | | | |
| Wet Grip Index | | | | | | | | | | |
| Surface temp. (°C) | | | | | | | | | | |
| ... | | | | | | | | | | |

...

⁽¹⁾ for C2 and C3 tyres, corresponding to the indication of the inflation pressure marked on the sidewall as required by paragraph 4.1. of this Regulation"

Annex 5 – Appendix, Example 2, amend to read:

"...

| No. | 1 | 2 | 3 | 4 | 5 |
|--|-----------------------|------------|---------------------|------------|-----------------------|
| Brand name | Uniroyal | TYRE B | TYRE C | TYRE D | Uniroyal |
| Pattern/Trade description | ASTM F 2493 SRTT16 | PATTERN B | PATTERN C | PATTERN D | ASTM F 2493 SRTT16 |
| Size | P225/60R16 | SIZE B | SIZE C | SIZE D | P225/60R16 |
| Service description | 97S | LI/SS | LI/SS | LI/SS | 97S |
| Reference (test) inflation pressure ⁽¹⁾ (kPa) | | | | | |
| Tyre identification | XXXXXXXXXX | YYYYYYYYYY | ZZZZZZZZ | NNNNNNNNNN | XXXXXXXXXX |

...

⁽¹⁾ for C2 and C3 tyres, corresponding to the indication of the inflation pressure marked on the sidewall as required by paragraph 4.1. of this Regulation"

Annex 6

Paragraph 2.2., amend to read:

"2.2. Measuring rim

The tyre shall be mounted on a steel or light alloy measuring rim, as follows:

- (a) For Class C1 tyres, the width of the rim shall be as defined in ISO 4000-1:2015,
- (b) For Class C2 and C3 tyres, the width of the rim shall be as defined in ISO 4209 1:2001.

In cases where the width is not defined in the above mentioned ISO Standards, the rim width as defined by one of the standards organizations as specified in Appendix 4 may be used."

Paragraph 2.4.3. shall be deleted.

Paragraph 3.1., amend to read:

"3.1. General

The test consists of a measurement of rolling resistance in which the tyre is inflated to the required cold inflation pressure and the inflation pressure allowed to build up, i.e., "capped inflation".

Paragraph 3.2, amend to read:

"3.2. Test speeds

The rolling resistance coefficient value shall be obtained at the appropriate drum speed specified in Table 1."

Table 1, amend to read:

"Table 1

Test Speeds (in km/h)

| <i>Tyre Class</i> | <i>C1</i> | <i>C2 and C3</i> | <i>C3</i> | |
|-------------------|-----------|------------------|------------------------|-------------------------|
| Load index | All | LI ≤ 121 | LI > 121 | |
| Speed symbol | All | All | J (100 km/h) and lower | K (110 km/h) and higher |
| Test speed (km/h) | 80 | 80 | 60 | 80 |

"

Table 2, amend to read:

"Table 2

Test loads and inflation pressures

| <i>Tyre Class</i> | <i>C1</i> | | <i>C2, C3</i> |
|--|----------------------|---------------------------------|--|
| | <i>Standard load</i> | <i>Reinforced or extra load</i> | |
| Load % of maximum load capacity as indicated by the load capacity index | 80 | 80 | 85 (refer to single application) |
| Inflation pressure kPa | 210 | 250 | Test inflation pressure corresponding to the indication of the inflation pressure marked on the sidewall as required by paragraph 4.1. of this Regulation. |

Note: The inflation pressure shall be capped with the accuracy specified in paragraph 4. of Appendix 1 to this annex.

"

Paragraph 4.6.2., amend to read:

"4.6.2. Deceleration method

The deceleration method follows the procedure below:

- (a) Remove the tyre from the test surface while running at a speed greater than test speed;
- (b) Record the deceleration of the test drum $\Delta\omega_{D0}/\Delta t$ and that of the unloaded tyre $\Delta\omega_{T0}/\Delta t$ or record the deceleration of the test drum j_{D0} and

that of the unloaded tyre j_{T0} in exact or approximate form in accordance with paragraph 3.5. above.

The speed range for measurement includes the test speed and does not exceed 10 km/h above and 10 km/h below the test speed."

Paragraph 5.1.5., amend to read:

"5.1.5. Deceleration method

Calculate the parasitic losses F_{pl} , in newton.

$$F_{pl} = \frac{I_D}{R} \left(\frac{\Delta\omega_{D0}}{\Delta t_0} \right) + \frac{I_T}{R_r} \left(\frac{\Delta\omega_{T0}}{\Delta t_0} \right)$$

where: ...

$\Delta\omega_{D0}$ is the test drum angular speed increment, drum without tyre, in radians per second,

$\Delta\omega_{T0}$ is the tyre angular speed increment, unloaded tyre, in radian per second. ..."

Paragraph 5.2.1., amend to read:

"5.2.1. General

The rolling resistance F_r , expressed in newton, is calculated using the values obtained by testing the tyre to the conditions specified in this Regulation and by subtracting the appropriate parasitic losses F_{pl} , obtained according to paragraph 5.1. above."

Paragraph 6.4., amend to read:

"6.4. Measurement result

Where n measurements are greater than 1, if required by paragraph 4.6. above, the measurement result shall be the average of the C_r values obtained for the n measurements, after the corrections described in paragraphs 6.2. and 6.3. above have been made. Following this method, final C_r results shall be expressed in N/kN and rounded to the first decimal place according to ISO 80000-1:2009, B.3, rule B."

Annex 6 - Appendix 1

Paragraph 1., amend to read:

"1. Purpose

The limits specified in this appendix are necessary, but may not be sufficient, in order to achieve suitable levels of repeatable test results, which can also be correlated among various test laboratories."

"2.2. Run-out

In case vehicle rims are used, the run-out shall meet the following criteria:

(i) for C1 tyres, C2 tyres and for C3 tyres with $LI \leq 121$:

- (a) Maximum radial run-out: 0.5 mm,
- (b) Maximum lateral run-out: 0.5 mm;

(ii) for C3 tyres with $LI \geq 122$:

- (a) Maximum radial run-out: 2.0 mm,
- (b) Maximum lateral run-out: 2.0 mm."

Paragraph 3.1., amend to read:

- "3.1. Load application
- The direction of tyre loading application shall be kept normal to the test surface and shall pass through the wheel centre within:
- (a) 1 mrad for the force method;
 - (b) 5 mrad for the torque, power and deceleration methods."

Paragraph 4.(a), amend to read:

- "(a) Tyre loading:
- (i) For C1 tyres, C2 tyres and for C3 tyres with $LI \leq 121$: ± 20 N or ± 0.5 per cent, whichever is greater;
 - (ii) For C3 tyres with $LI \geq 122$: ± 45 N or ± 0.5 per cent whichever is greater;"

Paragraph 5., amend to read:

"...

| Parameter | C1 tyres, C2 tyres and C3 tyres with $LI \leq 121$ | C3 tyres with $LI \geq 122$ |
|-----------|--|--|
| Tyre load | ± 10 N or ± 0.5 % ^(a) | ± 30 N or ± 0.5 % ^(a) |

..."

Paragraph 7., amend to read:

- "7. Test surface roughness
- The roughness, measured laterally, of the new smooth steel drum surface shall have a maximum centreline average height value of 6.3 μm . This value should be reconfirmed in case visible damage should occur. ..."

Annex 6 - Appendix 2, amend to read:

"Annex 6 - Appendix 2

(omitted)"

Annex 6 - Appendix 3, amend to read and add a footnote (1):

"...

Part1: Report

...

2. Name and address of manufacturer:

...

4. Brand name and trade description:

...

6. Category of use:

6.1. Tyre for use in severe snow conditions (Yes/No)².....

Part 2: Test data

...

3.3. Reference (test) inflation pressure⁽¹⁾: kPa

⁽¹⁾ for C2 and C3 tyres, corresponding to the indication of the inflation pressure marked on the sidewall as required by paragraph 4.1. of this Regulation as indicated on the sidewall. "

Annex 7

Paragraph 3.4.1.1., amend to read:

"3.4.1.1. For each tyre and each braking test, the arithmetic mean \bar{a} and corrected sample standard deviation σ_a of the mfdd shall be computed and reported.

The coefficient of variation CV_a of a tyre braking test shall be computed as:

$$CV_a = 100\% \cdot \frac{\sigma_a}{\bar{a}}$$

with

$$\sigma_a = \sqrt{\frac{1}{N-1} \sum_{i=1}^N (a_i - \bar{a})^2}$$

"

Paragraph 3.4.1.2., amend to read:

"3.4.1.2 Weighted averages wa_{SRTT} of two successive tests of the SRTT shall be computed taking into account the number of candidate tyres in between:

In the case of the order of testing R1 – T – R2, the weighted average of the SRTT to be used in the comparison of the performance of the candidate tyre shall be taken to be:

$$wa_{SRTT} = \frac{1}{2}(\overline{a_{R1}} + \overline{a_{R2}})$$

Where:

$\overline{a_{Rn}}$ is the arithmetic mean of the mfdd for the n-th test of the SRTT.

In the case of the order of testing R1 – T1 – T2 – R2, the weighted averages wa_{SRTT} of the SRTT to be used in the comparison of the performance of the candidate tyre shall be taken to be:

$$wa_{SRTT} = \frac{2}{3}\overline{a_{R1}} + \frac{1}{3}\overline{a_{R2}} \quad \text{for comparison with the candidate tyre T1 and}$$

$$wa_{SRTT} = \frac{1}{3}\overline{a_{R1}} + \frac{2}{3}\overline{a_{R2}} \quad \text{for comparison with the candidate tyre T2. "}$$

Paragraph 3.4.1.3., amend to read:

"3.4.1.3. The snow grip index (SG) of a candidate tyre Tn shall be computed as the quotient of the arithmetic mean $\overline{a_{Tn}}$ of the mfdd of the tyre Tn and the applicable weighted average wa_{SRTT} of the SRTT:

$$SG(Tn) = \frac{\overline{a_{Tn}}}{wa_{SRTT}}$$

"

Paragraph 3.4.2., amend to read:

"3.4.2. Statistical validations

The sets of repeats of measured or computed mfdd for each tyre should be examined for normality, drift, eventual outliers.

The consistency of the arithmetic means \bar{a} and corrected sample standard deviations σ_a of successive braking tests of SRTT should be examined.

In addition and in order to take in account possible test evolution, the coefficient of validation $CVal_a(SRTT)$ is calculated on the basis of the average values of any two consecutive groups of the minimum 6 runs of the Standard Reference Test Tyre according to

$$CVal_a(SRTT) = 100\% \times \left| \frac{\overline{a_{R2}} - \overline{a_{R1}}}{\overline{a_{R1}}} \right|$$

The coefficient of validation $CVal_a(SRTT)$ shall not differ by more than 5 per cent.

The coefficient of variation CV_a , as defined in paragraph 3.1.1. of this annex, of any braking test shall be less than 6 per cent.

If those conditions are not met, tests shall be performed again after re-grooming the test course."

Paragraph 4.1., amend to read:

"4.1. (omitted)"

Paragraph 4.2., amend to read:

"4.2. Methods for measuring snow grip index

Snow performance is based on a test method by which the average acceleration in an acceleration test, of a candidate tyre is compared to that of a standard reference tyre.

The relative performance shall be indicated by a snow grip index (SG).

When tested in accordance with the acceleration test in paragraph 4.7. below, the average acceleration of a candidate snow tyre shall be at least 1.25 compared to one of the two equivalent Standard Reference Test Tyres SRTT19.5 and SRTT22.5."

Paragraph 4.7., amend to read:

"4.7. Acceleration on snow test procedure for snow grip index of Class C3"

Paragraph 4.7.5.4., amend to read:

"4.7.5.4. For every candidate tyre and the standard reference tyre, the acceleration test runs shall be repeated a minimum of 6 times and the coefficients of variation CV_{AA} shall be lower than or equal to 6 per cent. CV_{AA} shall be calculated for minimum 6 valid runs according to

$$CV_{AA} = 100\% \cdot \frac{\sigma_{AA}}{\overline{AA}}$$

where

$\sigma_{AA} = \sqrt{\frac{1}{N-1} \sum_{i=1}^N (AA_i - \overline{AA})^2}$ denotes the corrected sample standard deviation and

\overline{AA} the arithmetic mean of the Average Accelerations (AA_i) of N test runs."

Paragraph 4.8.1., amend to read:

"4.8.1. Calculation of the average acceleration AA

Each time the measurement is repeated, the average acceleration AA ($m \cdot s^{-2}$) is calculated by

$$AA = \frac{S_f^2 - S_i^2}{2D}$$

Where D (m) is the distance covered between the initial speed S_i ($m \cdot s^{-1}$) and the final speed S_f ($m \cdot s^{-1}$)."

Paragraphs 4.8.2. and 4.8.3., amend to read:

"4.8.2. Validation of results

For the candidate tyres:

The coefficient of variation CV_{AA} of the average acceleration is calculated according to the formula in 4.7.5.4. of this Annex for all the candidate tyres. If one coefficient of variation is greater than 6 per cent, discard the data for this candidate tyre and repeat the test.

For the reference tyre:

If the coefficient of variation CV_{AA} of the average acceleration calculated according to the formula in 4.7.5.4. of this Annex for each group of min 6 runs of the reference tyre is higher than 6 per cent, discard all data and repeat the test for all tyres (the candidate tyres and the reference tyre).

In addition and in order to take in account possible test evolution, the coefficient of validation $CVal_{AA}(SRTT)$ is calculated on the basis of the average values of any two consecutive groups of minimum 6 runs of the reference tyre according to

$$CVal_{AA}(SRTT) = 100\% \times \left| \frac{\overline{AA_2} - \overline{AA_1}}{\overline{AA_1}} \right|$$

If the coefficient of validation is greater than 6 per cent, discard the data for all the candidate tyres and repeat the test.

4.8.3. Calculation of the weighted averages

Weighted averages wa_{SRTT} of the average accelerations of two successive tests of the SRTT are calculated according to Table 1:

Table 1

| <i>If the number of sets of candidate tyres between two successive runs of the reference tyre is:</i> | <i>and the set of candidate tyres to be qualified is:</i> | <i>then wa_{SRTT} is calculated by applying the following:</i> |
|---|---|--|
| 1 R – T1 – R | T1 | $wa_{SRTT} = \frac{1}{2}(\overline{AA_{R1}} + \overline{AA_{R2}})$ |
| 2 R – T1 – T2 – R | T1 T2 | $wa_{SRTT} = \frac{2}{3}\overline{AA_{R1}} + \frac{1}{3}\overline{AA_{R2}}$ $wa_{SRTT} = \frac{1}{3}\overline{AA_{R1}} + \frac{2}{3}\overline{AA_{R2}}$ |
| 3 R – T1 – T2 – T3 – R | T1 T2 T3 | $wa_{SRTT} = \frac{3}{4}\overline{AA_{R1}} + \frac{1}{4}\overline{AA_{R2}}$ $wa_{SRTT} = \frac{1}{2}(\overline{AA_{R1}} + \overline{AA_{R2}})$ $wa_{SRTT} = \frac{1}{4}\overline{AA_{R1}} + \frac{3}{4}\overline{AA_{R2}}$ |

where $\overline{AA_{Rn}}$ is the arithmetic mean of the average accelerations in the n-th test of the Standard Reference Test Tyre."

Paragraph 4.8.4., shall be deleted.

Paragraph 4.8.5., renumber as 4.8.4. and amend to read:

"4.8.4. Calculation of the relative snow grip index of the tyre

The snow grip index represents the relative performance of the candidate tyre compared to the reference tyre.

$$SG(T_n) = \frac{\overline{AA}_{T_n}}{wa_{SRTT}}$$

where \overline{AA}_{T_n} is the arithmetic mean of the average accelerations of the n-th candidate tyre"

Paragraph 4.8.6., renumber as 4.8.5.

Annex 7 - Appendix 2, amend to read:

"...

Part 1 - Report

...

2. Name and address of manufacturer:

...

4. Brand name and trade description:

...

7. Snow grip index relative to SRTT according to paragraph 6.4.1.1.

...

Part 2 - Test data

...

4. Test tyre details and data:

| | <i>SRTT</i> (1st test) | <i>Candidate 1</i> | <i>Candidate 2</i> | <i>SRTT</i> (2nd test) |
|--|------------------------|--------------------|--------------------|------------------------|
| Brand name | | | | |
| Trade description/ commercial name | | | | |
| Tyre size designation | | | | |
| Service description | | | | |
| Test rim width code | | | | |
| Reference (test) inflation pressure ⁽¹⁾ (kPa) | | | | |
| Tyre loads F/R (kg) | | | | |
| Tyre loads F/R (% of load associated to LI ⁽²⁾) | | | | |
| Tyre pressure F/R (kPa) | | | | |

5. Test results: mean fully developed decelerations ($m \cdot s^{-2}$) / traction coefficient⁽³⁾

| <i>Run number</i> | <i>Specification</i> | <i>SRTT</i> (1st test) | <i>Candidate 1</i> | <i>Candidate 2</i> | <i>SRTT</i> (2nd test) |
|-------------------|----------------------|------------------------|--------------------|--------------------|------------------------|
| 1 | | | | | |
| 2 | | | | | |
| 3 | | | | | |

| Run number | Specification | SRTT <small>(1st test)</small> | Candidate 1 | Candidate 2 | SRTT <small>(2nd test)</small> |
|---------------------------|---------------------------|--------------------------------|-------------|-------------|--------------------------------|
| 4 | | | | | |
| 5 | | | | | |
| 6 | | | | | |
| | | | | | |
| | | | | | |
| | | | | | |
| Mean | | | | | |
| Standard deviation | | | | | |
| Coefficient of variation | $CV_a \leq 6\%$ | | | | |
| Coefficient of Validation | $CV_{val}(SRTT) \leq 5\%$ | X | X | X | |
| SRTT weighted average | | X | | | X |
| Snow grip index | | 1.00 | | | X |

"

Annex 7 - Appendix 2, add new footnotes (1) and (2) and renumber the former footnote (1) to (3):

- "⁽¹⁾ for C2 tyres, corresponding to the indication of the inflation pressure marked on the sidewall as required by paragraph 4.1. of this Regulation
- ⁽²⁾ for C2 tyres, refer to single load
- ⁽³⁾ Strike out what does not apply."

Annex 7 - Appendix 3, amend to read:

"...

Part 1 - Report

...

2. Name and address of manufacturer:

...

4. Brand name and trade description:

...

Part 2 - Test data

...

4. Test tyre details and data:

| | SRTT <small>(1st test)</small> | Candidate 1 | Candidate 2 | Candidate 3 | SRTT <small>(2nd test)</small> |
|---------------------------------------|--------------------------------|-------------|-------------|-------------|--------------------------------|
| Brand name | | | | | |
| Trade description/ commercial name | | | | | |
| Tyre size designation | | | | | |
| Service description | | | | | |

| | | | | | |
|---|--|--|--|--|--|
| Test rim width code | | | | | |
| Reference (test) inflation pressure ⁽¹⁾ (kPa) | | | | | |
| Tyre loads F/R (kg) | | | | | |
| Tyre loads F/R (% of load associated to LI ⁽²⁾) | | | | | |
| Tyre pressure F/R (kPa) | | | | | |

5. Test results: average accelerations ($m \cdot s^{-2}$)

| Run number | Specification | SRTT (1st test) | Candidate 1 | Candidate 2 | Candidate 3 | SRTT (2nd test) |
|---------------------------|-----------------------------|--------------------|-------------|-------------|-------------|-----------------|
| 1 | | | | | | |
| 2 | | | | | | |
| 3 | | | | | | |
| 4 | | | | | | |
| 5 | | | | | | |
| 6 | | | | | | |
| | | | | | | |
| | | | | | | |
| | | | | | | |
| Mean | | | | | | |
| Standard deviation | | | | | | |
| Slip ratio (per cent) | | | | | | |
| Coefficient of variation | $CV_{AA} \leq 6 \%$ | | | | | |
| Coefficient of Validation | $CVal_{AA}(SRTT) \leq 6 \%$ | | | | | |
| SRTT weighted average | | | | | | |
| Snow grip index | | 1.00 | | | | |

..."

Annex 7 - Appendix 3, add new footnotes (1) and (2):

"⁽¹⁾ corresponding to the indication of the inflation pressure marked on the sidewall as required by paragraph 4.1. of this Regulation

"⁽²⁾ refer to single load"

2 February 2021

Agreement

Concerning the Adoption of Harmonized Technical United Nations Regulations for Wheeled Vehicles, Equipment and Parts which can be Fitted and/or be Used on Wheeled Vehicles and the Conditions for Reciprocal Recognition of Approvals Granted on the Basis of these United Nations Regulations*

(Revision 3, including the amendments which entered into force on 14 September 2017)

Addendum 116 – UN Regulation No. 117

Revision 4 - Amendment 4

Supplement 12 to the 02 series of amendments – Date of entry into force: 3 January 2021

Uniform provisions concerning the approval of tyres with regard to rolling sound emissions and/or to adhesion on wet surfaces and/or to rolling resistance

This document is meant purely as documentation tool. The authentic and legal binding text is: ECE/TRANS/WP.29/2020/75.



UNITED NATIONS

* Former titles of the Agreement:

Agreement concerning the Adoption of Uniform Conditions of Approval and Reciprocal Recognition of Approval for Motor Vehicle Equipment and Parts, done at Geneva on 20 March 1958 (original version); Agreement concerning the Adoption of Uniform Technical Prescriptions for Wheeled Vehicles, Equipment and Parts which can be Fitted and/or be Used on Wheeled Vehicles and the Conditions for Reciprocal Recognition of Approvals Granted on the Basis of these Prescriptions, done at Geneva on 5 October 1995 (Revision 2).



Annex 3

Paragraph 2.5.1., amend to read:

"2.5.1. General

Four identical tyres shall be fitted on the test vehicle. In the case of C3 tyres with a load capacity index in excess of 121 and without any dual fitting indication, two of these tyres of the same type and range shall be fitted to the rear axle of the test vehicle; the front axle shall be fitted with tyres of size suitable for the axle load and planed down to the minimum depth in order to minimize the influence of tyre/road contact noise while maintaining a sufficient level of safety.

In the case of C2 tyres with a load capacity index lower or equal to 121, with a section width wider than 200 mm, an aspect ratio lower than 55, a rim diameter code lower than 15 and without any dual fitting indication, two of these tyres of the same type and range shall be fitted to the rear axle of the test vehicle; the front axle shall be fitted with tyres of a size suitable for the axle load and planed down to the minimum depth in order to minimize the influence of tyre/road contact noise while maintaining a sufficient level of safety.

Tyres with special fitting requirements shall be tested in accordance with these requirements (e.g. rotation direction). The tyres shall have full tread depth before being run-in.

Tyres are to be tested on rims permitted by the tyre manufacturer."

10 December 2021

Agreement

Concerning the Adoption of Harmonized Technical United Nations Regulations for Wheeled Vehicles, Equipment and Parts which can be Fitted and/or be Used on Wheeled Vehicles and the Conditions for Reciprocal Recognition of Approvals Granted on the Basis of these United Nations Regulations*

(Revision 3, including the amendments which entered into force on 14 September 2017)

Addendum 116 – UN Regulation No. 117

Revision 4 - Amendment 5

Supplement 13 to the 02 series of amendments – Date of entry into force: 30 September 2021

Uniform provisions concerning the approval of tyres with regard to rolling sound emissions and/or to adhesion on wet surfaces and/or to rolling resistance

This document is meant purely as documentation tool. The authentic and legal binding text is: ECE/TRANS/WP.29/2021/8 (as amended by paragraph 78 of the report ECE/TRANS/WP.29/1157).



UNITED NATIONS

* Former titles of the Agreement:

Agreement concerning the Adoption of Uniform Conditions of Approval and Reciprocal Recognition of Approval for Motor Vehicle Equipment and Parts, done at Geneva on 20 March 1958 (original version); Agreement concerning the Adoption of Uniform Technical Prescriptions for Wheeled Vehicles, Equipment and Parts which can be Fitted and/or be Used on Wheeled Vehicles and the Conditions for Reciprocal Recognition of Approvals Granted on the Basis of these Prescriptions, done at Geneva on 5 October 1995 (Revision 2).



Paragraph 2.18., amend to read:

- "2.18. *"Standard Reference Test Tyre"* or *"SRTT"* means a tyre that is produced, controlled and stored in accordance with the standards of ASTM International:
- (a) E1136 – 17 for the size P195/75R14 and referred to as "SRTT14",
 - (b) F2872 – 16 for the size 225/75R16C and referred to as "SRTT16C",
 - (c) F2871 – 16 for the size 245/70R19.5 and referred to as "SRTT19.5",
 - (d) F2870 – 16 for the size 315/70R22.5 and referred to as "SRTT22.5",
 - (e) F2493 – 19 for the size P225/60R16 and referred to as "SRTT16".

Paragraph 2.19.3., amend to read:

- "2.19.3. *"Control tyre"* means a normal production tyre that is used to establish the wet grip or snow grip performance of tyre sizes unable to be fitted to the same vehicle as the standard reference test tyre — see paragraph 2.2.2.8. of Annex 5, part (B) and paragraph 3.4.3. of Annex 7 to this Regulation."

Paragraph 2.19.4., amend to read:

- "2.19.4. *"Wet grip index"* (*G*) means the wet grip performance of a candidate tyre relative to that of the applicable standard reference test tyre."

Paragraph 2.19.5., amend to read:

- "2.19.5. *"Snow grip index ("SG")"* means the snow grip performance of a candidate tyre relative to the performance of the applicable SRTT."

Insert a new paragraph 4.3.1. to read:

- "4.3.1. In case the approval of a tyre pursuant to this Regulation has been granted by the same Type Approval Authority than that granting the approval pursuant to UN Regulation No. 30 or UN Regulation No. 54, the approval mark pursuant to UN Regulation No. 30 or UN Regulation No. 54 can be combined with an indication of the applicable series of amendments to which the tyre was approved pursuant to UN Regulation No. 117 on the form of 2 digits (example "02" indicating that the UN Regulation No.117 approval was granted following the 02 series of amendments) and the suffixes according to paragraph 5.2.2. using the addition sign "+", as described in Annex 2, Appendix 3 of this Regulation, for example "0236378 + 02S1WR2"."

Paragraph 4.4., amend to read:

- "4.4. The markings referred to in paragraph 4.2. and the approval mark prescribed in paragraph 5.4. of this Regulation shall be clearly legible, indelible and raised above or sunk below the tyre surface."

Paragraph 4.4.1., amend to read:

- "4.4.1. The approval mark shall be situated in the lower area of the tyre on at least one of its sidewalls. However, in the case of tyres identified by the "tyre to rim fitment configuration" symbol "A" or "U", the markings may be located anywhere on the outside sidewall of the tyre."

Paragraph 5.4.4., amend to read:

- "5.4.4. The marking on the tyre sidewalls of suffix(es) to the approval number removes the requirement for any additional marking on the tyre of the specific type approval number for conformity to the Regulation(s) to which the suffix refers as per paragraph 5.2.2. above."

Paragraph 6.4.1.1., amend to read:

- "6.4.1.1. Class C1, C2 and C3 tyres

The minimum snow grip index value, as calculated in the procedure described in Annex 7 and compared with the respective Standard Reference Test Tyre (SRTT) shall be as follows:

| Class of tyre | Snow grip index (brake on snow method) ^(a) | | Snow grip index (spin traction method) ^(b) | Snow grip index (acceleration method) ^(c) |
|---------------|---|----------------|---|--|
| | Ref.s = SRTT14, SRTT16 | Ref. = SRTT16C | Ref.s = SRTT14, SRTT16 | Ref.s = SRTT19.5, SRTT22.5 |
| C1 | 1.07 | No | 1.10 | No |
| C2 | No | 1.02 | 1.10 | No |
| C3 | No | No | No | 1.25 |

^(a) See paragraph 3. of Annex 7 to this Regulation

^(b) See paragraph 2. of Annex 7 to this Regulation

^(c) See paragraph 4. of Annex 7 to this Regulation "

Paragraphs 7.1.3. and 7.1.4., renumber as 7.2. and 7.3.

Insert new paragraphs 12.10. to 12.12. to read:

"12.10. Until 3 months after the date of entry into force of Supplement 13 to the 02 series of amendments to this Regulation, Contracting Parties applying this Regulation can continue to grant type approvals according to the 02 series of amendments to this Regulation, without taking into account the provisions of Supplement 13.

12.11. Until 1 September 2024, Contracting Parties applying this Regulation may continue to grant type approvals according to the 02 series of amendments to this Regulation, based on snow performance test described in Annex 7 to this Regulation using SRTT14 as reference tyre. ^(a)

12.12. Until 1 September 2024, Contracting Parties applying this Regulation may continue to grant type approvals according to the 02 series of amendments to this Regulation, based on the test procedures for measuring wet grip described in Annex 5 of this Regulation, without taking into account the provisions of Supplement 13."

Add a new footnote (a) to read:

" ^(a) SRTT14 will be available from the supplier until end of October 2021."

Annex 1

Item 8.4., amend to read:

"8.4. Snow grip level of the representative tyre size, see paragraph 2.7. of UN Regulation No. 117, as per item 7. of the test report in the appendix⁵ to Annex 7:..... (Snow grip index) using the brake on snow method,² spin traction method² or acceleration method.²"

Footnote 3, renumber to 5.

Item 16.1., amend to read:

"16.1. A list of documents in the approval file deposited at the Type Approval Authorities having delivered the approval and which can be obtained upon request.⁶"

Footnote 4, renumber to 6 and amend to read:

"⁶ In the case of "snow tyre for use in severe snow conditions" a test report according to Appendix 2 or Appendix 3, as applicable, to Annex 7 shall be submitted."

Annex 2

Appendix 3, amend to read:

"Combinations of markings of approvals issued in accordance with UN Regulations Nos. 117, 30 or 54"

Example 1

...

The above approval mark shows that the tyre concerned has been approved in the Netherlands (E 4) pursuant to UN Regulation No. 30 according to its 02 series of amendments (indicated by the first two digits of the approval number, "02") under approval number 0236378. It is also marked by "+ 02S1" which indicates that the tyre was also approved pursuant to UN Regulation No. 117 (02 series of amendments) for rolling sound at stage 1.

Example 2

[...]

The above approval mark shows that the tyre concerned has been approved in the Netherlands (E 4) pursuant to Regulation No. 30 according to its 02 series of amendments (indicated by the first two digits of the approval number, "02") under approval number 0236378. It is also marked by "+ 02S1WR2" which indicates that the tyre was also approved pursuant to Regulation No. 117 (02 series of amendments) for S1 (rolling sound at stage 1) W (wet adhesion) and R2 (rolling resistance at stage 2)."

Footnote 1, delete.

Annex 5

Title, amend to read:

"Test procedures for measuring the wet grip index of new tyres"

Part (A),

Paragraphs 1.1. and 1.2., delete.

Paragraph 1.3., renumber as 1.1.

Insert new paragraphs 2.2. and 2.3. to read:

"2.2. "Braking test" means a series of a specified number of test runs of the same test tyre (set) repeated within a short time frame.

2.3. "Test cycle" means a sequence of braking tests of the test tyres."

Paragraph 2.2., renumber as 2.4. and amend to read:

"2.4. "Test tyre" or "test tyre set" means a tyre or a tyre set whose wet grip braking performance is measured in a braking test."

Paragraph 2.3., renumber as 2.5. and amend to read:

"2.5. "Candidate tyre" or "candidate tyre set" means a tyre or a tyre set whose wet grip braking performance is evaluated relative to that of a reference tyre or reference tyre set."

Paragraph 2.4., renumber as 2.6. and amend to read:

"2.6. "Reference tyre" or "Reference tyre set" means a tyre or a tyre set of Standard Reference Test Tyres SRTT16."

Paragraph 2.5. (former), delete.

Paragraph 2.6., renumber as 2.7. and amend to read:

"2.7. "Braking force" means the longitudinal force, expressed in newtons, resulting from braking torque application."

Paragraph 2.7., renumber as 2.8. and amend to read:

"2.8. "Average Braking Force Coefficient" (BFC) means, for the vehicle method, the ratio of the average deceleration in a braking test to the acceleration due to gravity (rounded to $9.81 \text{ m}\cdot\text{s}^{-2}$)."

Insert a new paragraph 2.9. to read:

"2.9. "Dynamic braking force coefficient" ($\mu(t)$) means, for the trailer (or tyre test vehicle) method, the ratio of the braking force to the vertical load acquired in real time."

Paragraph 2.8., renumber as 2.10. and amend to read:

"2.10. "Peak braking force coefficient" (μ_{peak}) means, for the trailer (or tyre test vehicle) method, the maximum value of the dynamic braking force coefficient that occurs prior to lockup of the wheel as the braking torque is progressively increased."

Paragraph 2.9., renumber as 2.11.

Paragraph 2.10., renumber as 2.12. and amend to read:

"2.12. "Vertical load" means the normal force, expressed in newtons, exerted on the road resulting from the mass supported by the tyre."

Paragraph 2.11., renumber as 2.13.

Insert a new paragraph 2.14. to read:

"2.14. "Tyre set" means, for the trailer (or tyre test vehicle) method, one (1) tyre and, for the vehicle method, four (4) tyres."

Insert a new paragraph 2.15. to read:

"2.15. "Instrumented passenger car" means a commercialized passenger car equipped with an Antilock Braking System (ABS) and the measuring equipment listed in paragraph 4.1.2.2. of this Annex."

Paragraph 3.1.1., amend to read:

"3.1.1. The surface shall have a dense asphalt surface with a uniform gradient of not more than 2 per cent in both longitudinal and lateral directions and shall not deviate more than 6 mm when tested with a 3 m straight edge."

Paragraph 3.1.4., amend to read:

"3.1.4. The average macro texture depth as measured in accordance with ASTM E965-96 (Reapproved 2006) by a sand patch shall be 0.7 ± 0.3 mm. In case the vehicle method is used, the average macro texture depth shall be determined in both lanes where the tyres are going to brake."

Paragraph 3.1.5., amend to read:

- "3.1.5. The wetted frictional properties of the surface shall be measured using the Standard Reference Test Tyre SRTT16 either with the method described in paragraph 3.2.1. of this Annex in case the vehicle method (according to paragraph 4.1. below) is used, or with the method described in paragraph 3.2.2. in this Annex in case the trailer (or tyre test vehicle) method is used."

Paragraph 3.2.1., amend to read:

- "3.2.1. Using the procedure described in paragraph 4.1. of this Annex, perform two braking tests of the reference tyre, each consisting of at least six (6) valid test runs in the same direction on aligned segments of the track. The braking tests shall cover the entire potential braking area, including where the texture depth was measured.

Evaluate the braking tests as described in paragraphs 4.1.6.1. and 4.1.6.2. of this Annex. If the coefficient of variation of one braking test CV_{BFC} exceeds 4 per cent, dismiss the results and repeat the braking tests.

For each braking test, the arithmetic mean $\overline{BFC_{ave}}$ of the average Braking Force Coefficients shall be corrected for effects of temperature as follows:

$$BFC_{ave,corr} = \overline{BFC_{ave}} + a \cdot (\vartheta - \vartheta_0)$$

where

ϑ is the wetted surface temperature in degrees Celsius,

$$a = 0.002 \text{ } ^\circ\text{C}^{-1} \text{ and } \vartheta_0 = 20 \text{ } ^\circ\text{C} .$$

For each braking test, the temperature-corrected average Braking Force Coefficient ($BFC_{ave,corr}$) shall be not less than 0.57 and not greater than 0.79.

The arithmetic means of the temperature-corrected average Braking Force Coefficients of the two braking tests shall not differ by more than 10 per cent of the average of the two values:

$$CV_{al}(BFC_{ave,corr}) = 2 \cdot \left| \frac{BFC_{ave,corr,1} - BFC_{ave,corr,2}}{BFC_{ave,corr,1} + BFC_{ave,corr,2}} \right| \leq 10 \%$$

"

Paragraph 3.2.2., amend to read:

- "3.2.2. Using the procedure described in paragraph 4.2. of this Annex, perform in the same area where the average macro texture depth was measured one braking test of the reference tyre, consisting of at least six (6) valid test runs in the same direction.

Evaluate the braking test as described in paragraphs 4.2.8.1. and 4.2.8.2. of this Annex. If the coefficient of variation CV_μ exceeds 4 per cent, dismiss the results and repeat the braking test.

The arithmetic mean ($\overline{\mu_{peak}}$) of the measured peak braking force coefficients shall be corrected for effects of temperature as follows:

$$\mu_{peak,corr} = \overline{\mu_{peak}} + a \cdot (\vartheta - \vartheta_0)$$

where

ϑ is the wetted road surface temperature in degrees Celsius,

$$a = 0.002 \text{ } ^\circ\text{C}^{-1} \text{ and } \vartheta_0 = 20 \text{ } ^\circ\text{C} .$$

The temperature-corrected average peak braking force coefficient ($\mu_{peak,corr}$) shall be not less than 0.65 and not greater than 0.90."

Paragraph 3.3., amend to read:

"3.3. Atmospheric conditions

The wind conditions shall not interfere with wetting of the surface (wind-shields are allowed).

The wetted surface temperature and the ambient temperature shall be between:

| <i>Category of use</i> | <i>Wetted surface temperature</i> | <i>Ambient temperature</i> |
|------------------------|--|----------------------------|
| Normal tyres | 12 °C – 35 °C | 12 °C – 40 °C |
| Snow tyres | 5 °C – 35 °C | 5 °C – 40 °C |
| | Snow tyres for use in severe snow conditions | 5 °C – 20 °C |
| Special use tyres | not applicable | not applicable |

Moreover, the wetted surface temperature shall not vary during the test by more than 10 °C.

The ambient temperature shall remain close to the wetted surface temperature; the difference between the ambient and the wetted surface temperatures shall be less than 10 °C."

Paragraph 4.1.1., amend to read:

"4.1.1. Principle

The testing method covers a procedure for measuring the deceleration performance of C1 tyres during braking, using an instrumented passenger car.

Starting with a defined initial speed, the brakes are applied hard enough on four wheels at the same time to activate the ABS. The average deceleration is calculated between two pre-defined speeds."

Paragraph 4.1.2.1., amend to read:

"4.1.2.1. Vehicle

Any commercialized passenger car, preferably not older than 5 years, type approved pursuant to UN Regulation No. 13-H with regards to its braking system, which is fitted with an anti-lock system (ABS), shall be considered as suitable for the purpose of the test provided that the mechanical conditions of the passenger car meet the car manufacturer's recommendations and no warning from ABS (e.g. warning lights) is displayed.

Permitted modifications on the passenger car are as follows:

- (a) Those allowing the number of tyre sizes that can be mounted on the vehicle to be increased;
- (b) Those permitting automatic activation of the braking device to be installed;
- (c) Those permitting the vehicle to be guided or accelerated externally.

Any other modification of the vehicle and specifically of the braking system is prohibited."

Paragraph 4.1.2.2., amend to read:

"4.1.2.2. Measuring equipment

The exposed portions of the system shall tolerate 100 per cent relative humidity (rain or spray) and all other conditions, such as dust, shock and vibrations, which may be encountered in regular operation.

The vehicle shall be fitted with a sensor suitable for measuring speed on a wet surface and distance covered between two speeds.

To measure vehicle speed, a fifth wheel or non-contact precision (including e. g. radar, GPS, etc.) speed-measuring system shall be used.

The following tolerances shall be respected:

- (a) For speed measurement: $\pm 1 \%$ or ± 0.5 km/h, whichever is greater;
- (b) For distance: $\pm 1 \cdot 10^{-1}$ m."

Paragraph 4.1.3., amend to read:

"4.1.3. Conditioning of the test track and wetting condition

The test track surface shall be watered at least half an hour prior to testing in order to equalize the surface temperature and water temperature. External watering should be supplied continuously throughout testing. For the whole testing area, the water depth shall be (1.0 ± 0.5) mm, measured from the peak of the pavement.

The test track should then be conditioned by conducting at least ten test runs with tyres not involved in the test programme at 90 km/h."

Paragraph 4.1.4.1., amend to read:

"4.1.4.1. Tyre preparation and stabilization, rims and fitment on the vehicle

The test tyres shall be trimmed to remove all protuberances on the tread surface caused by mould air vents or flashes at mould junctions.

Fit the test tyres on rims specified by a recognized tyre and rim standards organization as listed in Appendix 4 to Annex 6 to this Regulation. Rim width code shall not differ by more than 0.5 from the measuring rim width code. Ensure proper bead seating by the use of a suitable lubricant. Excessive use of lubricant should be avoided to prevent slipping of the tyre on the wheel rim.

The tyres should be stabilized in performance prior to testing, which means that no evolution of the BFC value in test runs should be detectable; in any case there will be an ex-post verification according to paragraph 4.1.6.2. of this Annex. In all cases, tyre designed tread depth and designed tread block or rib integrity shall not change significantly with break-in, which means the pace and "severity" of the break-in needs to be carefully controlled to avoid such changes.

Place the fitted test tyres in a location such that they all have the same ambient temperature prior to testing and shield them from the sun to avoid excessive heating by solar radiation.

Maximum spacer (adapter) width allowed to mount tyres on the vehicle is 60 mm."

Paragraph 4.1.4.2., amend to read:

"4.1.4.2. Tyre load

The static load on each axle tyre shall lie between 60 per cent and 90 per cent of the tested tyre load capacity. Tyre loads on the same axle should not differ by more than 10 per cent.

It is prohibited to exceed the maximum axle load of the vehicle."

Paragraph 4.1.4.3., amend to read:

"4.1.4.3. Tyre inflation pressure

On the front axle, the inflation pressures p shall be calculated as follows:

$$p = p_{\text{ref}} \cdot \left(1.3 \cdot \frac{Q}{Q_{\text{ref}}} \right)^{1.25}$$

where

p_{ref} is the reference inflation pressure (250 kPa for standard-load and 290 kPa for extra-load versions, regardless of the reference pressure in the applicable standard);

Q is the average tyre vertical load on the front axle;

Q_{ref} is the reference vertical load associated with the load-capacity index.

On the rear axle, the inflation pressure shall be 220 kPa (for both standard-load and extra-load versions). The tyre pressure should be checked just prior to testing at ambient temperature and adjusted if required."

Paragraph 4.1.5.1.1., amend to read:

"4.1.5.1.1. The passenger car is driven in a straight line up to (85 ± 2) km/h."

Paragraph 4.1.5.1.2., amend to read:

"4.1.5.1.2. Once the passenger car has reached (85 ± 2) km/h, the brakes shall always be activated at the same place on the test track referred to as "braking starting point", with a longitudinal tolerance of 5 m and a transverse tolerance of 0.5 m. Braking tests shall occur on the same lanes and in the same direction that was used to examine the surface, including where the macro texture depth was measured, in accordance with paragraphs 3.1.4. and 3.1.5. above (with a transverse tolerance of 0.5 m)."

Paragraph 4.1.5.1.3.2., amend to read:

"4.1.5.1.3.2. The manual activation of the brakes depends on the type of transmission as follows. In both cases, the pedal effort shall be high enough to activate the ABS.

For manual transmission, as soon as the driver is in the measuring zone and having reached (85 ± 2) km/h, the driver should release the clutch and depress the brake pedal sharply, holding it down as long as necessary to perform the measurement.

For automatic transmission, as soon as the driver is in the measuring zone and having reached (85 ± 2) km/h, the driver should select neutral gear and then depress the brake pedal sharply, holding it down as long as necessary to perform the measurement.

For each braking test and for tyres not tested before, the first two runs shall be discarded."

Paragraph 4.1.5.1.4., amend to read:

"4.1.5.1.4. If any of the specifications listed above (including speed tolerance, longitudinal and transverse tolerance for the braking starting point, and braking time) are not met when a test run is made, the test run is invalidated and a new test run is made."

Paragraph 4.1.5.2., amend to read:

"4.1.5.2. Braking test and test cycle

Within the same test cycle, each test run of each braking test shall be made in the same direction and in accordance with paragraph 4.1.5.1. of this Annex. Several test cycles may be performed consecutively, where the final braking test of the reference tyre set of a test cycle may serve as the initial braking test of the reference test tyre set for the next test cycle.

Up to three different candidate tyre sets may be measured within the same test cycle according to the following procedure:"

Paragraph 4.1.5.2.1., amend to read:

"4.1.5.2.1. Initial braking test of the reference tyre (R_i): First, the reference tyre set is mounted on the instrumented passenger car and at least four (4) valid test runs shall be made."

Paragraph 4.1.5.2.2., amend to read:

"4.1.5.2.2. Braking test of a candidate tyre set (T_n): The reference tyre set is replaced by a candidate tyre set (T_n) and at least six (6) valid test runs of the candidate tyres shall be performed."

Paragraph 4.1.5.2.3., amend to read:

"4.1.5.2.3. After the braking test of the first candidate tyre set, up to two more candidate tyre sets may be measured."

Paragraph 4.1.5.2.4., amend to read:

"4.1.5.2.4. Final braking test of the reference tyres (R_f): The test cycle is closed by at least four (4) valid test runs of the same reference tyre set as at the beginning of the test cycle.

Examples:

(a) The run order for a test cycle of three candidate tyre sets (T₁ to T₃) would be the following:

$$R_i - T_1 - T_2 - T_3 - R_f$$

(b) The run order for a braking test (consisting of two test cycles) of five candidate tyre sets (T₁ to T₅) would be the following:

$$R_i - T_1 - T_2 - T_3 - R_f/R_i - T_4 - T_5 - R_f"$$

Paragraph 4.1.6.1., amend to read:

"4.1.6.1. Calculation of the average Braking Force Coefficient

For each valid test run *j*, the average Braking Force Coefficient $BFC_{ave,j}$ is calculated from the distance d_j covered between 80 km/h and 20 km/h as follows:

$$BFC_{ave,j} = \frac{v_i^2 - v_f^2}{2 \cdot d_j \cdot g}$$

where

v_f is the final speed in m/s; $v_f = 20 \text{ km/h} = 5.556 \text{ m/s}$

v_i is the initial speed in m/s; $v_i = 80 \text{ km/h} = 22.222 \text{ m/s}$

d_j is the distance covered in test run *j* between v_i and v_f in meters;

g is the acceleration due to gravity = $9.81 \text{ m}\cdot\text{s}^{-2}$."

Paragraph 4.1.6.2., amend to read:

"4.1.6.2. Validation of results

The coefficient of variation CV_{BFC} is calculated as follows:

$$CV_{BFC} = 100\% \cdot \frac{\sigma_{BFC}}{\overline{BFC_{ave}}}$$

where

$\sigma_{BFC} = \sqrt{\frac{1}{N-1} \sum_{j=1}^N (BFC_{ave,j} - \overline{BFC_{ave}})^2}$ denotes the corrected sample standard deviation and

$\overline{BFC_{ave}}$ the arithmetic mean of the average Braking Force Coefficients $BFC_{ave,j}$ of *N* test runs.

For the reference tyre:

- (a) The coefficient of variation CV_{BFC} of the initial and the final braking test of the reference tyre within one test cycle shall be less than or equal to 4 per cent.
- (b) The arithmetic means of the average Braking Force Coefficients of the initial and the final braking test shall not differ by more than 5 per cent of the average of the two values:

$$CV_{al}(BFC_{ave}) = 100\% \cdot 2 \cdot \frac{|\overline{BFC_{ave}}(R_i) - \overline{BFC_{ave}}(R_f)|}{\overline{BFC_{ave}}(R_i) + \overline{BFC_{ave}}(R_f)} \leq 5\%$$

where

$\overline{BFC_{ave}}(R_i) / \overline{BFC_{ave}}(R_f)$ is the arithmetic mean of the average Braking Force Coefficients in the initial/final braking test of the reference tyre within a test cycle.

- (c) The temperature-corrected average Braking Force Coefficients ($BFC_{ave,corr}$, see paragraph 3.2.1. of this Annex) as calculated from the initial and from the final braking tests of the reference tyre within a test cycle shall be not less than 0.57 and not greater than 0.79.

If one or more of the above conditions is not met, the complete test cycle shall be performed again.

For the candidate tyres (T):

The coefficient of variation CV_{BFC} is calculated for each candidate tyre set. If one coefficient of variation is higher than 4 per cent, the data shall be discarded and the braking test repeated for that candidate tyre set."

Paragraph 4.1.6.3., amend to read:

"4.1.6.3. Calculation of adjusted average Braking Force Coefficient

The average Braking Force Coefficient of the reference tyre set used for the calculation of its braking force coefficient is adjusted according to the positioning of each candidate tyre set in a given test cycle.

This adjusted average Braking Force Coefficient of the reference tyre $BFC_{adj}(R)$ is calculated in accordance with Table 1 where $\overline{BFC_{ave}}(R_i)$ is the arithmetic mean of the average Braking Force Coefficients in the initial braking test of the reference tyre set (R_i) and $\overline{BFC_{ave}}(R_f)$ is the arithmetic mean of the average Braking Force Coefficients in the final braking test of the same reference tyre set (R_f) within the test cycle.

Table 1

| <i>If the number and the sequence of candidate tyre sets within one test cycle is:</i> | <i>and the candidate tyre set to be qualified within this test cycle is:</i> | <i>the corresponding adjusted average Braking Force Coefficient of the reference tyre is calculated as follows:</i> |
|--|--|---|
| 1 $R_i - T_1 - R_f$ | T_1 | $BFC_{adj}(R) = 1/2 \cdot [\overline{BFC_{ave}}(R_i) + \overline{BFC_{ave}}(R_f)]$ |
| 2 $R_i - T_1 - T_2 - R_f$ | T_1 | $BFC_{adj}(R) = 2/3 \cdot \overline{BFC_{ave}}(R_i) + 1/3 \cdot \overline{BFC_{ave}}(R_f)$ |
| | T_2 | $BFC_{adj}(R) = 1/3 \cdot \overline{BFC_{ave}}(R_i) + 2/3 \cdot \overline{BFC_{ave}}(R_f)$ |
| 3 $R_i - T_1 - T_2 - T_3 - R_f$ | T_1 | $BFC_{adj}(R) = 3/4 \cdot \overline{BFC_{ave}}(R_i) + 1/4 \cdot \overline{BFC_{ave}}(R_f)$ |
| | T_2 | $BFC_{adj}(R) = 1/2 \cdot [\overline{BFC_{ave}}(R_i) + \overline{BFC_{ave}}(R_f)]$ |
| | T_3 | $BFC_{adj}(R) = 1/4 \cdot \overline{BFC_{ave}}(R_i) + 3/4 \cdot \overline{BFC_{ave}}(R_f)$ |

Paragraph 4.1.6.4., delete.

Paragraph 4.1.6.5., renumber as 4.1.6.4. and amend to read:

"4.1.6.4. Calculation of the wet grip index of the candidate tyre

The wet grip index $G(T_n)$ of the candidate tyre T_n ($n = 1, 2$ or 3) is calculated as follows:

$$G(T_n) = K_{\text{vehicle}} \cdot \{\overline{BFC}_{\text{ave}}(T_n) - [a \cdot \Delta BFC(R) + b \cdot \Delta\vartheta + c \cdot (\Delta\vartheta)^2 + d \cdot \Delta MTD]\}$$

where:

$\overline{BFC}_{\text{ave}}(T_n)$ is the arithmetic mean of the average Braking Force Coefficients of the candidate tyre T_n within a braking test;

$$\Delta BFC(R) = BFC_{\text{adj}}(R) - BFC(R_0)$$

$BFC_{\text{adj}}(R)$ is the adjusted average Braking Force Coefficient in accordance with Table 1;

$BFC(R_0) = 0.68$ is fixed as the Braking Force Coefficient for the reference tyre in the reference conditions;

$$\Delta\vartheta = \vartheta - \vartheta_0$$

ϑ is the measured wet surface temperature in degrees Celsius when the candidate tyre T_n is tested;

ϑ_0 is the wetted surface reference temperature for the candidate tyre according to its category of use as listed in Table 2;

$$\Delta MTD = MTD - MTD_0$$

MTD is the measured macro texture depth in mm of the track (see paragraph 3.1.4. of this Annex);

$MTD_0 = 0.8$ mm is the macro texture depth of the reference track;

$K_{\text{vehicle}} = 1.87$ is a factor to grant consistency between previous calculation of the wet grip index and this one, and to ensure convergence between vehicle and trailer method and

coefficients a , b , c and d are given in Table 2.

Table 2

| Category of use | ϑ_0 (°C) | a | b (°C ⁻¹) | c (°C ⁻²) | d (mm ⁻¹) |
|---|-----------------------|----------|----------------------------|----------------------------|----------------------------|
| Normal tyre | 20 | +0.99382 | +0.00269 | -0.00028 | -0.02472 |
| Snow tyre | 15 | +0.92654 | -0.00121 | -0.00007 | -0.04279 |
| Snow tyre for use in severe snow conditions | 10 | +0.72029 | -0.00539 | +0.00022 | -0.03037 |
| Special-use tyre | not defined | | | | |

Paragraph 4.1.7., amend to read:

"4.1.7. When a direct comparison between a candidate tyre and a reference tyre on the same vehicle is not possible the test method using a trailer or a tyre test vehicle (paragraph 4.2. of this Annex) shall be used."

Paragraphs 4.1.7.1. to 4.1.7.3., delete.

Paragraph 4.1.7.4. renumber as 3.4. and amend to read:

"3.4. Replacement of reference tyres

When irregular wear or damage results from tests, or when wear or aging influences the test results, the use of the reference tyre shall be discontinued."

Paragraph 4.2.2.1., amend to read:

"4.2.2.1. Tow vehicle and trailer or tyre test vehicle

The tow vehicle or the tyre test vehicle shall have the capability of maintaining the specified speed of (65 ± 2) km/h even under the maximum braking forces.

The trailer or the tyre test vehicle shall be equipped with one place where the tyre can be fitted for measurement purposes, hereinafter called "test position", and the following accessories:

- (a) Equipment to activate brakes in the test position;
- (b) A water tank to store sufficient water to supply the road surface wetting system, unless external watering is used;
- (c) Recording equipment to record signals from transducers installed at the test position and to monitor water application rate if the self-watering option is used.

In the case of the one axle trailer, in order to reduce "pitch disturbance", the longitudinal distance from the centre line of the articulation point of the coupling to the transverse centre line of the axle of the trailer shall be at least ten times the "hitch height" or the "coupling (hitch) height".

In order to reduce "lateral disturbance", the trailer or the tyre test vehicle should be technically designed to minimize lateral displacement during the application of maximum braking force. Visual lateral displacement should be avoided during braking manoeuvre.

The maximum variation of toe-settings and camber angle for the test position shall be within $\pm 0.5^\circ$ with maximum vertical load. Suspension arms and bushings shall have sufficient rigidity necessary to minimize free play and ensure compliance under application of maximum braking forces. The suspension system shall provide adequate load-carrying capacity and be of such a design as to isolate suspension resonance.

The test position shall be equipped with a typical or special automotive brake system which can apply sufficient braking torque to produce the maximum value of braking test wheel longitudinal force at the conditions specified.

The brake application system shall be able to control the time interval between initial brake application and peak longitudinal force as specified in paragraph 4.2.7.1. below.

The trailer or the tyre test vehicle shall be designed to accommodate the range of candidate tyre sizes to be tested.

The trailer or the tyre test vehicle shall have provisions for adjustment of vertical load as specified in paragraph 4.2.5.2. below."

Paragraph 4.2.2.2., amend to read:

"4.2.2.2. Measuring equipment

...

- (a) The minimum frequency response shall be flat from 0 Hz to 100 Hz within ± 1 per cent full scale;

..."

Paragraph 4.2.3., amend to read:

"4.2.3. Conditioning of the test track

The test track should be conditioned by conducting at least ten test runs with tyres not involved in the test program at (65 ± 2) km/h."

Paragraph 4.2.4., amend to read:

"4.2.4. Wetting conditions

The surface may be wetted from the track-side ("external watering") or by a wetting system incorporated in the test vehicle or the trailer ("self-watering").

4.2.4.1. If "external watering" is used, the test track surface shall be watered at least half an hour prior to testing in order to equalize the surface temperature and water temperature. External watering should be supplied continuously throughout testing. For the braking lanes used, the water depth shall be between 0.5 mm and 1.5 mm, measured from the peak of the pavement.

4.2.4.2. For "self-watering" systems, the tow vehicle and trailer or the tyre test vehicle is equipped with a pavement-wetting system, less the storage tank, which, in the case of the trailer, is mounted on the tow vehicle. The water being applied to the pavement ahead of the test tyres shall be supplied by a nozzle suitably designed to ensure that the water layer encountered by the test tyre has a uniform cross section at the test speed with a minimum splash and overspray.

The nozzle configuration and position shall ensure that the water jets are directed towards the test tyre and pointed towards the pavement at an angle of 20° to 30°.

The water shall strike the pavement 250 mm to 450 mm ahead of the centre of tyre contact. The nozzle shall be located 25 mm above the pavement or at the minimum height required to clear obstacles which the tester is expected to encounter, but in no case more than 100 mm above the pavement.

The water layer shall be at least 25 mm wider than the test tyre tread and applied so the tyre is centrally located between the edges. Water delivery rate shall ensure a water depth of (1.0 ± 0.5) mm and shall be consistent throughout the test to within ± 10 per cent. The volume of water per unit of wetted width shall be directly proportional to the test speed. The quantity of water applied at 65 km/h shall be 18 l/s per meter of width of wetted surface in case of a water depth of 1.0 mm."

Paragraph 4.2.5.1., amend to read:

"4.2.5.1. Tyre preparation and stabilization and rims

The test tyres shall be trimmed to remove all protuberances on the tread surface caused by mould air vents or flashes at mould junctions.

The test tyre shall be mounted on a rim specified by a recognized tyre and rim standards organization as listed in Appendix 4 to Annex 6 to this Regulation. The rim width code shall not differ by more than 0.5 from the measuring rim width code.

A proper bead seat should be achieved by the use of a suitable lubricant. Excessive use of lubricant should be avoided to prevent slipping of the tyre on the wheel rim.

The tyres should be stabilized in performance prior to testing, which means that no evolution of the μ_{peak} value in test runs should be detectable; in any case there will be an ex-post verification according to paragraph 4.2.8.2. of this Annex. In all cases, tyre designed tread depth and designed tread block or rib integrity shall not change significantly with break-in, which means the pace and "severity" of the break-in needs to be carefully controlled to avoid such changes.

The test tyres/rim assemblies shall be stored in a location for a minimum of two hours such that they all have the same ambient temperature prior to testing. They should be shielded from the sun to avoid excessive heating by solar radiation."

Paragraph 4.2.5.2., amend to read:

"4.2.5.2. Tyre load

The test load on the test tyre is (75 ± 5) per cent of the tyre load capacity."

Paragraph 4.2.6.1., amend to read:

"4.2.6.1. The test tyre set shall be installed on the measuring device and loaded to the specified test load according to paragraph 4.2.5.2. of this Annex.

For one-axle trailers, the hitch height and transverse position shall be adjusted in order to avoid any disturbance of the measuring results."

Paragraph 4.2.7.1.1., amend to read:

"4.2.7.1.1. The tow vehicle or the tyre test vehicle is driven onto the test track in a straight line at the specified test speed (65 ± 2) km/h."

Paragraph 4.2.7.1.3., amend to read:

"4.2.7.1.3. For self-watering system, water shall be delivered to the pavement ahead of the test tyre approximately 0.5 s prior to brake application."

Paragraph 4.2.7.1.4., amend to read:

"4.2.7.1.4. The brakes shall be activated within an area of six (6) meters in the longitudinal direction and 0.5 meters in the transversal direction of a measurement point of the wetted frictional properties of the surface and sand depth in accordance with paragraphs 3.1.4. and 3.1.5. above. The test shall be run in the same direction as in paragraph 3.2.2. of this Annex. The rate of braking application shall be such that the time interval between initial application of force and peak longitudinal force is in the range 0.2 s to 0.5 s."

Paragraph 4.2.7.2., amend to read:

"4.2.7.2. Test cycle

Within the same test cycle, each test run of each braking test shall be made in the same direction and in accordance with paragraph 4.2.7.1. of this Annex. Several test cycles may be performed consecutively, where the final braking test of the reference tyre set of a test cycle may serve as the initial braking test of the reference tyre set for the next test cycle.

Up to three candidate tyre sets may be measured within the same test cycle, provided that the tests are completed within one day."

Paragraph 4.2.7.2.1., amend to read:

"4.2.7.2.1. Initial braking test of the reference tyre set (R_i): first, the reference tyre set is mounted and at least six (6) valid test runs shall be made in accordance with paragraph 4.2.7.1. above."

Paragraph 4.2.7.2.2., amend to read:

"4.2.7.2.2. Braking test of a candidate tyre set (T_n): the reference tyre set is replaced by-a candidate tyre set and at least six (6) valid test runs with the candidate tyre set shall be performed."

Paragraph 4.2.7.2.3., amend to read:

"4.2.7.2.3. After the braking test of the first candidate tyre set, up to two more candidate tyre sets may be measured."

Paragraph 4.2.7.2.4., amend to read:

"4.2.7.2.4. Final braking test of the reference tyre set (R_f): the test cycle shall be closed by at least six (6) more valid test runs of the same reference tyre set as at the beginning of the test cycle.

Examples:

- (a) The run order for a test cycle with three candidate tyre sets (T₁ to T₃) would be the following:

$$R_i - T_1 - T_2 - T_3 - R_f$$

- (b) The run order for a braking test (consisting of two test cycles) of five candidate tyre sets (T₁ to T₅) would be the following:

$$R_i - T_1 - T_2 - T_3 - R_f / R_i - T_4 - T_5 - R_f "$$

Paragraph 4.2.8.1., amend to read:

"4.2.8.1. Calculation of the peak braking force coefficient

For each test run, the peak braking force coefficient (μ_{peak}) is the highest value of $\mu(t)$ before lockup occurs calculated as follows for each test run. Analogue signals should be filtered to remove noise. Digitally recorded signals must be filtered using a moving average technique.

$$\mu(t) = \left| \frac{f_h(t)}{f_v(t)} \right|$$

where:

$\mu(t)$ is the dynamic tyre braking force coefficient in real time;

$f_h(t)$ is the dynamic braking force in real time, in N;

$f_v(t)$ is the dynamic vertical load in real time, in N."

Paragraph 4.2.8.2., amend to read:

"4.2.8.2. Validation of results

The μ_{peak} coefficient of variation CV_{μ} is calculated as follows:

$$CV_{\mu} = 100\% \cdot \frac{\sigma_{\mu}}{\mu_{peak}}$$

where

$\sigma_{\mu} = \sqrt{\frac{1}{N-1} \sum_{j=1}^N (\mu_{peak,j} - \overline{\mu_{peak}})^2}$ denotes the corrected sample standard deviation and

$\overline{\mu_{peak}}$ the arithmetic mean of the peak braking force coefficients ($\mu_{peak,j}$) of N test runs.

For the reference tyre (R):

- (a) The coefficients of variation CV_{μ} of the initial and the final braking tests of the reference tyre within one test cycle shall be less than or equal to 4 per cent;
- (b) The arithmetic mean of the peak braking force coefficients of initial and the final braking test of the reference tyre within one test cycle shall not differ by more than 5 per cent of the average of the two values:

$$CV_{\mu}(\mu_{peak}) = 100\% \cdot 2 \cdot \left| \frac{\overline{\mu_{peak}}(R_i) - \overline{\mu_{peak}}(R_f)}{\overline{\mu_{peak}}(R_i) + \overline{\mu_{peak}}(R_f)} \right| \leq 5\%$$

where

$\overline{\mu_{peak}}(R_i) / \overline{\mu_{peak}}(R_f)$ is the arithmetic mean of the peak braking force coefficients in the initial/final braking test of the reference tyre within a test cycle;

- (c) The temperature-corrected average peak braking force coefficients ($\mu_{peak,corr}$, see paragraph 3.2.2. of this Annex) as calculated from the

initial and from the final braking test of the reference tyre within a test cycle shall be not less than 0.65 and not greater than 0.90.

If one or more of the above conditions is not met, the complete test cycle shall be performed again.

For the candidate tyre(s) (T_n):

The coefficient of variation of the peak braking force coefficient CV_μ is calculated for each candidate tyre. If one coefficient of variation is greater than 5 per cent, the data shall be discarded and the braking test repeated for this candidate tyre."

Paragraph 4.2.8.3., amend to read:

"4.2.8.3. Calculation of the adjusted average peak braking force coefficient of the reference tyre

The average peak braking force coefficient of the reference tyre used for the calculation of its braking force coefficient is adjusted according to the positioning of each candidate tyre in a given test cycle.

This adjusted average peak braking force coefficient of the reference tyre $\mu_{peak,adj}(R)$ is calculated in accordance with Table 3 where $\overline{\mu_{peak}}(R_i)$ is the arithmetic mean of the peak braking force coefficients in the initial test of the reference tyre (R_i) and $\overline{\mu_{peak}}(R_f)$ is the arithmetic mean of the peak-braking force coefficients in the final test of the same reference tyre (R_f) within one test cycle.

Table 3

| <i>If the number and the sequence of candidate tyre sets within one test cycle is:</i> | <i>and the candidate tyre set to be qualified within this test cycle is:</i> | <i>the corresponding adjusted peak braking force coefficients of the reference tyre is calculated as follows:</i> |
|--|--|---|
| 1 $R_i - T_1 - R_f$ | T_1 | $\mu_{peak,adj}(R) = 1/2 \cdot [\overline{\mu_{peak}}(R_i) + \overline{\mu_{peak}}(R_f)]$ |
| 2 $R_i - T_1 - T_2 - R_f$ | T_1 | $\mu_{peak,adj}(R) = 2/3 \cdot \overline{\mu_{peak}}(R_i) + 1/3 \cdot \overline{\mu_{peak}}(R_f)$ |
| | T_2 | $\mu_{peak,adj}(R) = 1/3 \cdot \overline{\mu_{peak}}(R_i) + 2/3 \cdot \overline{\mu_{peak}}(R_f)$ |
| 3 $R_i - T_1 - T_2 - T_3 - R_f$ | T_1 | $\mu_{peak,adj}(R) = 3/4 \cdot \overline{\mu_{peak}}(R_i) + 1/4 \cdot \overline{\mu_{peak}}(R_f)$ |
| | T_2 | $\mu_{peak,adj}(R) = 1/2 \cdot [\overline{\mu_{peak}}(R_i) + \overline{\mu_{peak}}(R_f)]$ |
| | T_3 | $\mu_{peak,adj}(R) = 1/4 \cdot \overline{\mu_{peak}}(R_i) + 3/4 \cdot \overline{\mu_{peak}}(R_f)$ |

Paragraph 4.2.8.4., delete.

Paragraph 4.2.8.5., renumber as 4.2.8.4. and amend to read:

"4.2.8.4. Calculation of the wet grip index of the candidate tyre

The wet grip index $G(T_n)$ of the candidate tyre T_n ($n = 1, 2, 3$) is calculated as follows:

$$G(T_n) = K_{\text{trailer}} \cdot \{ \overline{\mu_{peak}}(T_n) - [a \cdot \Delta\mu_{peak}(R) + b \cdot \Delta\vartheta + c \cdot (\Delta\vartheta)^2 + d \cdot \Delta MTD] \}$$

where:

$\overline{\mu_{peak}}(T_n)$ is the arithmetic mean of the peak braking force coefficients of the candidate tyre T_n within a braking test;

$$\Delta\mu_{peak}(R) = \mu_{peak,adj}(R) - \mu_{peak}(R_0)$$

$\mu_{peak,adj}(R)$ is the adjusted peak braking force coefficient in accordance with Table 3;

$\mu_{\text{peak}}(R_0) = 0.85$ is fixed as the peak braking force coefficient for the reference tyre in the reference conditions;

$$\Delta\vartheta = \vartheta - \vartheta_0$$

ϑ is the measured wet surface temperature in degrees Celsius when the candidate tyre T_n is tested;

ϑ_0 is the wetted surface reference temperature for the candidate tyre according to its sidewall marking as listed in Table 4;

$$\Delta MTD = MTD - MTD_0$$

MTD is the measured macro texture depth of the track

$MTD_0 = 0.8$ mm is fixed as the macro texture depth of the reference track;

$K_{\text{trailer}} = 1.50$ is a factor to grant consistency between previous calculation of the wet grip index and this one, and to ensure convergence between vehicle and trailer method and

coefficient a , b , c and d are given in Table 4.

Table 4

| Category of use | ϑ_0 (°C) | a | b (°C ⁻¹) | c (°C ⁻²) | d (mm ⁻¹) |
|---|-----------------------|----------|----------------------------|----------------------------|----------------------------|
| Normal tyre | 20 | +0.99757 | +0.00251 | -0.00028 | +0.07759 |
| Snow tyre | 15 | +0.87084 | -0.00025 | +0.00004 | -0.01635 |
| Snow tyre for use in severe snow conditions | 10 | +0.67929 | +0.00115 | -0.00005 | +0.03963 |
| Special-use tyre | not defined | | | | |

Part (B),

Paragraph 1.1., amend to read:

"1.1. Track characteristics

The surface shall be a dense asphalt surface with a uniform gradient of not more than two per cent and shall not deviate more than 6 mm when tested with a 3 m straight edge.

The test surface shall have a pavement of uniform age, composition, and wear. The test surface shall be free of loose material or foreign deposits.

The maximum chipping size shall be from 8 mm to 13 mm.

The average macro texture depth measured as specified in ASTM E 965-96 (reapproved 2006) shall be (0.7 ± 0.3) mm.

The surface friction value for the wetted track shall be established by one or other of the following methods according to the discretion of the Contracting Party."

Paragraph 1.1.1., amend to read:

"1.1.1. Standard Reference Test Tyre (SRTT) method

This method uses the Standard Reference Test Tyre SRTT16.

Using the procedure described in paragraph 4.2. of part (A) of this Annex, perform in the same area where the average macro texture depth was measured one braking test of the reference tyre, consisting of at least six (6) valid test runs in the same direction.

Evaluate the braking test as described in paragraphs 4.2.8.1. and 4.2.8.2. of part (A) of this Annex. If the coefficient of variation CV_{μ} exceeds 4 per cent, dismiss the results and repeat the braking test.

The arithmetic mean ($\overline{\mu_{\text{peak}}}$) of the measured peak braking force coefficients shall be corrected for the effects of temperature as follows:

$$\mu_{\text{peak,corr}} = \overline{\mu_{\text{peak}}} + a \cdot (\vartheta - \vartheta_0)$$

where

ϑ is the wetted track surface temperature in degrees Celsius,

$a = 0.002 \text{ } ^\circ\text{C}^{-1}$ and $\vartheta_0 = 20 \text{ } ^\circ\text{C}$.

The temperature corrected average peak braking force coefficient ($\mu_{\text{peak,corr}}$) shall be not less than 0.65 and not greater than 0.90.

The test shall be conducted using the lanes and length of the track to be used for the wet grip test.

For the trailer method, testing is run in such a way that braking occurs within 10 meters distance of where the surface was characterized."

Paragraph 1.1.2., delete.

Paragraph 1.1.3., renumber as 1.1.2.

Annex 5 – Appendix, amend to read:

"Annex 5 – Appendix

Test reports examples of wet grip index

Example 1: Test report of wet grip index using trailer or tyre test vehicle method

| | | | |
|---------------------|--|------------|--|
| Test report number: | | Test date: | |
|---------------------|--|------------|--|

| | | | |
|----------------------------|--|----------------------------|----------|
| Track: | | Minimum: | Maximum: |
| Texture depth (mm): | | Wetted surface temp. (°C): | |
| $\mu_{\text{peak,corr}}$: | | Ambient temp (°C): | |
| Water depth (mm): | | | |

| | |
|---------------|--|
| Speed (km/h): | |
|---------------|--|

| No. | 1 | 2 | 3 | 4 | 5 |
|--|---------|---|---|---|---------|
| Brand | | | | | |
| Pattern/Trade description | SRTT... | | | | SRTT... |
| Size | | | | | |
| Service description | | | | | |
| Reference (test) inflation pressure ⁽¹⁾ (kPa) | | | | | |
| Tyre identification | | | | | |
| M+S marking (Y/N) | | | | | |
| 3PMSF marking (Y/N) | | | | | |
| Rim | | | | | |

| | | | | | |
|------------------------------------|---|--|--|--|--|
| Load (kg) | | | | | |
| Pressure (kPa) | | | | | |
| μ_{peak} | 1 | | | | |
| | 2 | | | | |
| | 3 | | | | |
| | 4 | | | | |
| | 5 | | | | |
| | 6 | | | | |
| | 7 | | | | |
| | 8 | | | | |
| $\bar{\mu}_{peak}$ | | | | | |
| Standard deviation, σ_{μ} | | | | | |
| $CV_{\mu} \leq 4 \%$ | | | | | |
| $CVal(\mu_{peak}) \leq 5 \%$ | | | | | |
| $\mu_{peak,corr}(R)$ | | | | | |
| $\mu_{peak,adj}(R)$ | | | | | |
| Wet grip index | | | | | |
| Wetted surface temp. (°C) | | | | | |
| Ambient temp. (°C) | | | | | |
| Remarks | | | | | |

⁽¹⁾ for C2 and C3 tyres, corresponding to the indication of the inflation pressure marked on the sidewall as required by paragraph 4.1. of this Regulation

Example 2: Test report of wet grip index using vehicle method

| | | | | | |
|--------------------------|--|----------------------------|----------|--------------------------|------|
| Test report number: | | Test date: | | Driver: | |
| Track: | | Minimum: | Maximum: | Vehicle | |
| Texture depth (mm): | | Wetted surface temp. (°C): | | Brand: | |
| $BFC_{ave,corr,1}$: | | Ambient temp (°C): | | Model: | |
| $BFC_{ave,corr,2}$: | | | | Type: | |
| $CVal(BFC_{ave,corr})$: | | | | Year of registration: | |
| Water depth (mm): | | | | Maximum axle load: Front | Rear |
| Initial speed (km/h): | | Final speed (km/h): | | | |

| No. | 1 | 2 | 3 | 4 | 5 |
|--|---------|---|---|---|---------|
| Brand | | | | | |
| Pattern/Trade description | SRTT... | | | | SRTT... |
| Size | | | | | |
| Service description | | | | | |
| Reference (test) inflation pressure ⁽¹⁾ (kPa) | | | | | |
| Tyre identification | | | | | |
| M+S marking (Y/N) | | | | | |
| 3PMSF marking (Y/N) | | | | | |

| Rim | | | | | | | | | | | |
|------------------------------------|----|-----------------------------|------------------------|-----------------------------|------------------------|-----------------------------|------------------------|-----------------------------|------------------------|-----------------------------|------------------------|
| Front axle pressure (kPa) | | left: | right: | left: | right: | left: | right: | left: | right: | left: | right: |
| Rear axle pressure (kPa) | | left: | right: | left: | right: | left: | right: | left: | right: | left: | right: |
| Front axle load (kg) | | left: | right: | left: | right: | left: | right: | left: | right: | left: | right: |
| Rear axle load (kg) | | left: | right: | left: | right: | left: | right: | left: | right: | left: | right: |
| | | <i>Braking distance (m)</i> | <i>BFC_i</i> | <i>Braking distance (m)</i> | <i>BFC_i</i> | <i>Braking distance (m)</i> | <i>BFC_i</i> | <i>Braking distance (m)</i> | <i>BFC_i</i> | <i>Braking distance (m)</i> | <i>BFC_i</i> |
| Measurement | 1 | | | | | | | | | | |
| | 2 | | | | | | | | | | |
| | 3 | | | | | | | | | | |
| | 4 | | | | | | | | | | |
| | 5 | | | | | | | | | | |
| | 6 | | | | | | | | | | |
| | 7 | | | | | | | | | | |
| | 8 | | | | | | | | | | |
| | 9 | | | | | | | | | | |
| | 10 | | | | | | | | | | |
| \overline{BFC}_{ave} | | | | | | | | | | | |
| Standard deviation, σ_{BFC} | | | | | | | | | | | |
| $CV_{BFC} \leq 4 \%$ | | | | | | | | | | | |
| $CVal(BFC_{ave}) \leq 5 \%$ | | | | | | | | | | | |
| $BFC_{ave,corr}(R)$ | | | | | | | | | | | |
| $BFC_{adj}(R)$ | | | | | | | | | | | |
| Wet grip index | | | | | | | | | | | |
| Wetted surface temp. (°C) | | | | | | | | | | | |
| Ambient temp. (°C) | | | | | | | | | | | |
| Remarks | | | | | | | | | | | |

⁽¹⁾ for C2 and C3 tyres, corresponding to the indication of the inflation pressure marked on the sidewall as required by paragraph 4.1. of this Regulation."

Annex 7

Paragraph 1.3., amend to read:

"1.3. "Traction test" means a series of a specified number of spin-traction test runs according to ASTM standard:

- (a) F1805-06 in case SRTT14 is used as reference tyre or
 - (b) F1805-20 in case SRTT16 is used as reference tyre
- of the same tyre repeated within a short time frame."

Paragraph 2., amend to read:

"2. Spin traction method for Class C1 and C2 tyres (traction force test per paragraph 6.4. (b) of this Regulation)

The test procedure of ASTM standard F1805-06 or F1805-20, as applicable according to paragraph 1.3., shall be used to assess snow performance through the traction performance index (TPI) on medium pack snow (The snow

compaction index measured with a CTI penetrometer¹ shall be between 70 and 80)."

Paragraph 2.1., amend to read:

"2.1. The test course surface shall be composed of a medium pack snow surface, as characterized in table A2.1 of ASTM standard F1805-06 or ASTM F1805-20, as applicable."

Paragraph 2.2., amend to read:

"2.2. The tyre load for testing shall be as per option 2 in paragraph 11.9.2. of ASTM standard F1805-06 or ASTM F1805-20, as applicable. When the SRTT16 is used as reference tyre, it shall be tested with a load of 531 kg at an inflation pressure of 240 kPa (cold)."

Insert a new paragraph 2.3. to read:

"2.3. The snow grip index (SG) of a candidate tyre Tn shall be computed as follows:

$$SG(Tn) = f \cdot \frac{TPI}{100}$$

where

(a) $f = 1.000$ when using SRTT14 as reference tyre per ASTM F1805-06, and

(b) $f = 0.987$ when using SRTT16 as reference tyre per ASTM F1805-20,

and

TPI denotes the traction performance index as defined in ASTM F1805-06 or ASTM F1805-20, as applicable."

Insert a new paragraph 3.1.6. to read:

"3.1.6. In order to run this test, the Standard Reference Test Tyres (SRTT) as shown in the following table shall be used:

| Class C1 tyres | Class C2 tyres |
|------------------|----------------|
| SRTT14 or SRTT16 | SRTT16C |

"

Paragraph 3.4.1.3., amend to read:

"3.4.1.3. The snow grip index (SG) of a candidate tyre Tn shall be computed from the arithmetic mean \bar{a}_{Tn} of the mfdd of the tyre Tn and the applicable weighted average wa_{SRTT} of the SRTT as shown in the table:

$$SG(Tn) = f \cdot \frac{\bar{a}_{Tn}}{wa_{SRTT}}$$

where f is given in the following table

| Tyre class | Reference tyre | Factor |
|------------|----------------|-------------|
| C1 | SRTT14 | $f = 1.000$ |
| | SRTT16 | $f = 0.980$ |
| C2 | SRTT16C | $f = 1.000$ |

"

Paragraph 3.4.3.1., amend to read:

"3.4.3.1 The snow grip index of the control tyre C relative to the SRTT (SG1) is given by

$$SG1 = SG(C) = f \cdot \frac{\overline{a_C}}{wa_{SRTT}}$$

where f is given in paragraph 3.4.1.3., and snow grip index of the candidate tyre T_n relative to the control tyre ($SG2$) is given by

$$SG2 = \frac{\overline{a_{Tn}}}{wa_C}$$

where wa_C is the applicable weighted average of the control tyre, shall be established using the procedure in paragraphs 3.1. to 3.4.2. above.

The snow grip index of the candidate tyre relative to the SRTT $SG(T_n)$ shall be the product of the two resulting snow grip indices that is given by

$$SG(T_n) = SG1 \cdot SG2."$$

Appendix 2

Part 1, Report, amend to read:

- " ...
5. Tyre class:
6. Category of use:
7. Snow grip index SG
- 7.1. Test procedure and SRTT used
8. Comments (if any):
- ... "

Part 2, Test data, amend to read:

- " ...
5. Test results: mean fully developed decelerations ($m \cdot s^{-2}$) / traction coefficient⁽³⁾

| Run number | Specification | SRTT (1st test) | Candidate 1 | Candidate 2 | SRTT (2nd test) |
|---------------------------|-----------------------------|-----------------|-------------|-------------|-----------------|
| 1 | | | | | |
| 2 | | | | | |
| 3 | | | | | |
| 4 | | | | | |
| 5 | | | | | |
| 6 | | | | | |
| | | | | | |
| | | | | | |
| | | | | | |
| Mean | | | | | |
| Standard deviation | | | | | |
| Coefficient of variation | $CV_a \leq 6 \%$ | | | | |
| Coefficient of Validation | $CV_{Val} (SRTT) \leq 5 \%$ | X | X | X | |
| SRTT weighted average | | X | X | X | X |
| Factor f | | X | X | X | X |
| Snow grip index | | 1.00 | X | X | X |

- (1) for C2 tyres, corresponding to the indication of the inflation pressure marked on the sidewall as required by paragraph 4.1. of this Regulation

..."

23 November 2022

Agreement

Concerning the Adoption of Harmonized Technical United Nations Regulations for Wheeled Vehicles, Equipment and Parts which can be Fitted and/or be Used on Wheeled Vehicles and the Conditions for Reciprocal Recognition of Approvals Granted on the Basis of these United Nations Regulations*

(Revision 3, including the amendments which entered into force on 14 September 2017)

Addendum 116 – UN Regulation No. 117

Revision 4 - Amendment 6

Supplement 14 to the 02 series of amendments – Date of entry into force: 8 October 2022.

Uniform provisions concerning the approval of tyres with regard to rolling sound emissions and/or to adhesion on wet surfaces and/or to rolling resistance

This document is meant purely as documentation tool. The authentic and legal binding text is: ECE/TRANS/WP.29/2022/8.



UNITED NATIONS

* Former titles of the Agreement:

Agreement concerning the Adoption of Uniform Conditions of Approval and Reciprocal Recognition of Approval for Motor Vehicle Equipment and Parts, done at Geneva on 20 March 1958 (original version); Agreement concerning the Adoption of Uniform Technical Prescriptions for Wheeled Vehicles, Equipment and Parts which can be Fitted and/or be Used on Wheeled Vehicles and the Conditions for Reciprocal Recognition of Approvals Granted on the Basis of these Prescriptions, done at Geneva on 5 October 1995 (Revision 2).

*Table of contents, Annexes, amend to read:***

"Annexes

| | | |
|---|---|--|
| 1 | Communication | |
| 2 | Arrangements of approval marks | |
| | Appendix 1 | Example of separate Regulation No. 117 approval marks |
| | Appendix 2 | Approval according to Regulation No. 117 coincident with approval of Regulation No. 30 or 54 |
| | Appendix 3 | Combinations of markings approvals issued in accordance with Regulations Nos. 117, 30 or 54..... |
| | Appendix 4 | Extensions to combine approvals issued in accordance with Regulation No. 117 |
| 3 | Coast-by test method for measuring tyre-rolling sound emission | |
| | Appendix 1 | Test report |
| 4 | Specifications for the test site | |
| 5 | Test procedures for measuring wet adhesion of new tyres | |
| | Appendix | Test reports examples of wet grip index |
| 6 | Test procedure for measuring rolling resistance..... | |
| | Appendix 1 | Test equipment tolerances |
| | Appendix 2 | (omitted) |
| | Appendix 3 | Test report and test data (Rolling resistance)..... |
| | Appendix 4 | Tyre standards organizations |
| | Appendix 5 | Deceleration method: Measurements and data processing for deceleration value obtaining in differential form $d\omega/dt$ |
| 7 | Procedures for snow performance testing relative to snow tyre for use in severe snow conditions | |
| | Appendix 1 | Pictogram definition of "Alpine Symbol" |
| | Appendix 2 | Test reports and test data for classes C1 and C2 tyres |
| | Appendix 3 | Test reports and test data for class C3 tyres |
| 8 | Procedures for ice performance testing relative to ice grip tyre of class C1..... | |
| | Appendix 1 | Pictogram definition of "Ice Grip Symbol" |
| | Appendix 2 | Test reports and test data for class C1 tyres |

** Page numbers will be indicated at a later stage (*note by the secretariat*).

Paragraph 1.1., amend to read:

"1.1. This Regulation applies to new pneumatic tyres* of classes C1, C2 and C3 with regard to their sound emissions, rolling resistance and to adhesion performance on wet surfaces (wet adhesion). It does not, however, apply to:

* For the purpose of this Regulation "tyres" means "pneumatic tyres"

Paragraph 1.1.3., amend to read:

"1.1.3. Tyres designed for competition;"

Paragraph 1.1.6., amend to read:

"1.1.6. Tyres with a speed category less than 80 km/h (speed category symbol F);"

Paragraph 2.1., amend to read:

2.1. "Type of tyre" means tyres which do not differ in such essential characteristics as:

- (a) The manufacturer's name;
- (b) The tyre class (see paragraph 2.6. below);
- (c) The tyre structure;
- (d) The category of use: normal tyre, snow tyre and special use tyre;
- (e) Whether snow tyre for use in severe snow conditions or not;
- (f) For class C1 tyres, whether ice grip tyre or not;
- (g) For classes C2 and C3 tyres, whether traction tyre or not;
- (h) The tread pattern (see paragraph 3.2.1. of this Regulation)."

Paragraph 2.3., amend to read:

"2.3. "Brand name/trademark" means the identification of the brand or trademark as defined by the tyre manufacturer and marked on the sidewall(s) of the tyre. The brand name/trademark may be the same as that of the manufacturer."

Paragraphs 2.6.1. to 2.6.3., amend to read:

"2.6.1. *Class C1 tyres*: tyres conforming to UN Regulation No. 30;

2.6.2. *Class C2 tyres*: tyres conforming to UN Regulation No. 54 and identified by a load capacity index in single formation lower or equal to 121 and a speed category symbol higher or equal to "N";

2.6.3. *Class C3 tyres*: tyres conforming to UN Regulation No. 54 and identified by:

- (a) A load capacity index in single formation higher or equal to 122; or
- (b) A load capacity index in single formation lower or equal to 121 and a speed category symbol lower or equal to "M"."

Paragraph 2.7., amend to read:

"2.7. "Representative tyre size" means the tyre size which is submitted to the test described in Annex 3 to this Regulation with regard to rolling sound emissions, or Annex 5 for adhesion on wet surfaces or Annex 6 for rolling resistance to assess the conformity for the type approval of the type of tyre, or Annex 7 for measuring snow performance, or Annex 8 for measuring ice performance."

Paragraph 2.11., amend to read:

"2.11. "Reinforced tyre" or "extra load tyre" of class C1 means a tyre structure designed to carry more load at a higher inflation pressure than the load carried

by the corresponding standard version tyre at the standard inflation pressure as specified in ISO 4000-1:2010²"

Paragraph 2.12., amend to read:

"2.12. *"Traction tyre"* means a tyre in classes C2 or C3 bearing the inscription TRACTION and intended to be fitted primarily to the drive axle(s) of a vehicle to maximize force transmission in various circumstances."

Paragraph 2.13.1., amend to read:

"2.13.1. *"Snow tyre for use in severe snow conditions"* means a snow tyre whose tread pattern, tread compound or structure is specifically designed to be used in severe snow conditions and that fulfils the requirements of paragraphs 6.4. and 6.4.1. of this Regulation."

Insert a new paragraph 2.13.1.1., to read:

"2.13.1.1. *"Ice grip tyre"* means a class C1 snow tyre for use in severe snow conditions that is additionally designed to be used on road surfaces covered with ice and that fulfils the requirements of paragraph 6.4.2. of this Regulation."

Paragraph 2.18., amend to read:

"2.18. *"Standard Reference Test Tyre"* or *"SRTT"* means a tyre that is produced, controlled and stored in accordance with the standards of ASTM International:

- (a) E1136 – 17 for the size P195/75R14 and referred to as "SRTT14",
- (b) F2493 – 20 for the size P225/60R16 and referred to as "SRTT16",
- (c) F2872 – 16 for the size 225/75R16C and referred to as "SRTT16C",
- (d) F2871 – 16 for the size 245/70R19.5 and referred to as "SRTT19.5",
- (e) F2870 – 16 for the size 315/70R22.5 and referred to as "SRTT22.5".

Paragraph 2.19., amend to read:

"2.19. Wet adhesion or snow performance or ice performance measurements – Specific definitions"

Paragraph 2.19.1., amend to read:

"2.19.1. *"Adhesion on wet surfaces"* or *"wet adhesion"* means the relative braking performance, on a wet surface, of a test vehicle equipped with the candidate tyre in comparison to that of the same test vehicle equipped with a Standard Reference Test Tyre (SRTT)."

Paragraph 2.19.2., amend to read:

"2.19.2. *"Candidate tyre"* or *"candidate tyre set"* means a tyre or a tyre set, representative of the type that is submitted for approval in accordance with this Regulation and whose performances are evaluated relative to that of a reference tyre or reference tyre set."

Insert a new paragraph 2.19.3., to read:

"2.19.3. *"Reference tyre"* or *"reference tyre set"* means a tyre or a tyre set of Standard Reference Test Tyres as defined in the respective annex."

Paragraph 2.19.3., renumber as 2.19.4. and amend to read:

"2.19.4. *"Control tyre"* or *"control tyre set"* means a normal production tyre or a normal production tyre set that is used to establish the wet adhesion level or snow performance level or ice performance level of tyre sizes unable to be fitted to the same vehicle as the reference tyre or reference tyre set – see paragraph 2.2.2.8. of Annex 5, part (B), paragraph 3.4.3. of Annex 7 and paragraph 2.4.5.1.1. of Annex 8 to this Regulation."

Insert a new paragraph 2.19.5., to read:

"2.19.5. "Test tyre" means a candidate tyre, reference tyre or control tyre."

Paragraph 2.19.4., renumber as 2.19.6. and amend to read:

"2.19.6. "Wet grip index" (G) means the dimensionless unit for expressing the wet adhesion level of a candidate tyre relative to that of the applicable SRTT."

Paragraph 2.19.5., renumber as 2.19.7. and amend to read:

"2.19.7. "Snow grip index" (SG) means the dimensionless unit for expressing the snow performance level of a candidate tyre relative to the performance of the applicable SRTT."

Insert a new paragraph 2.19.8., to read:

"2.19.8. "Ice grip index" (G_I) means the dimensionless unit for expressing the ice performance level of a candidate tyre relative to the performance of the applicable SRTT."

Paragraphs 2.19.6. to 2.19.8., renumber as 2.19.9. to 2.19.11.

Insert new paragraphs 2.19.12. to 2.19.16., to read:

"2.19.12. "Test run" means a single pass of a loaded tyre over a given test surface.

2.19.13. "Braking test" means a series of a specified number of test runs of the same test tyre repeated within a short time frame.

2.19.14. "Traction test" means a series of a specified number of spin-traction test runs of the same tyre repeated within a short time frame.

2.19.15. "Acceleration test" means a series of specified number of traction controlled acceleration test runs of the same tyre repeated within a short timeframe.

2.19.16. "Test cycle" means a series of braking tests, traction tests or acceleration tests that consist of an initial test of the reference tyre or the control tyre, of tests of candidate tyres and/or control tyres and a final test of the same reference tyre or control tyre."

Paragraph 2.20.1., amend to read:

"2.20.1. "Rolling resistance" (F_r) means the loss of energy (or energy consumed) per unit of distance travelled.³"

Footnote 3, amend to read:

³ The International System of Units (SI) unit conventionally used for the rolling resistance is the newton-metre per metre, which is equivalent to a drag force in newton."

Paragraph 2.20.2., amend to read:

"2.20.2. "Rolling resistance coefficient" (C_r) means the ratio of the rolling resistance to the load on the tyre.⁴"

Paragraph 2.20.4., amend to read:

"2.20.4. "Laboratory control tyre" means a tyre used by an individual laboratory to control machine behaviour as a function of time.⁷"

Paragraph 2.20.5., amend to read:

"2.20.5. "Capped inflation" means the process of inflating the tyre to the required cold inflation pressure and allowing the inflation pressure to build up, as the tyre is warmed up while running."

Paragraph 2.20.6., amend to read:

"2.20.6. "Parasitic loss" means the loss of energy (or energy consumed) per unit distance excluding internal tyre losses, attributable to aerodynamic loss of the

different rotating elements of the test equipment, bearing friction and other sources of systematic loss which may be inherent in the measurement."

Paragraph 2.20.7., amend to read:

"2.20.7. "Skim test reading" means a type of parasitic loss measurement, in which the tyre is kept rolling without slippage, while reducing the tyre load to a level at which energy loss within the tyre itself is virtually zero."

Paragraph 2.20.8., amend to read:

"2.20.8. "Inertia" or "moment of inertia" means the ratio of the torque applied to a rotating body, such as a tyre assembly or machine drum, to the rotational acceleration of this body.⁸"

Paragraph 2.20.9., amend to read:

"2.20.9. "Measurement reproducibility" (σ_m) means the capability of a machine to measure rolling resistance.⁹"

Paragraph 3.1.1., amend to read:

"3.1.1. The performance characteristics to be assessed for the type of tyre; "rolling sound emissions level" and/or "adhesion performance level on wet surfaces" and/or "rolling resistance level"; "snow performance level" in case of "snow tyre for use in severe snow conditions" and additionally "ice performance level" in case of ice grip tyre;"

Paragraph 3.1.5.1., amend to read:

"3.1.5.1. Whether snow tyre for use in severe snow conditions or not;"

Paragraph 3.1.5.2., amend to read:

"3.1.5.2. For classes C2 and C3 tyres, whether traction tyre or not;"

Insert a new paragraph 3.1.5.3., to read:

"3.1.5.3. For class C1 tyres, whether ice grip tyre or not;"

Paragraph 3.1.8., amend to read:

"3.1.8. A list of tyre size designations covered by this application and specifying for each brand name/trademark and/or each trade description/commercial name the applicable tyre size designations and service descriptions, adding in case of class C1 tyres whether "reinforced" (or "extra load") or not."

Paragraph 3.2.1., amend to read:

"3.2.1. Details of the major features, with respect to the effects on the performance (i.e. rolling sound emission level, adhesion on wet surfaces, rolling resistance, snow performance and ice performance) of the tyres, including the tread pattern, included in the designated range of tyre sizes. This may be by means of descriptions supplemented by technical data, drawings, photographs or Computer Tomography (CT) scans, and must be sufficient to allow the Type Approval Authority or Technical Service to determine whether any subsequent changes to the major features will adversely affect the tyre performance. The effects of changes to minor details of tyre construction on tyre performances will be evident and determined during checks on conformity of production;"

Paragraph 3.2.2., amend to read:

"3.2.2. Drawings or photographs of the tyre sidewall, showing the approval marks referred to in paragraph 4., shall be submitted once the production has been established, but no later than one year after the date of granting of type approval;"

Paragraph 4.2.1., amend to read:

"4.2.1. The manufacturer's name or the brand name/trademark;"

Paragraph 4.2.2., amend to read:

"4.2.2. The trade description/commercial name (see paragraph 2.4. of this Regulation). However, the trade description is not required when it coincides with the brand name/trademark;"

Paragraph 4.2.6., amend to read:

"4.2.6. The "Alpine Symbol" ("3-peak-mountain with snowflake" conforming to the pictogram described in Annex 7, Appendix 1) if the snow tyre is classified as "snow tyre for use in severe snow conditions";"

Insert a new paragraph 4.2.6.1., to read:

"4.2.6.1. The "Ice Grip Symbol" (conforming to the pictogram described in Annex 8, Appendix 1) if the snow tyre for use in severe snow conditions is additionally classified as ice grip tyre;"

Paragraph 4.3.1., amend to read:

"4.3.1. In case the approval of a tyre pursuant to this Regulation has been granted by the same Type Approval Authority than that granting the approval pursuant to UN Regulations Nos. 30 or 54, the approval mark pursuant to UN Regulations Nos. 30 or 54 can be combined with an indication of the applicable series of amendments to which the tyre was approved pursuant to UN Regulation No. 117 on the form of 2 digits (example "02" indicating that the UN Regulation No.117 approval was granted following the 02 series of amendments) and the suffixes according to paragraph 5.2.2. using the addition sign "+", as described in Annex 2, Appendix 3 of this Regulation, for example "0236378 + 02S1WR2"."

Paragraph 5.2.1., amend to read:

"5.2.1. Instead of granting the original type approval number pursuant to UN Regulation No. 117, upon the request of the manufacturer, the Type Approval Authority may grant the type approval number, which had been granted before to that type of tyre pursuant to UN Regulations Nos. 30 or 54 with the subsequent extension number."

Paragraph 5.2.2., amend to read:

"5.2.2. The communication form mentioned in paragraph 5.3. below shall identify specific performance parameters of UN Regulation No. 117 by the following suffixes: ..."

Paragraph 5.3.1., amend to read:

"5.3.1. With reference to paragraph 5.2.1. above, tyre manufacturers are entitled to submit an application for extension of type approval to the requirements of other Regulations relevant to the type of tyre. In that case, a copy of the relevant type approval communication(s), as issued by the relevant Type Approval Authority, shall be attached to the application for extension of approval. All applications for extension of approval(s) shall only be granted by the Type Approval Authority which issued the original approval for the tyre."

Paragraph 5.3.1.1., amend to read:

"5.3.1.1. When extension of approval is granted to incorporate into the communication form (see Annex 1 to this Regulation) certification(s) of conformity to other Regulations, (all) the specific type approval number(s) and the Regulation itself shall be added to item 9. of Annex 1 "Communication"."

Paragraph 5.3.1.2., amend to read:

"5.3.1.2. The suffix(es) mentioned in paragraph 5.2.2. above shall be preceded by the two digits identifying the series of amendments of the prescription on tyre performances for UN Regulation No. 117, e.g. "02S2" to identify the second series of amendments on tyre road rolling sound emissions at stage 2 or

"02S1WR1" to identify the second series of amendments on tyre road rolling sound emissions at stage 1, tyre adhesion on wet surfaces and rolling resistance at stage 1 (see paragraph 6.1. below for stage 1 and stage 2 definitions)."

Paragraph 5.4.3., amend to read:

"5.4.3. The suffix(es), and the identification to the relevant series of amendments, if any, as specified in the communication form.

One of the suffixes listed below or any combination of them can be used.

| | |
|----|---|
| S1 | Rolling sound emission level at stage 1 |
| S2 | Rolling sound emission level at stage 2 |
| W | Wet adhesion level |
| R1 | Rolling resistance level at stage 1 |
| R2 | Rolling resistance level at stage 2 |

These suffixes shall be placed to the right or below the approval number, if part of the original approval.

If the approval is extended subsequent to UN Regulations Nos. 30 or 54 approvals, the addition sign "+" and the series of amendment to UN Regulation No. 117 shall be placed in front of the suffix or any combination of suffixes to denote an extension to the approval.

If the approval is extended subsequent to the original approval under UN Regulation No. 117, the addition sign "+" shall be placed between the suffix or any combination of suffixes of the original approval and the suffix or any combination of suffixes added to denote an extension to the approval."

Paragraph 6.1.1., amend to read:

"6.1.1. For class C1 tyres, the rolling sound emission value shall not exceed the values pertinent to the applicable stage given below. These values refer to the nominal section width as defined in UN Regulation No. 30: ..."

Paragraph 6.1.2., amend to read:

"6.1.2. For class C2 tyres, the rolling sound emission value with reference to its category of use (see paragraph 2.1., subparagraph (d) above) shall not exceed the values pertinent to the applicable stage given below: ..."

Paragraph 6.1.3., amend to read:

"6.1.3. For class C3 tyres, the rolling sound emission value with reference to its category of use (see paragraph 2.1., subparagraph (d) above) shall not exceed the values pertinent to the applicable stage given below: ..."

Paragraph 6.2., amend to read:

"6.2. The wet adhesion will be based on a procedure that compares either peak brake force coefficient ("pbfc") or mean fully developed deceleration ("mfdd") against values achieved by a Standard Reference Test Tyre (SRTT). The relative performance shall be indicated by a wet grip index (G)."

Paragraph 6.2.1., amend to read:

"6.2.1. For class C1 tyres, tested in accordance with either procedure given in Annex 5, Part (A), to this Regulation, the tyre shall meet the following requirements:

| <i>Category of use</i> | | <i>Wet grip index (G)</i> |
|------------------------|--|---------------------------|
| Normal tyre | | ≥ 1.1 |

| <i>Category of use</i> | | <i>Wet grip index (G)</i> |
|------------------------|--|---------------------------|
| Snow tyre | | ≥ 1.1 |
| | "Snow tyre for use in severe snow conditions" and with a speed category symbol ("R" and above, including "H") indicating a maximum permissible speed greater than 160 km/h | ≥ 1.0 |
| | "Snow tyre for use in severe snow conditions" and with a speed category symbol ("Q" or below excluding "H") indicating a maximum permissible speed not greater than 160 km/h | ≥ 0.9 |
| Special use tyre | | Not defined |

"

Paragraph 6.2.2., amend to read:

"6.2.2. For class C2 tyres, tested in accordance with either procedure given in Annex 5, Part (B), to this Regulation, the tyre shall meet the following requirements: ..."

Paragraph 6.2.3., amend to read:

"6.2.3. For class C3 tyres, tested in accordance with either procedure given in Annex 5, Part (B), to this Regulation, the tyre shall meet the following requirements: ..."

Paragraphs 6.4.1. and 6.4.1.1., merge and amend to read:

"6.4.1. Snow performance requirements for classes C1, C2 and C3 tyres

The minimum snow grip index value, as calculated in the procedure described in Annex 7 and compared with the respective Standard Reference Test Tyre (SRTT) shall be as follows: ..."

Insert a new paragraph 6.4.2., to read:

"6.4.2. Ice performance requirements for class C1 tyres classified as ice grip tyre

In order to be classified as ice grip tyre, a snow tyre for use in severe snow conditions shall meet the minimum ice grip index value, as calculated in the procedure described in Annex 8 and compared with the respective Standard Reference Test Tyre (SRTT) shall be as follows:

| <i>Class of tyre</i> | <i>Ice grip index</i> |
|----------------------|-----------------------|
| | <i>Ref. = SRTT16</i> |
| C1 | 1.18 |

"

Paragraph 6.5., amend to read:

"6.5. In order to be classified as a "traction tyre", a tyre is required to meet the condition of paragraph 6.5.1. below."

Paragraph 6.5.1., amend to read:

"6.5.1. The tyre shall have a tread pattern with minimum two circumferential ribs, each containing a minimum of 30 block-like elements, separated by grooves and/or sipe elements the depth of which has to be minimum of one half of the tread depth. The use of an alternative option of a physical test will only apply at a later stage following a further amendment to the Regulation including a reference to appropriate test methods and limit values."

Paragraph 6.6., amend to read:

"6.6. In order to be classified as a "special use tyre" a tyre shall have a block tread pattern in which the blocks are larger and more widely spaced than for normal tyres and have the following characteristics:

For class C1 tyres: a tread depth \geq 11 mm and void to fill ratio \geq 35 per cent;

For class C2 tyres: a tread depth \geq 11 mm and void to fill ratio \geq 35 per cent;

For class C3 tyres: a tread depth \geq 16 mm and void to fill ratio \geq 35 per cent."

Paragraph 6.7., amend to read:

"6.7. In order to be classified as a "professional off-road tyre", a tyre shall have all of the following characteristics:

(a) For classes C1 and C2 tyres:

(i) A tread depth \geq 11 mm;

(ii) A void-to-fill ratio \geq 35 per cent;

(iii) A maximum speed ~~rating~~-category symbol of \leq Q.

(b) For class C3 tyres:

(i) A tread depth \geq 16 mm;

(ii) A void-to-fill ratio \geq 35 per cent;

(iii) A maximum speed category symbol of \leq K."

Paragraph 8., amend to read:

"... The conformity of production procedures shall comply with those set out in the 1958 Agreement, Schedule 1 (E/ECE/324-E/ECE/TRANS/505/Rev.3) with the following requirements:"

Paragraph 8.2., amend to read:

"8.2. The authority which has granted type approval may at any time verify the conformity control methods applied by the manufacturer. In general, the conformity control methods should take into consideration the production volumes of the type of tyre at each manufacturing facility. The normal frequency of these verifications shall be at least once every two years."

Insert a new paragraph 8.3., to read:

"8.3. Verification tests shall be carried out on random samples of tyres bearing the approval mark required by this Regulation taken from the series production. Where the test procedure involves testing a number of tyres at the same time, for example a set of four tyres for the purpose of measuring wet adhesion in accordance with the standard vehicle procedure given in Annex 5 to this Regulation, then the set shall be considered as being one unit for the purposes of calculating the number of tyres to be tested. The Type Approval Authority shall satisfy itself that all tyres falling within an approved type comply with the approval requirement."

Paragraph 8.2.1., renumber as 8.3.1. and amend to read:

"8.3.1. In the case of verification tests with regard to approvals in accordance with paragraph 6.2. of this Regulation, these shall be carried out using the same testing method (see Annex 5 to this Regulation) as that adopted for original approval."

Insert a new paragraph 8.3.2., to read:

"8.3.2. In the case of verification tests with regard to approvals in accordance with paragraph 6.4. of this Regulation, these shall be carried out using the same

testing method (see Annex 7 to this Regulation) as that adopted for original approval."

Paragraphs 8.3. and 8.4., renumber as 8.4. and 8.5., respectively.

Paragraph 9.1., amend to read:

"9.1. The approval granted in respect of a type of tyre pursuant to this Regulation may be withdrawn if the requirements laid down in paragraph 8. above are not complied with, or if any tyre of the type of tyre exceeds the limits given in paragraphs 8.4. or 8.5. above."

Paragraph 12.1., amend to read:

"12.1. As from the date of entry into force of the 02 series of amendments to this Regulation, Contracting Parties applying this Regulation shall not refuse to grant approval under this Regulation for a type of tyre if the tyre complies with the requirements of the 02 series of amendments, including the stage 1 or stage 2 rolling sound requirements set out in paragraphs 6.1.1. to 6.1.3. of this Regulation, the requirements for wet adhesion set out in paragraph 6.2.1. of this Regulation, and the stage 1 or stage 2 rolling resistance requirements set out in paragraph 6.3.1. or 6.3.2. of this Regulation."

Paragraph 12.2., amend to read:

"12.2. As from 1 November 2012, Contracting Parties applying this Regulation shall refuse to grant approval if the type of tyre to be approved does not meet the requirements of this Regulation as amended by the 02 series of amendments, and shall, in addition, refuse to grant approval if the stage 2 rolling sound requirements set out in paragraphs 6.1.1. to 6.1.3. of this Regulation, the requirements for wet adhesion set out in paragraph 6.2.1. of this Regulation, and the stage 1 rolling resistance requirements set out in paragraph 6.3.1. of this Regulation are not complied with."

Paragraph 12.3., amend to read:

"12.3. As from 1 November 2014, Contracting Parties applying this Regulation may refuse to allow the sale or entry into service of a tyre which does not meet the requirements of this Regulation as amended by the 02 series, and which does not meet the requirements of this Regulation as amended by the 02 series of amendments including the wet adhesion requirements set out in paragraph 6.2.1. of this Regulation."

Paragraph 12.4., amend to read:

"12.4. As from 1 November 2016, Contracting Parties applying this Regulation shall refuse to grant approvals if the type of tyre to be approved does not meet the requirements of this Regulation as amended by the 02 series of amendments including the stage 2 rolling resistance requirements set out in paragraph 6.3.2. of this Regulation and the wet adhesion requirements set out in paragraphs 6.2.2. and 6.2.3. of this Regulation."

Paragraph 12.7., amend to read:

"12.7. As from the dates given below, any Contracting Party applying this Regulation may refuse to allow the sale or entry into service of a tyre which does not meet the requirements of this Regulation as amended by the 02 series, and which does not meet the stage 2 rolling resistance requirements set out in paragraph 6.3.2. of this Regulation and the wet adhesion requirements set out in paragraphs 6.2.2. and 6.2.3. of this Regulation:

| <i>Tyre class</i> | <i>Date</i> |
|-------------------|-----------------|
| C1 and C2 | 1 November 2018 |
| C3 | 1 November 2020 |

"

Paragraph 12.12., amend to read:

"12.12. Until 1 September 2024, Contracting Parties applying this Regulation may continue to grant type approvals according to the 02 series of amendments to this Regulation, based on the test procedures for measuring wet adhesion described in Annex 5 of this Regulation, without taking into account the provisions of Supplement 13."

Insert a new paragraph 12.13., to read:

"12.13. Until 3 months after the date of entry into force of Supplement 14 to the 02 series of amendments to this Regulation, Contracting Parties applying this Regulation can continue to grant type approvals according to the 02 series of amendments to this Regulation, without taking into account the provisions of Supplement 14."

Annex 1,

Insert a new item 4.1.1., to read:

"4.1.1. Ice grip tyre (Yes/No)²"

Item 6., amend to read:

"6. Type of tyre designation:"

Item 6.2., amend to read:

"6.2. Trade description(s)/commercial name(s) of the type of tyre: "

Item 8.2., amend to read:

"8.2. Wet adhesion level of the representative tyre size, see paragraph 2.7. of this Regulation, as per the test report examples shown in the appendix to Annex 5: (G) using the vehicle or trailer method²"

Item 8.4., amend to read:

"8.4. Snow performance level of the representative tyre size, see paragraph 2.7. of Regulation No. 117, as per item 7. of the test report in the appendix⁵ to Annex 7:..... (snow grip index) using the brake on snow method², spin traction method² or acceleration method.²"

Insert a new item 8.4.1., to read:

"8.4.1. Ice performance level of the representative tyre size, see paragraph 2.7. of Regulation No. 117, as per item 7. of the test report in the appendix 2 to Annex 8:.....(ice grip index) using the brake on ice method.²"

Footnote 5., amend to read:

"⁵Appendix 2 for classes C1 and C2 tyres.
Appendix 3 for class C3 tyres."

Item 16.2., amend to read:

"16.2. A list of tyre size designations: Specify for each brand name/trademark and/or each trade description/commercial name the list of tyre size designations and service descriptions, adding in case of class C1 tyres whether "reinforced" (or "extra load") or not."

Annex 2

Title, amend to read:

"Annex 2

Arrangements of approval marks"

Annex 2 - Appendix 1, amend to read:

"Annex 2 - Appendix 1

Examples of separate UN Regulation No. 117 approval marks

Approval according to UN Regulation No. 117 (see paragraph 5.4. of this Regulation)

Example 1

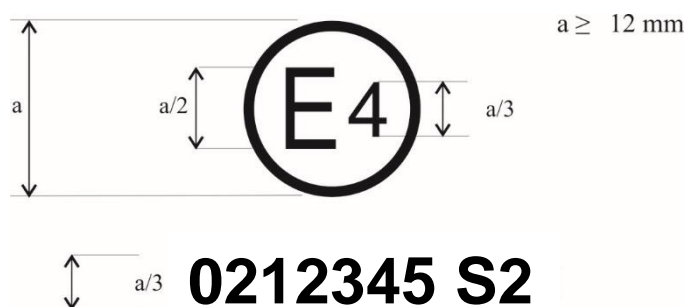

The above approval mark, affixed to a tyre shows that a tyre concerned has been approved in the Netherlands (E 4) pursuant to Regulation No. 117 (marked by "S2"), under approval number 0212345. This indicates that the approval is for rolling sound at stage 2 (S2). The first two digits of the approval number (02) indicate that the approval was granted in accordance with this Regulation which included 02 series of amendments.

Example 2

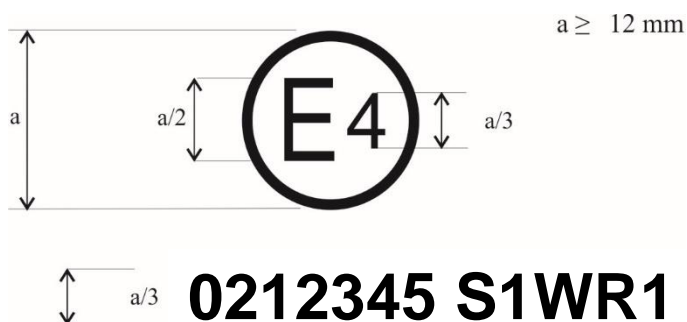

The above approval mark shows that the tyre concerned has been approved in the Netherlands (E 4) pursuant to Regulation No. 117 (marked by "S1WR1") under approval number 0212345. This indicates that the approval is for rolling sound at stage 1 (S1), wet adhesion (W) and rolling resistance at stage 1 (R1). The first two digits of the approval number ("02") indicate that the approval was granted in accordance with this Regulation which included the 02 series of amendments."

Annex 2 - Appendix 2, delete footnote 1 and amend to read:

"Annex 2 - Appendix 2

Approval according to UN Regulation No. 117 coincident with approval of UN Regulations Nos. 30 or 54

Example 1

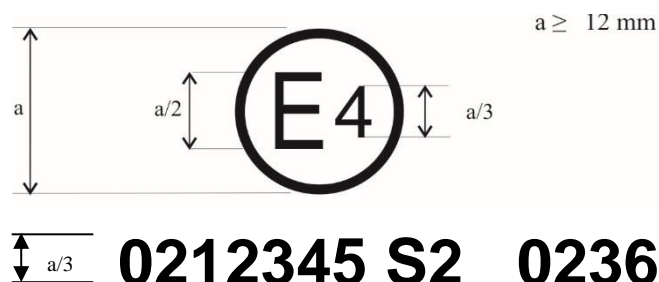

The above approval mark shows that the tyre concerned has been approved in the Netherlands (E 4) pursuant to UN Regulation No. 117 (marked by "S2"), under approval number 0212345 and UN Regulation No. 30, under approval number 0236378. This indicates that the approval is for rolling sound at stage 2 (S2). The first two digits of the approval number ("02") in conjunction with "S2" indicate that the approval was granted in accordance with UN Regulation No. 117 which included the 02 series of amendments. The first two digits of the UN Regulation No. 30 approval number ("02") indicate that this Regulation included the 02 series of amendments.

Example 2

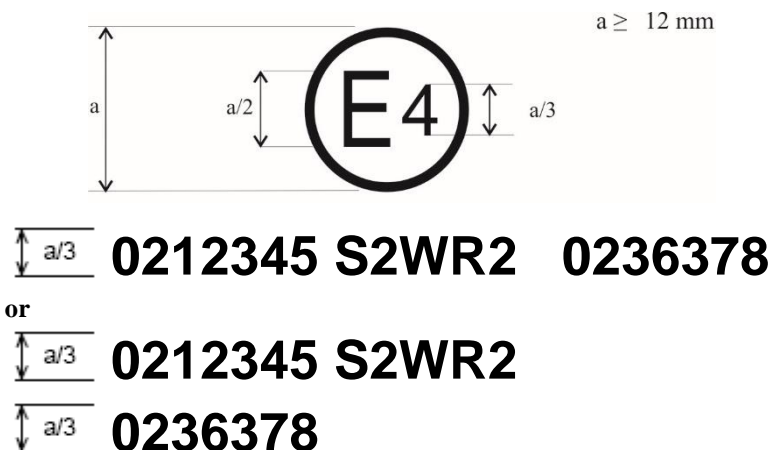

The above approval mark shows that the tyre concerned has been approved in the Netherlands (E 4) pursuant to UN Regulation No. 117 (marked by "S2WR2"), under approval number 0212345 and UN Regulation No. 30, under approval number 0236378. This indicates that the approval is for rolling sound at stage 2 (S2), wet adhesion (W) and rolling resistance at stage 2 (R2). The first two digits of the approval number ("02") in conjunction with "S2WR2" indicate that the first approval was granted in accordance with UN Regulation No. 117 which included the 02 series of amendments. The first two digits of the UN Regulation No. 30 approval number ("02") indicate that this Regulation included the 02 series of amendments.

Example 3

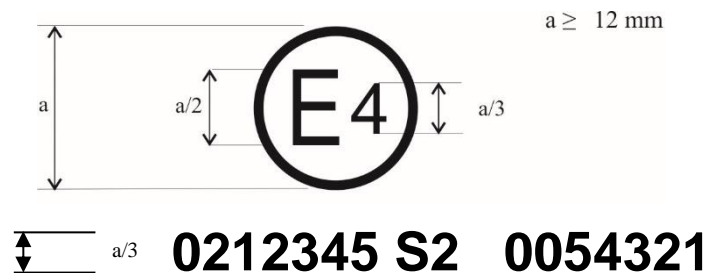

The above approval mark shows that the tyre concerned has been approved in the Netherlands (E 4) pursuant to UN Regulation No. 117 and the 02 series of amendments under approval number 0212345 (marked by "S2"), and UN Regulation No. 54, under approval number 0054321. This indicates that the approval is for rolling sound stage 2 (S2). The first two digits of the UN Regulation No. 117 approval number ("02") in conjunction with "S2" indicate that the first approval was granted in accordance with UN Regulation No. 117 which included the 02 series of amendments. The first two digits of the UN Regulation No. 54 approval number ("00") indicate that this Regulation was in its original form.

Example 4

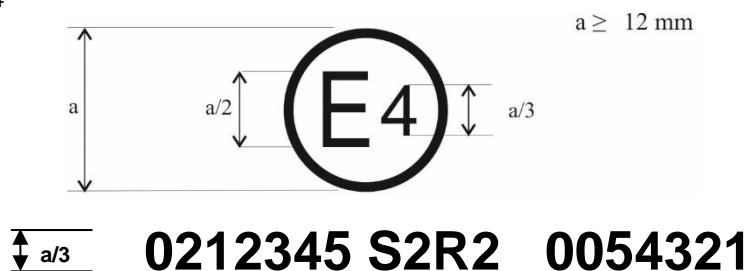

The above approval mark shows that the tyre concerned has been approved in the Netherlands (E 4) pursuant to UN Regulation No. 117 and the 02 series of amendments under approval number 0212345 (marked by "S2R2"), and UN Regulation No. 54, under approval number 0054321. This indicates that the approval is for rolling sound stage 2 (S2) and rolling resistance stage 2 (R2). The first two digits of the UN Regulation No. 117 approval number ("02") in conjunction with "S2R2" indicate that the first approval was granted in accordance with UN Regulation No. 117 which included the 02 series of amendments. The first two digits of the UN Regulation No. 54 approval number ("00") indicate that this Regulation was in its original form."

Annex 2 - Appendix 3, amend to read:

"Annex 2 - Appendix 3

Combinations of markings of approvals issued in accordance with UN Regulations Nos. 117, 30 or 54

Example 1

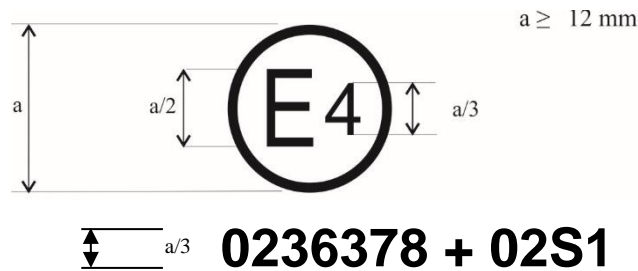

The above approval mark shows that the tyre concerned has been approved in the Netherlands (E 4) pursuant to UN Regulation No. 30 according to its 02 series of amendments (indicated by the first two digits of the approval number, "02") under approval number 0236378. It is also marked by "+ 02S1" which indicates that the tyre was also approved pursuant to UN Regulation No. 117 (02 series of amendments) for rolling sound at stage 1.

Example 2

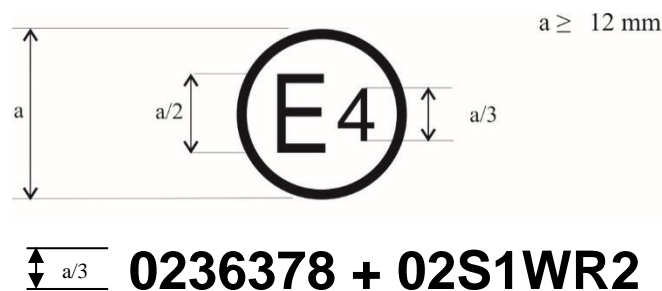

The above approval mark shows that the tyre concerned has been approved in the Netherlands (E 4) pursuant to Regulation No. 30 according to its 02 series of amendments (indicated by the first two digits of the approval number, "02") under approval number 0236378. It is also marked by "+ 02S1WR2" which indicates that the tyre was also approved pursuant to UN Regulation No. 117 (02 series of amendments) for S1 (rolling sound at stage 1), W (wet adhesion) and R2 (rolling resistance at stage 2)."

Annex 2 - Appendix 4, delete footnote 1 amend to read:

"Annex 2 - Appendix 4

Extensions to combine approvals issued in accordance with Regulation No. 117

Example 1

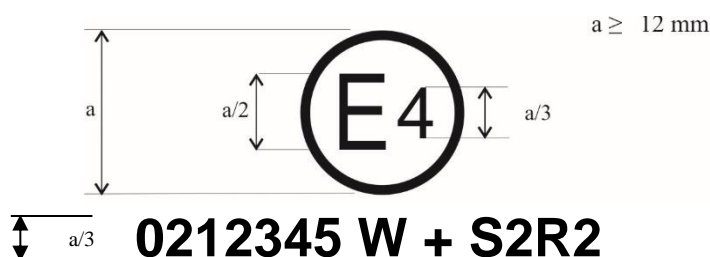

The above approval mark shows that the tyre concerned has been initially approved in the Netherlands (E 4) pursuant to UN Regulation No. 117 according to its 02 series of amendments (indicated by the first two digits of the approval number, "02") under approval number 0212345 (marked by "W"). This indicates that the approval is for W (wet adhesion). The "S2R2" preceded by "+" indicates that its approval has been extended under UN Regulation No. 117 to rolling sound at stage 2 and rolling resistance at stage 2 based on separate certificate(s).

Example 2

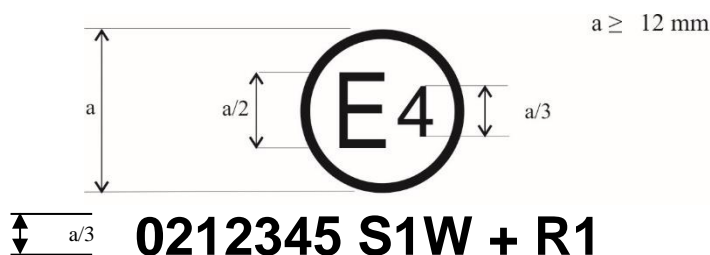

The above approval mark shows that the tyre concerned has been initially approved in the Netherlands (E 4) pursuant to UN Regulation No. 117 according to its 02 series of amendments (indicated by the first two digits of the approval number, "02") under approval number 0212345 (marked by "S1W"). This indicates that the approval is for S1 (rolling sound at stage 1) and W (wet adhesion). The "R1" preceded by "+" indicates that its approval has been extended under Regulation No. 117 to rolling resistance at stage 1 based on separate certificate(s).

Example 3

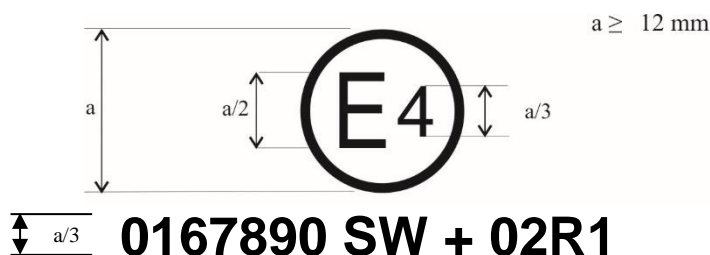

The above approval mark shows that the tyre concerned has been initially approved in the Netherlands (E 4) pursuant to UN Regulation No. 117 according to its 01 series of amendments (indicated by the first two digits of the approval number, "01") under approval

number 0167890 (marked by "SW"). This indicates that the approval is for S (rolling sound at stage 1) and W (wet adhesion). The "02R1" preceded by "+" indicates that its approval has been extended under UN Regulation No. 117 according to its 02 series of amendments to rolling resistance at stage 1 based on separate certificate(s)."

Annex 3,

Paragraph 2.4.3., amend to read:

"2.4.3. Wheelbase

The wheelbase between the two axles fitted with the test tyres shall for class C1 be less than 3.50 m and for class C2 and class C3 tyres be less than 5 m."

Paragraph 2.5.1., amend to read:

"2.5.1. General

Four identical tyres shall be fitted on the test vehicle. In the case of class C3 tyres with a load capacity index in excess of 121 and without any dual fitting indication, two of these tyres of the same type and range shall be fitted to the rear axle of the test vehicle; the front axle shall be fitted with tyres of size suitable for the axle load and planed down to the minimum depth in order to minimize the influence of tyre/road contact noise while maintaining a sufficient level of safety.

In the case of class C2 tyres with a load capacity index lower or equal to 121, with a section width wider than 200 mm, an aspect ratio lower than 55, a rim diameter code lower than 15 and without any dual fitting indication, two of these tyres of the same type and range shall be fitted to the rear axle of the test vehicle; the front axle shall be fitted with tyres of a size suitable for the axle load and planed down to the minimum depth in order to minimize the influence of tyre/road contact noise while maintaining a sufficient level of safety.

Tyres with special fitting requirements shall be tested in accordance with these requirements (e.g. rotation direction). The tyres shall have full tread depth before being run-in.

Tyres are to be tested on rims permitted by the tyre manufacturer."

Paragraph 2.5.3., amend to read:

"2.5.3. Tyre inflation pressure

Each tyre fitted on the test vehicle shall have a test pressure P_t not higher than the reference pressure P_r and within the interval:

$$P_r \times \left(\frac{Q_t}{Q_r} \right)^{1.25} \leq P_t \leq 1.1 P_r \times \left(\frac{Q_t}{Q_r} \right)^{1.25}$$

For class C2 and class C3 the reference pressure P_r is the inflation pressure corresponding to the indication of the inflation pressure marked on the sidewall as required by paragraph 4.1. of this Regulation.

For class C1 the reference pressure is $P_r = 250$ kPa for "standard" tyres and 290 kPa for "reinforced" or "extra load" tyres; the minimum test pressure shall be $P_t = 150$ kPa."

Paragraph 3.3., amend to read:

"3.3. Test speed range

The test vehicle speeds shall be within the range:

- (a) From 70 to 90 km/h for class C1 and class C2 tyres;
- (b) From 60 to 80 km/h for class C3 tyres."

Paragraph 4., amend to read:

- "4. Interpretation of results
The measurement shall be invalid if an abnormal discrepancy between the values is recorded (see paragraph 2.3.2. of this Annex)."

Paragraph 4.1., amend to read:

- "4.1. Determination of test result
Reference speed V_{ref} used to determine the final result will be:
(a) 80 km/h for class C1 and class C2 tyres;
(b) 70 km/h for class C3 tyres."

Paragraph 4.2., amend to read:

- "4.2. Temperature correction
For class C1 and class C2 tyres, the rolling sound levels $L_i(\vartheta_i)$ obtained at the test surface temperature ϑ_i (where i denotes the number of the single measurement) shall be normalized to a test surface reference temperature ϑ_{ref} by applying a temperature correction, according to the following formula:

$$L_i(\vartheta_{ref}) = L_i(\vartheta_i) + K(\vartheta_{ref} - \vartheta_i)$$

where:

$$\vartheta_{ref} = 20 \text{ }^\circ\text{C},$$

For class C1 tyres, the coefficient K is:

$$-0.03 \text{ dB(A)/}^\circ\text{C when } \vartheta_i > \vartheta_{ref} \text{ and}$$

$$-0.06 \text{ dB(A)/}^\circ\text{C when } \vartheta_i < \vartheta_{ref}.$$

For class C2 tyres, the coefficient K is $-0.02 \text{ dB(A)/}^\circ\text{C}$.

Notwithstanding the above procedure, the temperature correction may be made only on the final reported tyre rolling sound level L_R , utilizing the arithmetic mean value of the measured temperatures, if the measured test surface temperature does not change more than $5 \text{ }^\circ\text{C}$ within all measurements necessary for the determination of the sound level of one set of tyres. In this case the regression analysis below shall be based on the uncorrected rolling sound levels $L_i(\vartheta_i)$.

There will be no temperature correction for class C3 tyres."

Annex 3 – Appendix 1

Part 1, item 6.1., amend to read:

"6.1. Snow tyre use in severe snow conditions (Yes/No)¹"

Part 2, item 2., amend to read:

"2. Test vehicle (make, model, year, modifications, etc.):
....."

Part 2, item 5.2., amend to read:

"5.2. Sound level according to paragraph 4.3. of Annex 3:
.....dB(A)"

Footnote 2, amend to read:

"² for classes C2 and C3 tyres, corresponding to the indication of the inflation pressure marked on the sidewall as required by paragraph 4.1. of this Regulation"

Annex 4,

Paragraph 2.1., amend to read:

"2.1. Residual voids content

The residual Voids Content (VC) of the test track paving mixture shall not exceed 8 per cent. For the measurement procedure, see paragraph 4.1. of this Annex."

Paragraph 4.1., amend to read:

"4.1. Measurement of the residual voids content

For the purpose of this measurement, cores have to be taken from the track in at least four different positions, which are equally distributed in the test area between lines AA and BB (see Figure 1). In order to avoid inhomogeneity and unevenness in the wheel tracks, cores should not be taken in wheel tracks themselves, but close to them. Two cores (minimum) should be taken close to the wheel tracks and one core (minimum) should be taken approximately midway between the wheel tracks and each microphone location.

If there is a suspicion that the condition of homogeneity is not met (see paragraph 2.4. above), cores shall be taken from more locations within the test area.

The residual voids content has to be determined for each core, then the average value from all cores shall be calculated and compared with the requirement of paragraph 2.1. of this Annex. In addition, no single core shall have a voids value, which is higher than 10 per cent.

The test surface constructor is reminded of the problem, which may arise when the test area is heated by pipes or electrical wires and cores shall be taken from this area. Such installations shall be carefully planned with respect to future core drilling locations. It is recommended to leave a few locations of size approximately 200 mm x 300 mm where there are no wires/pipes or where the latter are located deep enough in order not to be damaged by cores taken from the surface layer."

Annex 5

Title, amend to read:

"Annex 5

Test procedures for measuring the wet ~~grip index~~ adhesion of new tyres"

Part (A), title, amend to read:

"(A) — Class C1 tyres"

Paragraph 2., amend to read:

"2. Definitions

In addition to the definitions in paragraph 2. of the main body of this Regulation, for the purposes of measuring wet adhesion of class C1 tyres:"

Paragraphs 2.1. to 2.5, delete.

Paragraph 2.6., renumber as 2.1. and amend to read:

"2.1. "Reference tyre" or "reference tyre set" means a tyre or a tyre set of Standard Reference Test Tyres SRTT16."

Paragraph 2.7., renumber as 2.2.

Paragraph 2.8., renumber as 2.3. and amend to read:

"2.3. "Average braking force coefficient" (BFC) means, for the vehicle method, the ratio of the average deceleration in a braking test to the acceleration due to gravity (rounded to $9.81 \text{ m}\cdot\text{s}^{-2}$)."

Paragraphs 2.9. to 2.15., renumber as 2.4. to 2.10.

Paragraph 3.1.5., amend to read:

"3.1.5. The wetted frictional properties of the surface shall be measured using the SRTT16 either with the method described in paragraph 3.2.1. of this Annex in case the vehicle method (according to paragraph 4.1. below) is used, or with the method described in paragraph 3.2.2. in this Annex in case the trailer (or tyre test vehicle) method is used."

Paragraph 3.2.1., amend to read:

"3.2.1. Using the procedure described in paragraph 4.1. of this Annex, perform two braking tests of the reference tyre, each consisting of at least six (6) valid test runs in the same direction on aligned segments of the track. The braking tests shall cover the entire potential braking area, including where the texture depth was measured.

Evaluate the braking tests as described in paragraphs 4.1.6.1. and 4.1.6.2. of this Annex. If the coefficient of variation of one braking test CV_{BFC} exceeds 4 per cent, dismiss the results and repeat the braking tests.

For each braking test, the arithmetic mean \overline{BFC}_{ave} of the average braking force coefficients shall be corrected for effects of temperature as follows:

$$BFC_{ave,corr} = \overline{BFC}_{ave} + a \cdot (\vartheta - \vartheta_0)$$

where

ϑ is the wetted surface temperature in degrees Celsius,

$a = 0.002 \text{ }^\circ\text{C}^{-1}$ and $\vartheta_0 = 20 \text{ }^\circ\text{C}$.

For each braking test, the temperature-corrected average braking force coefficient ($BFC_{ave,corr}$) shall be not less than 0.57 and not greater than 0.79.

The arithmetic means of the temperature-corrected average braking force coefficients of the two braking tests shall not differ by more than 10 per cent of the average of the two values:

$$CVal(BFC_{ave,corr}) = 2 \cdot \left| \frac{BFC_{ave,corr,1} - BFC_{ave,corr,2}}{BFC_{ave,corr,1} + BFC_{ave,corr,2}} \right| \leq 10 \%$$

"

Paragraph 4., amend to read:

"4. Testing methods for measuring wet adhesion

For the calculation of the wet grip index (G) of a candidate tyre, the wet grip braking performance of the candidate tyre is compared to the wet grip braking performance of the reference tyre on a vehicle travelling straight ahead on a wet, paved surface. It is measured with one of the following methods:

- (a) Vehicle method consisting of testing a set of tyres mounted on an instrumented passenger car;
- (b) Testing method using a trailer towed by a vehicle or a tyre test vehicle, equipped with the test tyre(s)."

Paragraph 4.1.1., amend to read:

"4.1.1. Principle

The testing method covers a procedure for measuring the deceleration performance of class C1 tyres during braking, using an instrumented passenger car.

Starting with a defined initial speed, the brakes are applied hard enough on four wheels at the same time to activate the ABS. The average deceleration is calculated between two pre-defined speeds."

Paragraph 4.1.6.1., amend to read:

"4.1.6.1. Calculation of the average braking force coefficient

For each valid test run j , the average braking force coefficient $BFC_{ave,j}$ is calculated from the distance d_j covered between 80 km/h and 20 km/h as follows:

$$BFC_{ave,j} = \frac{v_i^2 - v_f^2}{2 \cdot d_j \cdot g}$$

where:

v_f is the final speed in m/s; $v_f = 20 \text{ km/h} = 5.556 \text{ m/s}$

v_i is the initial speed in m/s; $v_i = 80 \text{ km/h} = 22.222 \text{ m/s}$

d_j is the distance covered in test run j between v_i and v_f in metres;

g is the acceleration due to gravity = $9.81 \text{ m}\cdot\text{s}^{-2}$."

Paragraph 4.1.6.2., amend to read:

"4.1.6.2. Validation of results

The coefficient of variation CV_{BFC} is calculated as follows:

$$CV_{BFC} = 100\% \cdot \frac{\sigma_{BFC}}{\overline{BFC_{ave}}}$$

where

$\sigma_{BFC} = \sqrt{\frac{1}{N-1} \sum_{j=1}^N (BFC_{ave,j} - \overline{BFC_{ave}})^2}$ denotes the corrected sample standard deviation and

$\overline{BFC_{ave}}$ the arithmetic mean of the average braking force coefficients $BFC_{ave,j}$ of N test runs.

For the reference tyre:

(a) The coefficient of variation CV_{BFC} of the initial and the final braking test of the reference tyre within one test cycle shall be less than or equal to 4 per cent.

(b) The arithmetic means of the average braking force coefficients of the initial and the final braking test shall not differ by more than 5 per cent of the average of the two values:

$$CV_{val}(BFC_{ave}) = 100\% \cdot 2 \cdot \frac{|\overline{BFC_{ave}}(R_i) - \overline{BFC_{ave}}(R_f)|}{\overline{BFC_{ave}}(R_i) + \overline{BFC_{ave}}(R_f)} \leq 5\%$$

where

$\overline{BFC_{ave}}(R_i) / \overline{BFC_{ave}}(R_f)$ is the arithmetic mean of the average braking force coefficients in the initial/final braking test of the reference tyre within a test cycle.

- (c) The temperature-corrected average braking force coefficients ($BFC_{ave,corr}$, see paragraph 3.2.1. of this Annex) as calculated from the initial and from the final braking tests of the reference tyre within a test cycle shall be not less than 0.57 and not greater than 0.79.

If one or more of the above conditions is not met, the complete test cycle shall be performed again.

For the candidate tyres (T):

The coefficient of variation CV_{BFC} is calculated for each candidate tyre set. If one coefficient of variation is higher than 4 per cent, the data shall be discarded and the braking test repeated for that candidate tyre set."

Paragraph 4.1.6.3., amend to read:

"4.1.6.3. Calculation of adjusted average braking force coefficient

The average braking force coefficient of the reference tyre set used for the calculation of its braking force coefficient is adjusted according to the positioning of each candidate tyre set in a given test cycle.

This adjusted average braking force coefficient of the reference tyre $BFC_{adj}(R)$ is calculated in accordance with Table 1 where $\overline{BFC_{ave}}(R_i)$ is the arithmetic mean of the average braking force coefficients in the initial braking test of the reference tyre set (R_i) and $\overline{BFC_{ave}}(R_f)$ is the arithmetic mean of the average braking force coefficients in the final braking test of the same reference tyre set (R_f) within the test cycle.

Table 1

| If the number and the sequence of candidate tyre sets within one test cycle is: | and the candidate tyre set to be qualified within this test cycle is: | the corresponding adjusted average braking force coefficient of the reference tyre is calculated as follows: |
|---|---|--|
| 1 $R_i - T_1 - R_f$ | T_1 | $BFC_{adj}(R) = 1/2 \cdot [\overline{BFC_{ave}}(R_i) + \overline{BFC_{ave}}(R_f)]$ |
| 2 $R_i - T_1 - T_2 - R_f$ | T_1 | $BFC_{adj}(R) = 2/3 \cdot \overline{BFC_{ave}}(R_i) + 1/3 \cdot \overline{BFC_{ave}}(R_f)$ |
| | T_2 | $BFC_{adj}(R) = 1/3 \cdot \overline{BFC_{ave}}(R_i) + 2/3 \cdot \overline{BFC_{ave}}(R_f)$ |
| 3 $R_i - T_1 - T_2 - T_3 - R_f$ | T_1 | $BFC_{adj}(R) = 3/4 \cdot \overline{BFC_{ave}}(R_i) + 1/4 \cdot \overline{BFC_{ave}}(R_f)$ |
| | T_2 | $BFC_{adj}(R) = 1/2 \cdot [\overline{BFC_{ave}}(R_i) + \overline{BFC_{ave}}(R_f)]$ |
| | T_3 | $BFC_{adj}(R) = 1/4 \cdot \overline{BFC_{ave}}(R_i) + 3/4 \cdot \overline{BFC_{ave}}(R_f)$ |

Paragraph 4.1.6.4., amend to read:

"4.1.6.4. Calculation of the wet grip index of the candidate tyre

The wet grip index $G(T_n)$ of the candidate tyre T_n ($n = 1, 2$ or 3) is calculated as follows:

$$G(T_n) = K_{vehicle} \cdot \{\overline{BFC_{ave}}(T_n) - [a \cdot \Delta BFC(R) + b \cdot \Delta\theta + c \cdot (\Delta\theta)^2 + d \cdot \Delta MTD]\}$$

where:

$\overline{BFC_{ave}}(T_n)$ is the arithmetic mean of the average braking force coefficients of the candidate tyre T_n within a braking test;

$$\Delta BFC(R) = BFC_{adj}(R) - BFC(R_0)$$

$BFC_{adj}(R)$ is the adjusted average braking force coefficient in accordance with Table 1;

$BFC(R_0)$ = 0.68 is fixed as the braking force coefficient for the reference tyre in the reference conditions;

$$\Delta\vartheta = \vartheta - \vartheta_0$$

ϑ is the measured wet surface temperature in degrees Celsius when the candidate tyre T_n is tested;

ϑ_0 is the wetted surface reference temperature for the candidate tyre according to its category of use as listed in Table 2;

$$\Delta MTD = MTD - MTD_0$$

MTD is the measured macro texture depth in mm of the track (see paragraph 3.1.4. of this Annex);

$MTD_0 = 0.8$ mm is the macro texture depth of the reference track;

$K_{\text{vehicle}} = 1.87$ is a factor to grant consistency between previous calculation of the wet grip index and this one, and to ensure convergence between vehicle and trailer method and

coefficients a , b , c and d are given in Table 2.

Table 2

| Category of use | ϑ_0 (°C) | a | b (°C ⁻¹) | c (°C ⁻²) | d (mm ⁻¹) |
|---|-----------------------|----------|----------------------------|----------------------------|----------------------------|
| Normal tyre | 20 | +0.99382 | +0.00269 | -0.00028 | -0.02472 |
| Snow tyre | 15 | +0.92654 | -0.00121 | -0.00007 | -0.04279 |
| Snow tyre for use in severe snow conditions | 10 | +0.72029 | -0.00539 | +0.00022 | -0.03037 |
| Special-use tyre | not defined | | | | |

"

Paragraph 4.2.4.2., amend to read:

"4.2.4.2. For "self-watering" systems, the tow vehicle and trailer or the tyre test vehicle may be optionally equipped with a pavement-wetting system, less the storage tank, which, in the case of the trailer, is mounted on the tow vehicle. The water being applied to the pavement ahead of the test tyres shall be supplied by a nozzle suitably designed to ensure that the water layer encountered by the test tyre has a uniform cross section at the test speed with a minimum splash and overspray.

The nozzle configuration and position shall ensure that the water jets are directed towards the test tyre and pointed towards the pavement at an angle of 20° to 30°.

The water shall strike the pavement 250 mm to 450 mm ahead of the centre of tyre contact. The nozzle shall be located 25 mm above the pavement or at the minimum height required to clear obstacles which the tester is expected to encounter, but in no case more than 100 mm above the pavement.

The water layer shall be at least 25 mm wider than the test tyre tread and applied so the tyre is centrally located between the edges. Water delivery rate shall ensure a water depth of (1.0 ± 0.5) mm and shall be consistent throughout the test to within ±10 per cent. The volume of water per unit of wetted width shall be directly proportional to the test speed. The quantity of water applied at 65 km/h shall be 18 l/s per metre of width of wetted surface in case of a water depth of 1.0 mm."

Paragraph 4.2.7.1.4., amend to read:

"4.2.7.1.4. The brakes shall be activated within an area of six (6) metres in the longitudinal direction and 0.5 metres in the transversal direction of a measurement point of the wetted frictional properties of the surface and sand depth in accordance with paragraphs 3.1.4. and 3.1.5. above. The test shall be run in the same direction as in paragraph 3.2.2. of this Annex. The rate of braking application shall be such that the time interval between initial application of force and peak longitudinal force is in the range 0.2 s to 0.5 s."

Paragraph 4.2.8.2., amend to read:

"4.2.8.2. Validation of results

The μ_{peak} coefficient of variation CV_{μ} is calculated as follows:

$$CV_{\mu} = 100\% \cdot \frac{\sigma_{\mu}}{\overline{\mu_{\text{peak}}}}$$

where

$\sigma_{\mu} = \sqrt{\frac{1}{N-1} \sum_{j=1}^N (\mu_{\text{peak},j} - \overline{\mu_{\text{peak}}})^2}$ denotes the corrected sample standard deviation and

$\overline{\mu_{\text{peak}}}$ the arithmetic mean of the peak braking force coefficients ($\mu_{\text{peak},j}$) of N test runs.

For the reference tyre (R):

- (a) The coefficients of variation CV_{μ} of the initial and the final braking tests of the reference tyre within one test cycle shall be less than or equal to 4 per cent;
- (b) The arithmetic mean of the peak braking force coefficients of initial and the final braking test of the reference tyre within one test cycle shall not differ by more than 5 per cent of the average of the two values:

$$CV_{\text{val}}(\mu_{\text{peak}}) = 100\% \cdot 2 \cdot \frac{|\overline{\mu_{\text{peak}}}(\text{R}_i) - \overline{\mu_{\text{peak}}}(\text{R}_f)|}{\overline{\mu_{\text{peak}}}(\text{R}_i) + \overline{\mu_{\text{peak}}}(\text{R}_f)} \leq 5\%$$

where

$\overline{\mu_{\text{peak}}}(\text{R}_i)$ and $\overline{\mu_{\text{peak}}}(\text{R}_f)$ are the arithmetic means of the peak braking force coefficients respectively in the initial and final braking tests of the reference tyre within a test cycle;

- (c) The temperature-corrected average peak braking force coefficients ($\mu_{\text{peak,corr}}$, see paragraph 3.2.2. of this Annex) as calculated from the initial and from the final braking test of the reference tyre within a test cycle shall be not less than 0.65 and not greater than 0.90.

If one or more of the above conditions is not met, the complete test cycle shall be performed again.

For the candidate tyre(s) (T_n):

The coefficient of variation of the peak braking force coefficient CV_{μ} is calculated for each candidate tyre. If one coefficient of variation is greater than 4 per cent, the data shall be discarded and the braking test repeated for this candidate tyre."

Part (B), Heading, amend to read:

"(B) – Classes C2 and C3 tyres

Paragraph 1.1.1., amend to read:

"1.1.1. Standard Reference Test Tyre method

This method uses the SRTT16.

Using the procedure described in paragraph 4.2. of part (A) of this Annex, perform in the same area where the average macro texture depth was measured one braking test of the reference tyre, consisting of at least six (6) valid test runs in the same direction.

Evaluate the braking test as described in paragraphs 4.2.8.1. and 4.2.8.2. of part (A) of this Annex. If the coefficient of variation CV_μ exceeds 4 per cent, dismiss the results and repeat the braking test.

The arithmetic mean ($\overline{\mu_{\text{peak}}}$) of the measured peak braking force coefficients shall be corrected for the effects of temperature as follows:

$$\mu_{\text{peak,corr}} = \overline{\mu_{\text{peak}}} + a \cdot (\vartheta - \vartheta_0)$$

where

ϑ is the wetted track surface temperature in degrees Celsius,

$a = 0.002 \text{ } ^\circ\text{C}^{-1}$ and $\vartheta_0 = 20 \text{ } ^\circ\text{C}$.

The temperature corrected average peak braking force coefficient ($\mu_{\text{peak,corr}}$) shall be not less than 0.65 and not greater than 0.90.

The test shall be conducted using the lanes and length of the track to be used for the wet adhesion measurement.

For the trailer method, testing is run in such a way that braking occurs within 10 metres distance of where the surface was characterized."

Paragraph 1.4., amend to read:

"1.4. In order to cover the range of the tyre sizes fitting the commercial vehicles, the Standard Reference Test Tyres (SRTT) shall be used to measure the relative wet index as shown in the following table:

| | |
|--|---|
| <i>For class C3 tyres</i> | |
| Narrow family $S_{\text{Nominal}} < 285 \text{ mm}$ | Wide family $S_{\text{Nominal}} \geq 285 \text{ mm}$ |
| SRTT19.5 | SRTT22.5 |
| <i>For class C2 tyres</i> | |
| SRTT16C | |
| $S_{\text{Nominal}} = \text{Tyre nominal section width}$ | |

"

Paragraph 2., amend to read:

"2. Test procedure

The comparative wet adhesion level shall be established using either:

- (a) A trailer or special purpose tyre evaluation vehicle; or
- (b) A standard production vehicle (M_2 , M_3 , N_1 , N_2 or N_3 , category) as defined in the Consolidated Resolution on the Construction of Vehicles (R.E.3.)."

Paragraph 2.1.1.4., amend to read:

"2.1.1.4. In the case a track wetting system is incorporated:

The system shall be able to deliver the water such that the tyre and track surface in front of the tyre are wetted before the start of braking and throughout the duration of the test. The apparatus may be optionally equipped with a pavement-wetting system, less the storage tank, which, in the case of the trailer, is mounted on the tow vehicle. The water being applied to the pavement ahead

of the test tyres shall be supplied by a nozzle suitably designed to ensure that the water layer encountered by the test tyre has a uniform cross section at the test speed with a minimum splash and overspray.

The nozzle configuration and position shall ensure that the water jets shall be directed toward the test tyre and pointed toward the pavement at an angle of 15 to 30°. The water shall strike the pavement 0.25 to 0.5 m ahead of the centre of tyre contact. The nozzle shall be located 100 mm above the pavement or the minimum height required to clear obstacles which the tester is expected to encounter, but in no case more than 200 mm above the pavement. The water layer shall be at least 25 mm wider than the test tyre tread and applied so the tyre is centrally located between the edges. The volume of water per unit of wetted width shall be directly proportional to the test speed. The quantity of water applied at 50 km/h shall be 14 l/s per metre of the width of the wetted surface. The nominal values of rate of water application shall be maintained within ±10 per cent."

Paragraph 2.1.2.14., amend to read:

"2.1.2.14. The wet grip index (G) shall be calculated as:

$$\text{Wet grip index (G)} = \mu_{\text{peak,ave}} (T) / \mu_{\text{peak,ave}} (R)$$

It represents the relative wet grip index for braking performance of the candidate tyre (T) compared to the reference tyre (R)."

Paragraph 2.2.2.2., amend to read:

"2.2.2.2. Vehicle equipment

The rear axle may be indifferently fitted with 2 or 4 tyres.

For the reference tyre testing, both axles are fitted with reference tyres. (A total of 4 or 6 reference tyres depending on the choice above mentioned).

For the candidate tyre testing, 3 fitting configurations are possible:

- (a) "Configuration 1": candidate tyres on front and rear axles: it is the standard configuration that should be used every time it is possible.
- (b) "Configuration 2": candidate on front axle and reference tyre or control tyre on rear axle: allowed in such cases where fitting the candidate tyre on the rear position is not possible.
- (c) "Configuration 3": candidate on rear axle and reference tyre or control tyre on front axle: permitted in such cases where fitting the candidate tyre on the front position is not possible."

Paragraph 2.2.2.6.1., amend to read:

"2.2.2.6.1. First, mount the set of reference tyres on the vehicle.

The vehicle accelerates in the starting zone up to 65 ± 2 km/h.

Activation of the brakes on the track is made always at the same place with a tolerance of 5 metres in longitudinal and 0.5 metres in transverse."

Paragraph 2.2.2.7.4., amend to read:

"2.2.2.7.4. Calculation of braking force coefficient, BFC

BFC(R) and BFC(T) are calculated according to Table 6:

Table 6

| <i>Tested tyre</i> | <i>Braking force coefficient is</i> |
|--------------------|-------------------------------------|
| Reference tyre | BFC(R) = Ra/g |
| Candidate tyre | BFC(T) = Ta/g |

g is the acceleration due to gravity (rounded to $9.81 \text{ m}\cdot\text{s}^{-2}$).

T_a ($a = 1, 2, \text{ etc.}$) is the average of the AD values for a test of a candidate tyre."

Paragraph 2.2.2.7.5., amend to read:

"2.2.2.7.5. Calculation of the relative wet grip index of the tyre

The wet grip index represents the relative performance of the candidate tyre compared to the reference tyre. The way to obtain it depends on the test configuration as defined in paragraph 2.2.2.2. of this Annex. The wet grip index G of the tyre is calculated as reported into Table 7:

Table 7

| | |
|--|--|
| Configuration C1: candidate tyres on both axles | $G = \frac{BFC(T)}{BFC(R)}$ |
| Configuration C2: candidate tyres on front axle and reference tyres on rear axle | $G = \frac{BFC(T) \cdot [a + b + h \cdot BFC(R)] - a \cdot BFC(R)}{BFC(R) \cdot [b + h \cdot BFC(T)]}$ |
| Configuration C3: reference tyres on front axle and candidate tyres on rear axle | $G = \frac{BFC(T) \cdot [-a - b + h \cdot BFC(R)] + b \cdot BFC(R)}{BFC(R) \cdot [-a + h \cdot BFC(T)]}$ |

Where (see also Figure 1):

- cog: centre of gravity of the loaded vehicle
 - m : mass (in kilograms) of the loaded vehicle
 - a : horizontal distance between front axle and centre of gravity of the loaded vehicle (m)
 - b : horizontal distance between rear axle and centre of gravity of the loaded vehicle
 - h : vertical distance between ground level and centre of gravity of the loaded vehicle (m).
- N.B.* When h is not precisely known, these worst case values shall apply: 1.2 m for configuration C2, and 1.5 m for configuration C3
- γ : loaded vehicle acceleration [$\text{m}\cdot\text{s}^{-2}$]
 - g : acceleration due to the gravity [$\text{m}\cdot\text{s}^{-2}$]
 - X_1 : longitudinal (X-direction) reaction of the front tyre on the road
 - X_2 : longitudinal (X-direction) reaction of the rear tyre on the road
 - Z_1 : normal (Z-direction) reaction of the front tyre on the road
 - Z_2 : normal (Z-direction) reaction of the rear tyre on the road

Figure 1
 Nomenclature explanation related to grip index of the tyre

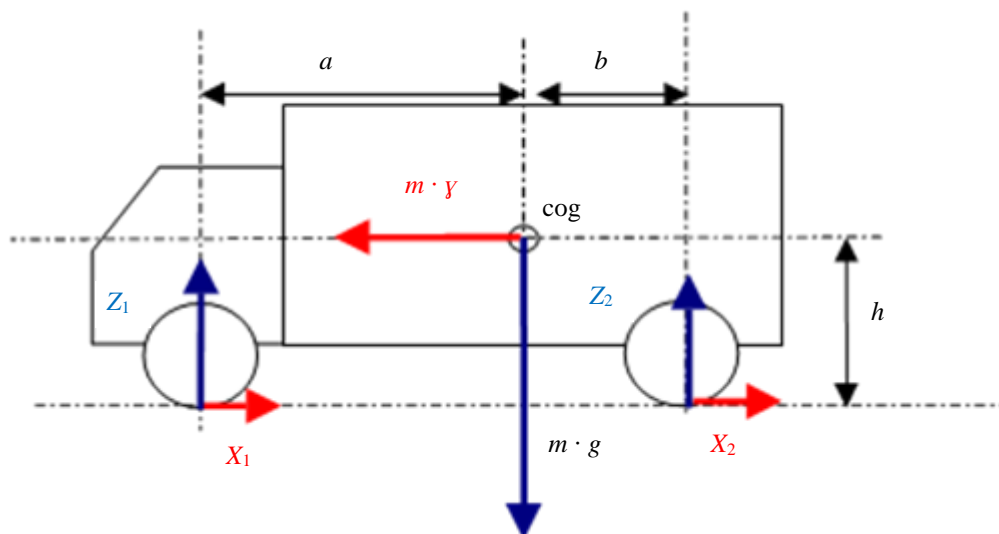

"

Paragraph 2.2.2.8., amend to read:

"2.2.2.8. Wet adhesion comparison between a candidate tyre and a reference tyre using a control tyre

When the candidate tyre size is significantly different from the reference tyre, a direct comparison on the same vehicle may be not possible. This approach uses an intermediate tyre, hereinafter called the control tyre."

Annex 5 – Appendix, Example 1, amend to read:

"...

| No. | 1 | 2 | 3 | 4 | 5 |
|--|---------|---|---|---|---------|
| Brand | | | | | |
| Pattern/trade description | SRTT... | | | | SRTT... |
| Size | | | | | |
| Service description | | | | | |
| Reference (test) inflation pressure ⁽¹⁾ (kPa) | | | | | |
| Tyre identification | | | | | |
| M+S marking (Y/N) | | | | | |
| 3PMSF marking (Y/N) | | | | | |
| Rim | | | | | |
| Load (kg) | | | | | |
| Pressure (kPa) | | | | | |
| μ _p e a k | 1 | | | | |
| | 2 | | | | |
| | 3 | | | | |
| | 4 | | | | |
| | 5 | | | | |

| | | | | | |
|--|---|---|---|---|---|
| 6 | | | | | |
| 7 | | | | | |
| 8 | | | | | |
| $\overline{\mu_{peak}}$ | | | | | |
| Standard deviation, σ_{μ} | | | | | |
| $CV_{\mu} \leq 4\%$ ⁽²⁾ | | | | | |
| $CVal(\mu_{peak}) \leq 5\%$ ⁽³⁾ | X | X | X | X | X |
| $\mu_{peak,corr}(R)$ | X | X | X | X | X |
| $\mu_{peak,adj}(R)$ | X | X | X | X | X |
| Wet grip index | X | X | X | X | X |
| Wetted surface temp. (°C) | | | | | |
| Ambient temp. (°C) | | | | | |
| Remarks | | | | | |

⁽¹⁾ for classes C2 and C3 tyres, corresponding to the indication of the inflation pressure marked on the sidewall as required by paragraph 4.1. of this Regulation

⁽²⁾ For classes C2 and C3 tyres, the limit is 5 %.

⁽³⁾ For classes C2 and C3 tyres, $CVal(\mu_{peak})$ is not defined nor applied."

Annex 5 – Appendix, Example 2, amend to read:

"Example 2: Test report of wet grip index using vehicle method

| | | | | | |
|----------------------------|--|-------------------|--|--|--|
| Test report number: | | Test date: | | | |
|----------------------------|--|-------------------|--|--|--|

| | | | | | |
|--------------------------|--|----------------------------|----------|-----------------------|--------------|
| Track: | | Minimum: | Maximum: | Vehicle | |
| Texture depth (mm): | | Wetted surface temp. (°C): | | Brand: | |
| $BFC_{ave,corr,1}$: | | Ambient temp (°C): | | Model: | |
| $BFC_{ave,corr,2}$: | | | | Type: | |
| $CVal(BFC_{ave,corr})$: | | | | Year of registration: | |
| Water depth (mm): | | | | Maximum axle load: | Front Rear |

| | | | |
|-----------------------|--|---------------------|--|
| Initial speed (km/h): | | Final speed (km/h): | |
|-----------------------|--|---------------------|--|

| No. | 1 | 2 | 3 | 4 | 5 | | | | | |
|--|-----------------------------|------------------------|-----------------------------|------------------------|-----------------------------|------------------------|-----------------------------|------------------------|-----------------------------|------------------------|
| Brand | | | | | | | | | | |
| Pattern/trade description | SRTT... | | | | SRTT... | | | | | |
| Size | | | | | | | | | | |
| Service description | | | | | | | | | | |
| Reference (test) inflation pressure ⁽¹⁾ (kPa) | | | | | | | | | | |
| Tyre identification | | | | | | | | | | |
| M+S marking (Y/N) | | | | | | | | | | |
| 3PMSF marking (Y/N) | | | | | | | | | | |
| Rim | | | | | | | | | | |
| Front axle pressure (kPa) | left: right: | left: right: | left: right: | left: right: | left: right: | | | | | |
| Rear axle pressure (kPa) | left: right: | left: right: | left: right: | left: right: | left: right: | | | | | |
| Front axle load (kg) | left: right: | left: right: | left: right: | left: right: | left: right: | | | | | |
| Rear axle load (kg) | left: right: | left: right: | left: right: | left: right: | left: right: | | | | | |
| | <i>Braking distance (m)</i> | <i>BFC_i</i> | <i>Braking distance (m)</i> | <i>BFC_i</i> | <i>Braking distance (m)</i> | <i>BFC_i</i> | <i>Braking distance (m)</i> | <i>BFC_i</i> | <i>Braking distance (m)</i> | <i>BFC_i</i> |
| Measurement | 1 | | | | | | | | | |

| | | | | | | | | | | | |
|---|----|--|--|--|--|--|--|--|--|--|--|
| | 2 | | | | | | | | | | |
| | 3 | | | | | | | | | | |
| | 4 | | | | | | | | | | |
| | 5 | | | | | | | | | | |
| | 6 | | | | | | | | | | |
| | 7 | | | | | | | | | | |
| | 8 | | | | | | | | | | |
| | 9 | | | | | | | | | | |
| | 10 | | | | | | | | | | |
| \overline{BFC}_{ave} | | | | | | | | | | | |
| Standard deviation, σ_{BFC} | | | | | | | | | | | |
| $CV_{BFC} \leq 4\%$ ⁽²⁾ | | | | | | | | | | | |
| $CVal(BFC_{ave}) \leq 5\%$ ⁽³⁾ | | | | | | | | | | | |
| $BFC_{ave,corr}(R)$ | | | | | | | | | | | |
| $BFC_{adj}(R)$ | | | | | | | | | | | |
| Wet grip index | | | | | | | | | | | |
| Wetted surface temp. (°C) | | | | | | | | | | | |
| Ambient temp. (°C) | | | | | | | | | | | |
| Remarks | | | | | | | | | | | |

⁽¹⁾ for classes C2 and C3 tyres, corresponding to the indication of the inflation pressure marked on the sidewall as required by paragraph 4.1. of this Regulation.

⁽²⁾ For classes C2 and C3 tyres, the limit is 3 %.

⁽³⁾ For classes C2 and C3 tyres, $CVal(BFC_{ave})$ is not defined nor applied."

Annex 6,

Paragraph 2.1.1., amend to read:

"2.1.1. Diameter

The test dynamometer shall have a cylindrical flywheel (drum) with a diameter of at least 1.7 m.

The F_r and C_r values shall be expressed relative to a drum diameter of 2.0 m. If drum diameter different than 2.0 m is used, a correlation adjustment shall be made following the method in paragraph 6.3. of this Annex."

Paragraph 2.2., amend to read:

"2.2. Measuring rim

The tyre shall be mounted on a steel or light alloy measuring rim, as follows:

- (a) For class C1 tyres, the width of the rim shall be as defined in ISO 4000-1:2015,
- (b) For classes C2 and C3 tyres, the width of the rim shall be as defined in ISO 4209 1:2001.

In cases where the width is not defined in the above-mentioned ISO Standards, the rim width as defined by one of the standards organizations as specified in Appendix 4 may be used."

Paragraph 2.4.2., amend to read:

"2.4.2. Alternative conditions

If the test ambient temperature is different from the reference ambient temperature, the rolling resistance measurement shall be corrected to the reference ambient temperature in accordance with paragraph 6.2. of this Annex."

Table 1., amend to read:

"Table 1
Test Speeds (in km/h)

| Tyre class | C1 | C2 and C3 | C3 | |
|-----------------------|-----|-----------|------------------------|-------------------------|
| Load index | All | LI ≤ 121 | LI > 121 | |
| Speed category symbol | All | All | J (100 km/h) and lower | K (110 km/h) and higher |
| Test speed (km/h) | 80 | 80 | 60 | 80 |

"

Table 2, amend to read:

Table 2
Test loads and inflation pressures

| Tyre class | C1 | | C2, C3 |
|---|---------------|--------------------------|--|
| | Standard load | Reinforced or extra load | |
| Load - % of maximum load capacity as indicated by the load capacity index | 80 | 80 | 85 (Refer to single application) |
| Inflation pressure kPa | 210 | 250 | Test inflation pressure corresponding to the indication of the inflation pressure marked on the sidewall as required by paragraph 4.1. of this Regulation. |

Note: The inflation pressure shall be capped with the accuracy specified in paragraph 4. of Appendix 1 to this Annex.

"

Paragraph 3.5., amend to read:

"3.5. Duration and speed.

When the deceleration method is selected, the following requirements apply:

- (a) The deceleration j shall be determined in differential $d\omega/dt$ or discrete $\Delta\omega/\Delta t$ form, where ω is angular velocity, t – time;

If the differential form $d\omega/dt$ is used, then the recommendations of Appendix 5 to this annex are to be applied;

- (b) For duration Δt , the time increments shall not exceed 0.5 s;
(c) Any variation of the test drum speed shall not exceed 1 km/h within one time increment."

Paragraph 4.2., amend to read:

"4.2. Thermal conditioning

The inflated tyre shall be placed in the thermal environment of the test location for a minimum of:

- (a) 3 hours for class C1 tyres;
(b) 6 hours for classes C2 and C3 tyres."

Table 3., amend to read:

"Table 3
Warm up durations

| Tyre class | C1 | C2 and C3 | |
|----------------------|---------|---------------|----------------------|
| | | $LI \leq 121$ | $LI > 121$ |
| Nominal rim diameter | All | All | < 22.5 ≥ 22.5 |
| Warm up duration | 30 min. | 50 min. | 150 min. 180 min. |

"

Paragraph 4.5.(j), amend to read:

"(j) Tyre size, manufacturer, type, identity number (if one exists), speed category symbol, load index, DOT number (Department of Transportation)."

Paragraph 4.6.1.(a)(ii), amend to read:

"(ii) Class C2 tyres: recommended value of 150 N; not to exceed 200 N for machines designed for class C1 tyre measurement or 500 N for machine designed for classes C2 and C3 tyres;"

Paragraph 4.7., amend to read:

"4.7. Allowance for machines exceeding σ_m criterion

The steps described in paragraphs 4.3. to 4.5. above shall be carried out once only, if the measurement standard deviation determined in accordance with paragraph 6.5. below is:

- (a) Not greater than 0.075 N/kN for classes C1 and C2 tyres;
- (b) Not greater than 0.06 N/kN for class C3 tyres.

If the measurement standard deviation exceeds this criterion, the measurement process will be repeated n times as described in paragraph 6.5. below. The rolling resistance value reported shall be the average of the n measurements."

Paragraph 5.1.2., amend to read:

"5.1.2. Force method at tyre spindle

Calculate: $F_{pl} = F_t (1 + r_L/R)$

Where:

- F_t is the tyre spindle force in newton (see paragraph 4.6.1. above),
- r_L is the distance from the tyre axis to the drum outer surface under steady state conditions, in metres,
- R is the test drum radius, in metres."

Paragraph 5.1.3., amend to read:

"5.1.3. Torque method at drum axis

Calculate: $F_{pl} = T_t/R$

Where:

- T_t is the input torque in newton metres, as determined in paragraph 4.6.1,
- R is the test drum radius, in metres."

Paragraph 5.1.4., amend to read:

"5.1.4. Power method at drum axis

Calculate:
$$F_{pl} = \frac{3,6V \times A}{U_n}$$

Where:

- V is the electrical potential applied to the machine drive, in volts,
A is the electric current drawn by the machine drive, in amperes,
U_n is the test drum speed, in kilometres per hour."

Paragraph 5.1.5., amend to read:

"5.1.5. Deceleration method

Calculate the parasitic losses F_{pl}, in newtons.

$$F_{pl} = \frac{I_D}{R} \left(\frac{\Delta\omega_{D0}}{\Delta t_0} \right) + \frac{I_T}{R_r} \left(\frac{\Delta\omega_{T0}}{\Delta_0} \right)$$

Where:

- I_D is the test drum inertia in rotation, in kilogram metres squared,
R is the test drum surface radius, in metres,
Δω_{D0} is the test drum angular speed increment, drum without tyre, in radians per second,
Δt₀ is the time increment chosen for the measurement of the parasitic losses without tyre, in seconds,
I_T is the spindle, tyre and wheel inertia in rotation, in kilogram metres squared,
R_r is the tyre rolling radius, in metres,
Δω_{T0} is the tyre angular speed increment, unloaded tyre, in radians per second.

or

$$F_{pl} = \frac{I_D}{R} j_{D0} + \frac{I_T}{R_r} j_{T0}$$

Where:

- I_D is the test drum inertia in rotation, in kilogram metres squared,
R is the test drum surface radius, in metres,
j_{D0} is the deceleration of the test drum, without tyre, in radians per second squared,
I_T is the spindle, tyre and wheel inertia in rotation, in kilogram metres squared,
R_r is the tyre rolling radius, in metres,
j_{T0} is the deceleration of unloaded tyre, in radians per second squared."

Paragraph 5.2.2., amend to read:

"5.2.2. Force method at tyre spindle

The rolling resistance Fr, in newtons, is calculated using the equation

$$F_r = F_t [1 + (r_l/R)] - F_{pl}$$

Where:

- F_t is the tyre spindle force in newtons,

| | |
|----------|--|
| F_{pl} | represents the parasitic losses as calculated in paragraph 5.1.2. above, |
| r_L | is the distance from the tyre axis to the drum outer surface under steady-state conditions, in metres, |
| R | is the test drum radius, in metres." |

Paragraph 5.2.3., amend to read:

"5.2.3. Torque method at drum axis

The rolling resistance F_r , in newtons, is calculated with the equation

$$F_r = \frac{T_t}{R} - F_{pl}$$

Where:

| | |
|----------|--|
| T_t | is the input torque, in newton metres, |
| F_{pl} | represents the parasitic losses as calculated in paragraph 5.1.3. above, |
| R | is the test drum radius, in metres." |

Paragraph 5.2.4., amend to read:

"5.2.4. Power method at drum axis

The rolling resistance F_r , in newtons, is calculated with the equation:

$$F_r = \frac{3,6V \times A}{U_n} - F_{pl}$$

Where:

| | | |
|----------|---|---|
| V | = | is the electrical potential applied to the machine drive, in volts, |
| A | = | is the electric current drawn by the machine drive, in amperes, |
| U_n | = | is the test drum speed, in kilometres per hour, |
| F_{pl} | = | represents the parasitic losses as calculated in paragraph 5.1.4. above." |

Paragraph 5.2.5., amend to read:

"5.2.5. Deceleration method

The rolling resistance F_r , in newtons, is calculated using the equation:

$$F_r = \frac{I_D}{R} \left(\frac{\Delta\omega_v}{\Delta t_v} \right) + \frac{R \times I_T}{R_r^2} \left(\frac{\Delta\omega_v}{\Delta t_v} \right) - F_{pl}$$

Where:

| | |
|------------------|---|
| I_D | is the test drum inertia in rotation, in kilogram metres squared, |
| R | is the test drum surface radius, in metres, |
| F_{pl} | represents the parasitic losses as calculated in paragraph 5.1.5. above, |
| Δt_v | is the time increment chosen for measurement, in seconds, |
| $\Delta\omega_v$ | is the test drum angular speed increment, without tyre, in radians per second, |
| I_T | is the spindle, tyre and wheel inertia in rotation, in kilogram metres squared, |
| R_r | is the tyre rolling radius, in metres, |

F_r is the rolling resistance, in newtons.

or

$$F_r = \frac{I_D}{R} j_v + \frac{R \times I_T}{R_r^2} j_v - F_{pl}$$

Where:

I_D is the test drum inertia in rotation, in kilogram metres squared,

R is the test drum surface radius, in metres,

F_{pl} represents the parasitic losses as calculated in paragraph 5.1.5. above,

j_v is the deceleration of the test drum, in radians per second squared,

I_T is the spindle, tyre and wheel inertia in rotation, in kilogram metres squared,

R_r is the tyre rolling radius, in metres,

F_r is the rolling resistance, in newtons."

Paragraph 6.2., amend to read:

"6.2. Temperature correction

If measurements at temperatures other than 25 °C are unavoidable (only temperatures not less than 20 °C or more than 30 °C are acceptable), then a correction for temperature shall be made using the following equation, with:

F_{r25} is the rolling resistance at 25 °C, in newtons:

$$F_{r25} = F_r [1 + K(t_{amb} - 25)]$$

Where:

F_r is the rolling resistance, in newtons,

t_{amb} is the ambient temperature, in degrees Celsius,

K is equal to:

0.008 for class C1 tyres

0.010 for classes C2 and C3 tyres with a load index equal or lower than 121

0.006 for class C3 tyres with a load index greater than 121"

Paragraph 6.3., amend to read:

"6.3. Drum diameter correction

Test results obtained from different drum diameters shall be compared by using the following theoretical formula:

$$F_{r02} \cong KF_{r01}$$

With:

$$K = \sqrt{\frac{(R_1/R_2)(R_2 + r_T)}{(R_1 + r_T)}}$$

Where:

R_1 is the radius of drum 1, in metres,

R_2 is the radius of drum 2, in metres,

| | |
|-----------|--|
| r_T | is one-half of the nominal design tyre diameter, in metres, |
| F_{r01} | is the rolling resistance value measured on drum 1, in newtons, |
| F_{r02} | is the rolling resistance value measured on drum 2, in newtons." |

Paragraph 6.5., amend to read:

"6.5. The laboratory shall ensure that, based on a minimum of three measurements, the machine maintains the following values of σ_m , as measured on a single tyre:

$\sigma_m \leq 0.075$ N/kN for tyres of classes C1 and C2

$\sigma_m \leq 0.06$ N/kN for tyres of class C3

If the above requirement for σ_m is not met, the following formula shall be applied to determine the minimum number of measurements n (rounded to the immediate superior integer value) that are required by the machine to qualify for conformance with this Regulation.

$$n = (\sigma_m / x)^2$$

Where:

$x = 0.075$ N/kN for tyres of classes C1 and C2

$x = 0.06$ N/kN for tyres of class C3

If a tyre needs to be measured several times, the tyre/wheel assembly shall be removed from the machine between the successive measurements.

If the removal/refitting operation duration is less than 10 minutes, the warm-up durations indicated in paragraph 4.3. above may be reduced to:

- (a) 10 minutes for tyres of class C1;
- (b) 20 minutes for tyres of class C2;
- (c) 30 minutes for tyres of class C3."

Annex 6 - Appendix 1

Paragraph 2.1., amend to read:

"2.1. Width

For passenger car tyre rims (class C1 tyres), the test rim width shall be the same as the measuring rim determined in ISO 4000-1: 2010, clause 6.2.2.

For truck and bus tyres (classes C2 and C3), the rim width shall be the same as the measuring rim determined in ISO 4209-1:2001, clause 5.1.3.

In cases where the width is not defined in the above-mentioned ISO Standards, the rim width as defined by one of the standards organizations as specified in Appendix 4 to Annex 6 may be used."

Paragraph 2.2., amend to read:

"2.2. Run-out

In case vehicle rims are used, the run-out shall meet the following criteria:

(i) for class C1 tyres, class C2 tyres and for class C3 tyres with $LI \leq 121$:

- (a) Maximum radial run-out: 0.5 mm;
- (b) Maximum lateral run-out: 0.5 mm;

(ii) for class C3 tyres with $LI \geq 122$:

- (a) Maximum radial run-out: 2.0 mm,
- (b) Maximum lateral run-out: 2.0 mm."

Paragraph 4. (a), amend to read:

"(a) Tyre loading:

- (i) For class C1 tyres, class C2 tyres and for class C3 tyres with $LI \leq 121$: ± 20 N or ± 0.5 per cent, whichever is greater;
- (ii) For class C3 tyres with $LI \geq 122$: ± 45 N or ± 0.5 per cent whichever is greater;"

Paragraph 5., amend to read:

"5. Instrumentation accuracy

The instrumentation used for readout and recording of test data shall be accurate within the tolerances stated below:

| <i>Parameter</i> | <i>class C1 tyres, class C2 tyres and class C3 tyres with $LI \leq 121$</i> | <i>class C3 tyres with $LI \geq 122$</i> |
|--------------------|--|---|
| Tyre load | ± 10 N or ± 0.5 % ^(a) | ± 30 N or ± 0.5 % ^(a) |
| Inflation pressure | ± 1 kPa | ± 1.5 kPa |
| Spindle force | ± 0.5 N or ± 0.5 % ^(a) | ± 1.0 N or ± 0.5 % ^(a) |
| Torque input | ± 0.5 Nm or ± 0.5 % ^(a) | ± 1.0 Nm or ± 0.5 % ^(a) |
| Distance | ± 1 mm | ± 1 mm |
| Electrical power | ± 10 W | ± 20 W |
| Temperature | ± 0.2 °C | |
| Surface speed | ± 0.1 km/h | |
| Time | ± 0.01 s - ± 0.1 % - ± 10 s ^(b) | |
| Angular velocity | ± 0.1 % | |

^(a) Whichever is greater.

^(b) ± 0.01 s for the time increments specified in Annex 6, paragraph 3.5.(b) for the data acquisition in the deceleration method in $\Delta\omega/\Delta t$ form

± 0.1 per cent for the time increments specified in Annex 6, paragraph 3.5.(a) for the data acquisition in the deceleration method in $d\omega/dt$ form

± 10 sec for the other time durations specified in Annex 6."

Paragraph 6., amend to read:

"6. Compensation for load/spindle force interaction and load misalignment for the force method only

Compensation of both load/spindle force interaction ("cross talk") and load misalignment may be achieved either by recording the spindle force for both forward and reverse tyre rotation or by dynamic machine calibration. If spindle force is recorded for forward and reverse directions (at each test condition), compensation is achieved by subtracting the "reverse" value from the "forward" value and dividing the result by two. If dynamic machine calibration is intended, the compensation terms may be easily incorporated in the data reduction.

In cases where reverse tyre rotation immediately follows the completion of the forward tyre rotation, a warm-up time for reverse tyre rotation shall be at least 10 minutes for class C1 tyres and 30 minutes for all other tyre types."

Annex 6 - Appendix 3

Part 1,

Item 6.1., amend to read:

"6.1. Snow tyre for use in severe snow conditions (Yes/No)²"

Footnotes (1) and (2), amend to read:

"⁽¹⁾ for classes C2 and C3 tyres, corresponding to the indication of the inflation pressure marked on the sidewall as required by paragraph 4.1. of this Regulation as indicated on the sidewall."

"⁽²⁾ strike out what does not apply."

Annex 7

Paragraphs 1. to 1.2., delete.

Paragraph 1.3., renumber as paragraph 1. and amend to read:

"1. The traction test shall be performed according to ASTM standard:

- (a) F1805-06 in case SRTT14 is used as reference tyre or
- (b) F1805-20 in case SRTT16 is used as reference tyre."

Paragraph 1.4., delete.

Paragraph 2., amend to read:

"2. Spin traction method for classes C1 and C2 tyres (traction force test per paragraph 6.4. (b) of this Regulation)

The test procedure of ASTM standard F1805-06 or F1805-20, as applicable according to paragraph 1.3., shall be used to assess snow performance through the traction performance index (TPI) on medium pack snow (The snow compaction index measured with a CTI penetrometer¹ shall be between 70 and 80)."

"¹ See appendix of ASTM standard F1805-06 for details. "

Paragraph 3., amend to read:

"3. Braking on snow method for classes C1 and C2 tyres"

Paragraph 3.1.1., amend to read:

"3.1.1. Test course

The braking tests shall be done on a flat test surface of sufficient length and width, with a maximum 2 per cent gradient, covered with packed snow.

The snow surface shall be composed of a hard packed snow base at least 3 cm thick and a surface layer of medium packed and prepared snow about 2 cm thick.

The air temperature, measured about one metre above the ground, shall be between -15 °C and -2 °C; the snow temperature, measured at a depth of about one centimetre, shall be between -15 °C and -4 °C.

It is recommended to avoid direct sunlight, large variations of sunlight or humidity, as well as wind.

The snow compaction index measured with a CTI penetrometer shall be between 75 and 85."

Paragraph 3.1.4.1., amend to read:

"3.1.4.1. For class C1 tyres, the vehicle load shall be such that the resulting loads on the tyres are between 60 per cent and 90 per cent of the load corresponding to the tyre load index.

The cold inflation pressure shall be 240 kPa."

Paragraph 3.1.4.2., amend to read:

"3.1.4.2. For class C2 tyres, the vehicle load shall be such that the resulting loads on the tyres are between 60 per cent and 100 per cent of the load corresponding to the tyre load index. ..."

Paragraph 3.1.6., amend to read:

"3.1.6. In order to run this test, the Standard Reference Test Tyres (~~SRTT~~) as shown in the following table shall be used:

| Class C1 tyres | Class C2 tyres |
|------------------|----------------|
| SRTT14 or SRTT16 | SRTT16C |

"

Paragraph 3.4.2., amend to read:

"3.4.2. Statistical validations

The sets of repeats of measured or computed mffd for each tyre should be examined for normality, drift, eventual outliers.

The consistency of the arithmetic means \bar{a} and corrected sample standard deviations σ_a of successive braking tests of SRTT should be examined.

In addition and in order to take in account possible test evolution, the coefficient of validation $CVal_a(\text{SRTT})$ is calculated on the basis of the average values of any two consecutive groups of the minimum 6 runs of the Standard Reference Test Tyre according to

$$CVal_a(\text{SRTT}) = 100\% \times \left| \frac{\bar{a}_{R2} - \bar{a}_{R1}}{\bar{a}_{R1}} \right|$$

The coefficient of validation $CVal_a(\text{SRTT})$ shall not differ by more than 5 per cent.

The coefficient of variation CV_a , as defined in paragraph 3.4.1.1. of this Annex, of any braking test shall be less than 6 per cent.

If those conditions are not met, tests shall be performed again after re-grooming the test course."

Paragraph 4., amend to read:

"4. Acceleration method for class C3 tyres"

Paragraph 4.3.2., amend to read:

"4.3.2. The following tolerances shall be respected:

- (a) For speed measurements: ± 1 per cent or 0.5 km/h whichever is greater.
- (b) For distance measurements: $\pm 1 \times 10^{-1}$ m"

Paragraph 4.4.1.3., amend to read:

"4.4.1.3. The air temperature, measured about one metre above the ground, shall be between -15 °C and -2 °C; the snow temperature, measured at a depth of about one centimetre, shall be between -15 °C and -4 °C.

Air temperature shall not vary more than 10 °C during the test."

Paragraph 4.7., amend to read:

"4.7. Acceleration on snow test procedure for snow grip index of class C3"

Paragraph 4.7.2.1.1., amend to read:

"4.7.2.1.1. In the particular case where a standard commercial vehicle equipped with a traction control system is not available, a vehicle without Traction Control/ASR/TCS is permitted provided the vehicle is fitted with a system to

display the percentage slip as stated in paragraph 4.3.4. of this Annex and a mandatory differential lock on the driven axle used in accordance with operating procedure 4.7.5.2.1. below. If a differential lock is available it shall be used; if the differential lock, however, is not available, the average slip ratio should be measured on the left and right driven wheel."

Paragraph 4.7.5.2.1., amend to read:

"4.7.5.2.1. In the particular case of paragraph 4.7.2.1.1. of this Annex where a standard commercial vehicle equipped with a traction control system is not available, the driver shall manually maintain the average slip ratio between 10 and 40 per cent (controlled slip procedure in place of the full slip) within the prescribed range of speeds. If a differential lock is not available, the averaged slip ratio difference between the left and right driven wheel shall not be higher than 8 per cent for each run. All the tyres and runs in the test session are performed with controlled slip procedure."

Paragraph 4.7.5.5., amend to read:

"4.7.5.5. In case of traction control system equipped vehicle, the average slip ratio shall be in the range from 10 per cent to 40 per cent (calculated as per paragraph 4.3.4. of this Annex)."

Paragraph 4.8.5., amend to read:

"4.8.5. Calculation of the slip ratio

The slip ratio can be calculated as the average of slip ratio as mentioned in paragraph 4.3.4. of this Annex or by comparing the average distance referred to in paragraph 4.7.5.3. of this Annex of the minimum 6 runs to the distance of a run done without slip (very low acceleration)

$$\text{Slip Ratio \%} = \left[\frac{\text{Average distance} - \text{No slip distance}}{\text{No slip distance}} \right] \times 100$$

No slip distance means the wheel distance calculated on a run done with a constant speed or a continuous low acceleration."

Paragraph 4.9.2., amend to read:

"4.9.2. Principle of the approach

The principle lies upon the use of a control tyre and 2 different vehicles for the assessment of a candidate tyre in comparison with a reference tyre.

One vehicle can fit the reference tyre and the control tyre, the other the control tyre and the candidate tyre. All conditions are in conformity with paragraph 4.7. above.

The first assessment is a comparison between the control tyre and the reference tyre. The result (snow grip index SG1) is the relative efficiency of the control tyre compared to the reference tyre.

The second assessment is a comparison between the candidate tyre and the control tyre. The result (snow grip index SG2) is the relative efficiency of the candidate tyre compared to the control tyre.

The second assessment is done on the same track as the first one. The air temperature must be in the range of ± 5 °C of the temperature of the first assessment. The control tyre set is the same set as the set used for the first assessment.

The snow grip index SG of the candidate tyre compared to the reference tyre is deduced by multiplying the relative efficiencies calculated above:

$$\text{SG} = \text{SG1} \cdot \text{SG2}"$$

Annex 7 – Appendix 2,

Title, amend to read:

"Test reports and test data for classes C1 and C2 tyres"

Part 2., item 2.1., amend to read:

"2.1. Test track characteristics:

| | <i>At start of tests</i> | <i>At end of tests</i> | <i>Specification</i> |
|---------------------|--------------------------|------------------------|----------------------|
| Weather | | | |
| Ambient temperature | | | -15 °C to -2 °C |
| Snow temperature | | | -15 °C to -4 °C |
| CTI index | | | 75 to 85 |
| Other | | | |

"

Part 2., item 5, amend to read:

"5. Test results: mean fully developed decelerations ($m \cdot s^{-2}$) / traction coefficient⁽³⁾

| <i>Run number</i> | <i>Specification</i> | <i>SRTT (1st test)</i> | <i>Candidate 1</i> | <i>Candidate 2</i> | <i>SRTT (2nd test)</i> |
|---------------------------|--------------------------|------------------------|--------------------|--------------------|------------------------|
| 1 | | | | | |
| 2 | | | | | |
| 3 | | | | | |
| 4 | | | | | |
| 5 | | | | | |
| 6 | | | | | |
| | | | | | |
| | | | | | |
| | | | | | |
| Mean | | | | | |
| Standard deviation | | | | | |
| Coefficient of variation | $CV_a \leq 6 \%$ | | | | |
| Coefficient of Validation | $CVal_a(SRTT) \leq 5 \%$ | | | | |
| SRTT weighted average | | | | | |
| Factor <i>f</i> | | | | | |
| Snow grip index | | 1.00 | | | |

⁽¹⁾ for class C2 tyres, corresponding to the indication of the inflation pressure marked on the sidewall as required by paragraph 4.1. of this Regulation

⁽²⁾ for class C2 tyres, refer to single load

⁽³⁾ Strike out what does not apply."

Annex 7 – Appendix 3,

Title, amend to read:

"Test reports and test data for class C3 tyres"

Part 2., item 2.1., amend to read:

"2.1. Test track characteristics:

| | <i>At start of tests</i> | <i>At end of tests</i> | <i>Specification</i> |
|---------------------|--------------------------|------------------------|----------------------|
| Weather | | | |
| Ambient temperature | | | –15 °C to –2 °C |
| Snow temperature | | | –15 °C to –4 °C |
| CTI index | | | 80 to 90 |
| Other | | | |

"

Insert a new Annex 8, to read:

"Annex 8

Procedures for ice performance testing relative to ice grip tyre of class C1

1. Specific definitions for ice performance test when different from existing ones
 - 1.1. "Non-consecutive braking test cycles" means test cycles of braking tests performed at least after minimum refreshing (or new preparation) of the ice surface, or on a different test lane, or in a different day.
 - 1.2. "Reference load" (Q_{ref}) means the theoretical load capacity of a tyre at the test inflation pressure. It is expressed in kilograms. It may exceed the maximum load-carrying capacity of the test tyre as indicated by its load index.
 - 1.3. "Load-on-tyre rate" (R_{LOT}) means the actual static tyre load on the test vehicle divided by the reference load.
 - 1.4. "Set of tyres" means a set of four tyres.
2. Braking on ice method for class C1 tyres

The ice performance is determined by a testing method in which the mean fully developed deceleration of a candidate tyre in an ABS braking test on a flat surface made of ice is compared with that of a reference tyre.

For determination of the ice performance, braking tests of a candidate tyre shall be performed in three (3) non-consecutive braking test cycles.

The relative performance shall be indicated by an ice grip index (G_i).

 - 2.1. General conditions
 - 2.1.1. Test course
 - 2.1.1.1. The braking tests shall be done on a flat test surface of sufficient length and width covered with smooth ice with a maximum of 2 per cent gradient.
 - 2.1.1.2. The test course surface shall be flat, smooth, polished ice and watered around at least one hour before testing. The water used to make the ice shall be clean

and free of any solid inclusions. Before starting the test, the braking line should be conditioned by conducting braking runs with a set of tyres not involved in the test program until the friction level stabilizes. The exact same test line shall be used for all braking test repetitions.

- 2.1.1.3. The surface grip level shall be controlled by measurements with the reference tyre. The average mean fully developed deceleration of the reference tyre shall be not less than 0.9 m/s² and not greater than 1.6 m/s² in each braking test.
- 2.1.1.4. The air temperature, measured about one meter above the ground, shall be between -15 °C and +4 °C; the ice temperature, measured on the surface of the conditioned line, shall be between -15 °C and -5 °C. Both air and ice temperatures shall be reported for each tested tyre.
- 2.1.1.5. Test cannot be conducted during snow fall or rain fall or any atmospheric precipitation. It is recommended to avoid direct sunlight, large variations of sunlight or humidity, as well as wind.
- 2.1.1.6. Indoor as well as outdoor facilities for ice tracks are accepted as far as the above requirements are met.
- 2.1.2. Vehicle
 - 2.1.2.1. The test shall be conducted with a commercialized-model passenger car equipped with an ABS system in mechanical condition according to car manufacturer recommendations. Permitted modifications are as follows: those allowing the number of tyres sizes that can be mounted on the vehicle to be increased, those permitting automatic activation of the braking device to be installed. Any other modification of the braking system is prohibited. Increasing load on tyre by adding weight into the vehicle is permitted. Rim adapters or "spacers" for mounting wheels on the vehicle shall not exceed 60 mm.
- 2.1.3. Tyres
 - 2.1.3.1. Standard Reference Test Tyre

For the evaluation of the ice performance of class C1 tyres, the Standard Reference Test Tyre SRTT16 shall be used. The reference tyre shall not be older than 30 months starting from the production week and shall be stored in accordance with ASTM F2493 – 20. "
 - 2.1.3.2. Tyres preparation
 - 2.1.3.2.1. Fit each test tyres on an approved rim pursuant to ISO 4000-1 using conventional mounting methods. Subject to the foregoing, the rim width code shall not differ more than 0.5 from the measuring rim. If a commercialized rim is not available for the test vehicle, it will be acceptable to use a rim whose rim width code differs by 1.0 from the measuring rim width code. Ensure proper bead seating by the use of a suitable lubricant. Excessive use of lubricant should be avoided to prevent slipping of the tyre on the wheel rim.
 - 2.1.3.2.2. The tyres should be "broken-in" prior to testing (at least 100 km on dry roads or with an equivalent method) to ensure stable performance and to remove spew, compound nodules or flash resulting from the moulding process. The tyre designed tread depth and designed tread block or rib integrity shall not change significantly with break-in, which means the pace and "severity" of the break-in run needs to be carefully controlled to avoid such changes.
 - 2.1.3.2.3. It is acceptable to recondition a test tyre before the braking test to reach a stabilized performance level. ¹
 - 2.1.3.2.4. The tyre surface in contact with ice shall be cleaned before performing the test, removing snow and dirt.

⁽¹⁾ It can be done, for example, by driving 5 km to 10 km on rough road surfaces or equivalent.

- 2.1.3.2.5. Tyre and wheel assemblies shall be conditioned at the ambient temperature (outdoor or indoor depending on the test facility) at least two hours before they are fitted on the vehicle for tests. Tyre pressures shall then be adjusted to the values specified for the test.
- 2.1.3.2.6. In case a vehicle cannot accommodate both the reference and candidate tyres, a third tyre ("control" tyre) may be used as an intermediate. First, test the control tyre versus the reference on a suitable vehicle, then test the candidate tyre versus the control tyre on the selected vehicle.
- 2.1.4. Tyre load and inflation pressure
- 2.1.4.1. Tyre load and inflation pressure shall be adjusted according to Table 1 (depending on a direct comparison of candidate and reference tyre on the same vehicle, or an indirect comparison by using a control tyre and another vehicle).

Table 1
Tyre load and inflation pressure

| | Reference tyre | Control tyre | Candidate tyre |
|---|--|--|--|
| Direct comparison | <u>Inflation pressure:</u> $230 \text{ kPa} \leq p_{\text{test}} \leq 260 \text{ kPa}$ <u>Load-on-tyre rate:</u> $65 \% \leq R_{\text{LoT}}(\text{R}) \leq 75 \%$ | X | <u>Inflation pressure:</u> $190 \text{ kPa} \leq p_{\text{test}} \leq 270 \text{ kPa}$ <u>Load-on-tyre rate:</u> $R_{\text{LoT}}(\text{R}) - 15\% \leq R_{\text{LoT}}(\text{T}) \leq R_{\text{LoT}}(\text{R}) + 15\%$ |
| Indirect comparison | Vehicle 1: <u>Inflation pressure:</u> $230 \text{ kPa} \leq p_{\text{test}} \leq 260 \text{ kPa}$ <u>Load-on-tyre rate:</u> $65 \% \leq R_{\text{LoT},1}(\text{R}) \leq 75 \%$ | Vehicle 1: <u>Inflation pressure:</u> $190 \text{ kPa} \leq p_{\text{test}} \leq 270 \text{ kPa}$ <u>Load-on-tyre rate:</u> $R_{\text{LoT},1}(\text{R}) - 15\% \leq R_{\text{LoT},1}(\text{C}) \leq R_{\text{LoT},1}(\text{R}) + 15\%$ | X |
| | X | Vehicle 2: <u>Inflation pressure:</u> $190 \text{ kPa} \leq p_{\text{test}} \leq 270 \text{ kPa}$ <u>Load-on-tyre rate:</u> $R_{\text{LoT},1}(\text{C}) - 15\% \leq R_{\text{LoT},2}(\text{C}) \leq R_{\text{LoT},1}(\text{C}) + 15\%$ | Vehicle 2: <u>Inflation pressure:</u> $190 \text{ kPa} \leq p_{\text{test}} \leq 270 \text{ kPa}$ <u>Load-on-tyre rate:</u> $60 \% \leq R_{\text{LoT},2}(\text{T}) \leq 90 \%$ |
| Load-on-tyre rate R_{LoT} is given by $R_{\text{LoT}} = 100\% \cdot \frac{Q_{\text{tyre}}}{Q_{\text{ref}}}$ where Q_{tyre} is the actual static tyre load on the test vehicle, and Q_{ref} is the reference load at the test inflation pressure as determined below. | | | |

- 2.1.4.2. The reference load Q_{ref} at the test inflation pressure p_{test} is determined according to

$$Q_{\text{ref}} = Q_{\text{LI}} \cdot \left(\frac{p_{\text{test}}}{p_{\text{ref}}} \right)^{0.8}$$

where

Q_{LI} is the maximum tyre load-carrying capacity according to its load index, and

p_{ref} is the reference inflation pressure as defined in Table 2.

Table 2
Reference inflation pressures

| <i>Tyre</i> | <i>p_{ref} (kPa)</i> |
|--|------------------------------|
| Reference tyre | 250 |
| Standard tyre | 250 |
| Reinforced tyre (or "extra load" tyre) | 290 |

2.1.5. Instrumentation

2.1.5.1. The vehicle shall be fitted with calibrated sensors suitable for measurements in cold and icy conditions. There shall be a data acquisition system to store measurements.

2.1.5.2. The accuracy of measurement sensors and systems shall be such that would allow a relative uncertainty⁽²⁾ of less than or equal to 1 per cent on the measured or computed mean fully developed deceleration.³

2.2. Testing order and braking test cycles

2.2.1. For each braking test of a test tyre, at least nine (9) valid test runs shall be performed.

2.2.2. Within one braking test cycle, up to two (2) candidate tyres may be tested. Several braking test cycles may be combined and the final braking test of the reference tyre of one braking test cycle may serve as the initial braking test of the subsequent braking test cycle.

⁽²⁾ Suitable methods for determining the relative measurement uncertainty can be found, for example, in ISO/IEC Guide 98-3, Uncertainty of measurement – Part 3: Guide to the expression of uncertainty in measurement (GUM:1995).

⁽³⁾ For example, in case the mean fully developed deceleration is computed according to paragraph 2.4.1.1. of this Annex, the accuracy of the measurements sensors or systems for the measurements of the distance (s) and of the speeds (v_i and v_f) should be such that the composition of their relative uncertainties, based on 2.4.1.1. of this Annex would allow to determine the mean fully developed deceleration with a relative uncertainty of less than or equal to 1 per cent.

EXAMPLE 1

For a braking test cycle with two candidate tyres, the order of testing is

$$R_i - T_1 - T_2 - R_f$$

where

R_i/R_f is the initial/final braking test of the reference tyre and

T_1, T_2 are the braking tests of the two candidate tyres to be evaluated.

EXAMPLE 2

The run order for a series of braking test cycles with a total of four (4) candidate tyre sets (T_1 to T_4) would be the following:

$$R_i - T_1 - T_2 - R_f/R_i - T_3 - T_4 - R_f,$$

where the final braking test of the reference tyre set (R_f) of the first braking test cycle serves as initial braking test (R_i) of the second braking test cycle.

For any candidate tyre at least three (3) non-consecutive braking test cycles shall be performed.

2.3. Test procedure

2.3.1. The vehicle shall be fitted on all four positions with the same tyres.

2.3.2. Drive the vehicle in a straight line at a speed about 5 km/h higher than the upper speed of the evaluation interval.

2.3.3. When the measuring zone has been reached, set the vehicle gear into neutral, press the brake pedal sharply down with a force sufficient to cause operation of the ABS on all wheels of the vehicle and to result in a stable deceleration of the vehicle and hold it down until the speed is 0 km/h.

2.3.4. The mean fully developed deceleration d_m shall be determined either between 15 km/h and 5 km/h or between 20 km/h and 5 km/h. It shall be computed from measurements of either time (expressed in s), distance (expressed in m), or deceleration (expressed in $m \cdot s^{-2}$). For each test run in the braking tests (3 or 4) of a braking test cycle and for all test tyres, the same evaluation speed interval shall be used.

2.4. Data evaluation and presentation of results

2.4.1. Data evaluation

2.4.1.1. For a distance measurement, the mean fully developed deceleration d_m in a test run is computed as:

$$d_m = \frac{v_i^2 - v_f^2}{2s}$$

where

v_i is the initial speed expressed in $m \cdot s^{-1}$

v_f is the final speed expressed in $m \cdot s^{-1}$, and

s is the distance, expressed in metres, covered between the initial speed and the final speed.

2.4.1.2. The highest and the lowest values (in total two (2) runs) of the at least nine valid test runs shall be disregarded in the evaluation of each braking test.

2.4.1.3. For each braking test in a braking test cycle, the arithmetic mean $d_{m,ave}$ and the standard deviation σ_d of the mean fully developed deceleration and the coefficient of variation CV_d shall be computed and reported:

$$\sigma_d = \sqrt{\frac{1}{N-1} \cdot \sum_{j=1}^N (d_{m,j} - d_{m,ave})^2}$$

and

$$CV_d = 100\% \cdot \frac{\sigma_d}{d_{m,ave}}$$

2.4.2. Calculation of the braking test ice grip index

2.4.2.1. For the calculation of the ice grip index $G_{I,k}(T_n)$ for an individual braking test, the mean fully developed deceleration of the reference tyre is adjusted according to the positioning of each candidate tyre (T_n) within a braking test cycle.

2.4.2.2. This adjusted mean fully developed deceleration $d_{m,adj}(R)$ of the reference tyre is calculated in accordance with Table 3, where $d_{m,ave}(R_i)$ and $d_{m,ave}(R_f)$ are the arithmetic means of the mean fully developed decelerations in the initial and in the final braking test of the reference tyre within a braking test cycle.

Table 3
Calculation of the adjusted mean fully developed deceleration $d_{m,adj}(R)$ of the reference tyre

| <i>If the number and the sequence of candidate tyres within one braking test cycle is</i> | <i>and the candidate tyre to be qualified is</i> | <i>the corresponding adjusted mean fully developed deceleration $d_{m,adj}(R)$ of the reference tyre is calculated as follows</i> |
|---|--|--|
| 1 R1 – T1 – R2 | T1 | $d_{m,adj}(R) = 1/2 \cdot [d_{m,ave}(R_i) + d_{m,ave}(R_f)]$ |
| 2 R1 –T1 – T2 – R2 | T1 | $d_{m,adj}(R) = 2/3 \cdot d_{m,ave}(R_i) + 1/3 \cdot d_{m,ave}(R_f)$ |
| | T2 | $d_{m,adj}(R) = 1/3 \cdot d_{m,ave}(R_i) + 2/3 \cdot d_{m,ave}(R_f)$ |

2.4.2.2. For an individual braking test, the ice grip index $G_{I,k}(T_n)$ of the candidate tyre T_n ($n = 1, 2$) relative to the reference tyre is calculated as:

$$G_{I,k}(T_n) = \frac{d_{m,ave}(T_n)}{d_{m,adj}(R)}$$

2.4.3. Ice grip index

The ice grip index $G_I(T_n)$ of a candidate tyre shall be computed as the arithmetic mean of the ice grip indices $G_{I,k}(T_n)$ for the individual braking tests in the three non-consecutive braking test cycles as :

$$G_I(T_n) = \frac{1}{3} \cdot [G_{I,1}(T_n) + G_{I,2}(T_n) + G_{I,3}(T_n)]$$

An example of a full test report is given in appendix 2.

2.4.4. Statistical validation

2.4.4.1. The sets of mean fully developed decelerations d_m within each braking test shall be examined for normality, drift, eventual outliers.

2.4.4.2. If the coefficient of variation CV_d of a braking test of a candidate tyre exceeds 6 per cent, this braking test shall be discarded.

2.4.4.3. In the case that

- the coefficient of variation CV_d of the initial or the final braking test of a reference tyre within a braking test cycle exceeds 6 per cent, or
- the arithmetic means of the mean fully developed decelerations of the initial and the final braking test of the reference tyre within a braking test cycle exceeds 5 per cent of the average of the two values:

$$CV_{val}(d_m) = 2 \cdot \left| \frac{d_{m,ave}(R_i) - d_{m,ave}(R_f)}{d_{m,ave}(R_i) + d_{m,ave}(R_f)} \right| \cdot 100\% \leq 5\%, \text{ or}$$

- the mean fully developed deceleration of the reference tyre is less than $0.9 \text{ m} \cdot \text{s}^{-2}$ or greater than $1.6 \text{ m} \cdot \text{s}^{-2}$ in the initial or the final braking test within a braking test cycle

the complete braking test cycle shall be discarded.

2.4.4.4. For each candidate tyre T_n , the coefficient of variation CV_G of the ice grip indices $G_{I,k}(T_n)$ for the individual braking tests in the three (3) non-consecutive braking test cycles shall be calculated as:

$$CV_G = 100\% \cdot \frac{\sigma_G}{G_I(T_n)}$$

where

$$\sigma_G = \sqrt{\frac{1}{2} \cdot \sum_{k=1}^3 [G_{I,k}(T_n) - G_I(T_n)]^2}$$

and

$G_I(T_n)$ is the ice grip index of candidate tyre T_n .

- 2.4.4.4. If the coefficient of variation CV_G exceeds 6%, for this candidate tyre T_n additional braking tests shall be performed in non-consecutive braking cycles, until the coefficient of variation CV_G calculated from any three braking tests of this candidate tyre meets the requirement.
- 2.4.4.5. The SRTT shall be discarded if it exhibits irregular wear or damage or when the performance appears to have been deteriorated.
- 2.4.5. Ice performance comparison between a candidate tyre and a reference tyre using a control tyre
- 2.4.5.1. General
- 2.4.5.1.1. In case the candidate tyre cannot be fitted on the same vehicle as the reference tyre, for example, due to tyre size, inability to achieve required load-on-tyre rate and required test inflation pressure, comparison shall be made using intermediate tyres, herein referred to as "control tyres", and two different vehicles.
- 2.4.5.1.2. The control tyre shall pass the ice grip index threshold defined in paragraph 6.4.2. of this Regulation.
- 2.4.5.1.3. One vehicle shall be capable of being fitted with the reference tyre and the control tyre, and the other vehicle shall be capable of being fitted with the control tyre and the candidate tyre.
- 2.4.5.2. Ice grip index calculation in case of a control tyre
- 2.4.5.2.1. In a first series of three non-consecutive braking test cycles, using the procedure described in paragraph 2.1.3.2. to 2.4.4.5. of this Annex in which the control tyre shall be treated as a candidate tyre, the ice grip index $G_{I,1}(C)$ of the control tyre relative to the reference tyre shall be established. In a second series of three non-consecutive braking test cycles, in which the control tyre serves as reference tyre, the ice grip index $G_{I,2}(T)$ of the candidate tyre relative to the control tyre shall be established.
- 2.4.5.2.2. The ice grip index $G_I(T)$ of the candidate tyre relative to the reference tyre shall be calculated as the product of the two ice grip indices:
- $$G_I(T) = G_{I,1}(C) \cdot G_{I,2}(T)$$
- 2.4.5.3. Boundary conditions
- 2.4.5.3.1. The same set of control tyres shall be used for comparison with the SRTT and with the candidate tyre and shall be fitted in the same wheel positions.
- 2.4.5.3.2. Control tyres that have been used for testing shall subsequently be stored under the same conditions as required for the SRTT.
- 2.4.5.3.3. The SRTT and control tyres shall be discarded if there is irregular wear or damage or when the performance appears to have been deteriorated.

Annex 8 - Appendix 1

Pictogram definition of "Ice Grip Symbol"

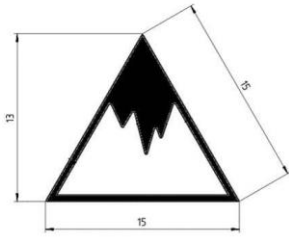

Minimum 15 mm base and 13 mm height.

Above drawing not to scale.

Annex 8 - Appendix 2

Test reports and test data for C1 tyres

Part 1 - Report

1. Type Approval Authority or Technical Service:
2. Name and address of manufacturer:
3. Test report No.:
4. Brand name and trade description:
5. Tyre class:
6. Category of use:
7. Ice grip index relative to SRTT
- 7.1. Test procedure and SRTT used
8. Comments (if any):
9. Date:
10. Signature:

Part 2 - Test data: 1st braking test cycle

1. Date of test:
2. Location of test track:
- 2.1. Test track characteristics:

| | <i>At start of test</i> | <i>At end of test</i> | <i>Specification</i> |
|---------------------|-------------------------|-----------------------|----------------------|
| Weather | | | |
| Ambient temperature | | | -15 °C to +4 °C |
| Ice temperature | | | -15 °C to -5 °C |
| Other | | | |

3. Test vehicle (make, model and type, year):
4. Test tyre details and data

| | <i>SRTT (Initial braking test)</i> | <i>Candidate 1</i> | <i>Candidate 2</i> | <i>SRTT (final braking test)</i> |
|--|------------------------------------|--------------------|--------------------|----------------------------------|
| Brand name | | | | |
| Trade description/ commercial name | | | | |
| Tyre size designation | | | | |
| Service description | | | | |
| Test rim width code | | | | |
| Tyre load FL/FR/RL/RR (kg) | | | | |
| Load-on-tyre rate (FL/FR/RL/RR) (%) | | | | |
| Tyre pressure (kPa) | | | | |

5. Test results: mean fully developed decelerations ($m \cdot s^{-2}$)

| <i>Run number</i> | <i>SRTT (Initial braking test)</i> | <i>Candidate 1</i> | <i>Candidate 2</i> | <i>SRTT (final braking test)</i> |
|-------------------------|------------------------------------|--------------------|--------------------|----------------------------------|
| 1 | | | | |
| 2 | | | | |
| 3 | | | | |
| 4 | | | | |
| 5 | | | | |
| 6 | | | | |
| 7 | | | | |
| 8 | | | | |
| 9 | | | | |
| | | | | |
| $d_{m,ave}$ | | | | |
| σ_d | | | | |
| $CV_d (\leq 6 \%)$ | | | | |
| $CV_d(d_m) (\leq 5 \%)$ | | | | |
| $d_{m,adj}(R)$ | | | | |
| Ice grip index | 1.00 | | | |

Part 2 - Test data: 2nd braking test cycle

1. Date of test:
2. Location of test track:
- 2.1. Test track characteristics:

| | <i>At start of test</i> | <i>At end of test</i> | <i>Specification</i> |
|---------------------|-------------------------|-----------------------|----------------------|
| Weather | | | |
| Ambient temperature | | | -15 °C to +4 °C |
| Ice temperature | | | -15 °C to -5 °C |

| | <i>At start of test</i> | <i>At end of test</i> | <i>Specification</i> |
|-------|-------------------------|-----------------------|----------------------|
| Other | | | |

3. Test vehicle (make, model and type, year):

4. Test tyre details and data

| | <i>SRTT (Initial braking test)</i> | <i>Candidate 1</i> | <i>Candidate 2</i> | <i>SRTT (final braking test)</i> |
|--|------------------------------------|--------------------|--------------------|----------------------------------|
| Brand name | | | | |
| Trade description/ commercial name | | | | |
| Tyre size designation | | | | |
| Service description | | | | |
| Test rim width code | | | | |
| Tyre load FL/FR/RL/RR (kg) | | | | |
| Load-on-tyre rate (FL/FR/RL/RR) (%) | | | | |
| Tyre pressure (kPa) | | | | |

5. Test results: mean fully developed decelerations ($m \cdot s^{-2}$)

| <i>Run number</i> | <i>SRTT (Initial braking test)</i> | <i>Candidate 1</i> | <i>Candidate 2</i> | <i>SRTT (final braking test)</i> |
|------------------------|------------------------------------|--------------------|--------------------|----------------------------------|
| 1 | | | | |
| 2 | | | | |
| 3 | | | | |
| 4 | | | | |
| 5 | | | | |
| 6 | | | | |
| 7 | | | | |
| 8 | | | | |
| 9 | | | | |
| | | | | |
| $d_{m,ave}$ | | | | |
| σ_d | | | | |
| $CV_d (\leq 6 \%)$ | | | | |
| $CVal(d_m) (\leq 5\%)$ | | | | |
| $d_{m,adj}(R)$ | | | | |
| Ice grip index | 1.00 | | | |

Part 2 - Test data: 3rd braking test cycle

1. Date of test:

2. Location of test track:

2.1. Test track characteristics:

| | <i>At start of test</i> | <i>At end of test</i> | <i>Specification</i> |
|---------------------|-------------------------|-----------------------|----------------------|
| Weather | | | |
| Ambient temperature | | | -15 °C to +4 °C |
| Ice temperature | | | -15 °C to -5 °C |
| Other | | | |

3. Test vehicle (make, model and type, year):

4. Test tyre details and data

| | <i>SRTT (Initial braking test)</i> | <i>Candidate 1</i> | <i>Candidate 2</i> | <i>SRTT (final braking test)</i> |
|--|------------------------------------|--------------------|--------------------|----------------------------------|
| Brand name | | | | |
| Trade description/ commercial name | | | | |
| Tyre size designation | | | | |
| Service description | | | | |
| Test rim width code | | | | |
| Tyre load FL/FR/RL/RR (kg) | | | | |
| Load-on-tyre rate (FL/FR/RL/RR) (%) | | | | |
| Tyre pressure (kPa) | | | | |

5. Test results: mean fully developed decelerations ($m \cdot s^{-2}$)

| <i>Run number</i> | <i>SRTT (Initial braking test)</i> | <i>Candidate 1</i> | <i>Candidate 2</i> | <i>SRTT (final braking test)</i> |
|-------------------------|------------------------------------|--------------------|--------------------|----------------------------------|
| 1 | | | | |
| 2 | | | | |
| 3 | | | | |
| 4 | | | | |
| 5 | | | | |
| 6 | | | | |
| 7 | | | | |
| 8 | | | | |
| 9 | | | | |
| | | | | |
| | | | | |
| $d_{m,ave}$ | | | | |
| σ_d | | | | |
| $CV_d (\leq 6 \%)$ | | | | |
| $CV_d(d_m) (\leq 5 \%)$ | | | | |
| $d_{m,adj}(R)$ | | | | |
| Ice grip index | 1.00 | | | |

"

20 February 2023

Agreement

Concerning the Adoption of Harmonized Technical United Nations Regulations for Wheeled Vehicles, Equipment and Parts which can be Fitted and/or be Used on Wheeled Vehicles and the Conditions for Reciprocal Recognition of Approvals Granted on the Basis of these United Nations Regulations*

(Revision 3, including the amendments which entered into force on 14 September 2017)

Addendum 116 – UN Regulation No. 117

Revision 4 - Amendment 7

03 series of amendments – Date of entry into force: 4 January 2023.

Uniform provisions concerning the approval of tyres with regard to rolling sound emissions and/or to adhesion on wet surfaces and/or to rolling resistance

This document is meant purely as documentation tool. The authentic and legal binding text is: ECE/TRANS/WP.29/2022/83.



UNITED NATIONS

* Former titles of the Agreement:

Agreement concerning the Adoption of Uniform Conditions of Approval and Reciprocal Recognition of Approval for Motor Vehicle Equipment and Parts, done at Geneva on 20 March 1958 (original version); Agreement concerning the Adoption of Uniform Technical Prescriptions for Wheeled Vehicles, Equipment and Parts which can be Fitted and/or be Used on Wheeled Vehicles and the Conditions for Reciprocal Recognition of Approvals Granted on the Basis of these Prescriptions, done at Geneva on 5 October 1995 (Revision 2).

Table of contents, Annexes, at the end add a reference to a new Annex 9 to read:

"9 Test procedure for measuring the adhesion on wet surfaces of tyres in worn state
Appendix 1 Worn tyre preparation report example
Appendix 2 Test reports examples of wet grip index for tyres in worn state "

Paragraph 1.1., amend to read:

"1.1. This Regulation applies to new pneumatic tyres* of classes C1, C2 and C3 in new state with regard to their sound emissions, rolling resistance and to adhesion performance on wet surfaces (wet adhesion) and for class C1 tyres in worn state with regard to adhesion performance on wet surfaces (wet adhesion). It does not, however, apply to:

* For the purpose of this Regulation "tyres" means "pneumatic tyres"

Paragraph 1.2., amend to read:

"1.2. Contracting Parties shall issue or accept approvals to rolling sound and/or adhesion of tyres in new state on wet surfaces and/or adhesion of tyres in worn state on wet surfaces and/or rolling resistance."

Paragraph 2.7., amend to read:

"2.7. *"Representative tyre size"* means the tyre size which is submitted to the test described in Annex 3 to this Regulation with regard to rolling sound emissions, or Annex 5 for adhesion on wet surfaces or Annex 6 for rolling resistance to assess the conformity for the type approval of the type of tyre, or Annex 7 for measuring snow performance, or Annex 8 for measuring ice performance, or Annex 9 for adhesion on wet surfaces of class C1 tyres in worn state."

Paragraph 2.13.1., amend to read:

"2.13.1. *"Snow tyre for use in severe snow conditions"* means a snow tyre whose tread pattern, tread compound or structure is specifically designed to be used in severe snow conditions and that fulfils the requirements of paragraphs 6.5. and 6.5.1. of this Regulation."

Insert new paragraphs 2.19.17. and 2.19.18., to read:

"2.19.17. *"Tyre in worn state"* or *"worn tyre"* means the tyre in a state as defined in Annex 9 to this Regulation.

2.19.18. *"Tyre in new state"* means the tyre in a state as defined in Annex 9 to this Regulation."

Paragraph 3.1.1., amend to read:

"3.1.1. The performance characteristics to be assessed for the type of tyre; "rolling sound emissions level" and/or "adhesion performance level on wet surfaces of a tyre in new state" and/or "adhesion performance level on wet surfaces of a tyre in worn state" and/or "rolling resistance level"; "snow performance level" in case of "snow tyre for use in severe snow conditions" and additionally "ice performance level" in case of ice grip tyre;"

Paragraph 4.3.1., amend to read:

"4.3.1. In case the approval of a tyre pursuant to this Regulation has been granted by the same Type Approval Authority than that granting the approval pursuant to UN Regulations Nos. 30 or 54, the approval mark pursuant to UN Regulations Nos. 30 or 54 can be combined with an indication of the applicable series of amendments to which the tyre was approved pursuant to UN Regulation No. 117 on the form of 2 digits (example "03" indicating that the UN Regulation No. 117 approval was granted following the 03 series of

amendments) and the suffixes according to paragraph 5.2.2. using the addition sign "+", as described in Annex 2, Appendix 3 of this Regulation, for example "0236378 + 03S2WR2B".

Paragraph 5.2.2., amend to read:

"5.2.2. The communication form mentioned in paragraph 5.3. below shall identify specific performance parameters of UN Regulation No. 117 by the following suffixes:

- S To identify additional conformity to the requirements on tyre rolling sound emissions;
- W To identify additional conformity to the requirements on adhesion on wet surfaces of tyres in new state;
- R To identify additional conformity to the requirements on tyre rolling resistance;
- B To identify additional conformity to the requirements on adhesion on wet surfaces of tyres in worn state.

S and R will be followed by the suffix "2" for compliance to stage 2."

Paragraph 5.3.1.2., amend to read:

"5.3.1.2. The suffix(es) mentioned in paragraph 5.2.2. above shall be preceded by the two digits identifying the series of amendments of the prescription on tyre performances for UN Regulation No. 117, e.g. 03S2 to identify the third series of amendments on tyre road rolling sound emissions at stage 2 or 03S2WR2 to identify the third series of amendments on tyre road rolling sound emissions at stage 2, adhesion on wet surfaces of a tyre in new state and rolling resistance at stage 2."

Paragraph 5.4.3., amend to read:

"5.4.3. The suffix(es), and the identification to the relevant series of amendments, if any, as specified in the communication form.

One of the suffixes listed below or any combination of them can be used.

| | |
|----|---|
| S2 | Rolling sound emission level at stage 2 |
| W | Wet adhesion level of tyres in new state |
| R2 | Rolling resistance level at stage 2 |
| B | Wet adhesion level of tyres in worn state |

These suffixes shall be placed to the right or below the approval number, if part of the original approval.

If the approval is extended subsequent to UN Regulations Nos. 30 or 54 approvals, the addition sign "+" and the series of amendment to UN Regulation No. 117 shall be placed in front of the suffix or any combination of suffixes to denote an extension to the approval.

If the approval is extended subsequent to the original approval under UN Regulation No. 117, the addition sign "+" shall be placed between the suffix or any combination of suffixes of the original approval and the suffix or any combination of suffixes added to denote an extension to the approval."

Paragraph 6.1.1., amend to read:

"6.1.1. For class C1 tyres, the rolling sound emission value shall not exceed the values given below. These values refer to the nominal section width as defined in UN Regulation No. 30:

| <i>Stage 2</i> | |
|------------------------------|--------------------|
| <i>Nominal section width</i> | <i>Limit dB(A)</i> |
| 185 and lower | 70 |
| Over 185 up to 245 | 71 |
| Over 245 up to 275 | 72 |
| Over 275 | 74 |

The above limits shall be increased by 1 dB(A) for "snow tyre for use in severe snow conditions", extra load tyres or reinforced tyres, or any combination of these classifications.

"

Paragraph 6.1.2., amend to read:

"6.1.2. For class C2 tyres, the rolling sound emission value with reference to its category of use (see paragraph 2.1., subparagraph (d) above) shall not exceed the values given below:

| <i>Stage 2</i> | | |
|------------------------|---|-----------------------|
| <i>Category of use</i> | <i>Limit dB(A)</i> | |
| | <i>Other</i> | <i>Traction tyres</i> |
| Normal tyre | 72 | 73 |
| Snow tyre | 72 | 73 |
| | Snow tyre for use in severe snow conditions | 75 |
| Special use tyre | 74 | 75 |

"

Paragraph 6.1.3., amend to read:

"6.1.3. For class C3 tyres, the rolling sound emission value with reference to its category of use (see paragraph 2.1., subparagraph (d) above) shall not exceed the values given below:

| <i>Stage 2</i> | | |
|------------------------|---|-----------------------|
| <i>Category of use</i> | <i>Limit dB(A)</i> | |
| | <i>Other</i> | <i>Traction tyres</i> |
| Normal tyre | 73 | 75 |
| Snow tyre | 73 | 75 |
| | Snow tyre for use in severe snow conditions | 76 |
| Special use tyre | 75 | 77 |

"

Paragraph 6.2., amend to read:

"6.2. The wet adhesion of tyres in new state will be based on a procedure that compares either peak brake force coefficient ("pbfc") or mean fully developed deceleration ("mfdd") against values achieved by a Standard Reference Test Tyre (SRTT). The relative performance shall be indicated by a wet grip index (G)."

Paragraph 6.3., amend to read:

"6.3. Rolling resistance coefficient limits, as measured by the method described in Annex 6 to this Regulation.

The maximum values for stage 2 for the rolling resistance coefficient shall not exceed the following (value in N/kN is equivalent to value in kg/tonne):

| Tyre class | Max value (N/kN) |
|------------|------------------|
| C1 | 10.5 |
| C2 | 9.0 |
| C3 | 6.5 |

For "snow tyre for use in severe snow conditions", the limits shall be increased by 1 N/kN.

"

Insert a new paragraph 6.4., to read:

"6.4. The wet adhesion of tyres in worn state shall be based on a procedure defined in Annex 9 to this Regulation.

6.4.1. For class C1 tyres, tested in accordance with either procedure given in Annex 9 to this Regulation, the tyre shall meet the following requirements:

| Category of use | Wet grip index (G_B) | |
|------------------|--|-------------|
| Normal tyre | ≥ 0.88 | |
| Snow tyre | ≥ 0.80 | |
| | "Snow tyre for use in severe snow conditions" and with a speed category symbol ("R" and above, including "H") indicating a maximum permissible speed greater than 160 km/h | ≥ 0.80 |
| | Ice grip tyre | ≥ 0.70 |
| | "Snow tyre for use in severe snow conditions" and with a speed category symbol ("Q" or below excluding "H") indicating a maximum permissible speed not greater than 160 km/h | ≥ 0.70 |
| Ice grip tyre | ≥ 0.70 | |
| Special use tyre | Not defined | |

For normal tyres with speed category symbol indicating a maximum permissible speed equal to or greater than 300 km/h and aspect ratio equal to or lower than 40, the limit shall be decreased by 0.08. "

Paragraph 6.4. (former) and its subparagraphs, renumber as 6.5. and its respective subparagraphs.

Paragraph 6.5., (former), renumber as 6.6. and amend to read:

"6.6. In order to be classified as a "traction tyre", a tyre is required to meet the conditions of paragraph 6.6.1. below."

Paragraphs 6.5.1. (former), 6.6. (former) and 6.7., renumber as 6.6.1., 6.7. and 6.8., respectively.

Insert a new paragraph 8.3.3., to read:

"8.3.3. In the case of verification tests with regard to approvals in accordance with paragraph 6.4. of this Regulation, these shall be carried out using the same testing method (see Annex 9 to this Regulation) as that adopted for the original approval."

Paragraph 12., amend to read:

"12. Transitional provisions

- 12.1. As from the official date of entry into force of the 03 series of amendments, no Contracting Party applying this Regulation shall refuse to grant or refuse to accept type approvals under this Regulation as amended by the 03 series of amendments.
- 12.2. Contracting Parties applying this Regulation shall continue to accept type approvals of and to grant extensions of approvals to, the classes C2 and C3 tyres, which are not affected by the changes of the technical requirements concerning the adhesion on wet surfaces of class C1 tyres in worn state introduced by the 03 series of amendments, to the 02 series of amendments to this Regulation.
- 12.3. As from 7 July 2024, Contracting Parties applying this Regulation shall not be obliged to accept type approvals of class C1 tyres to the 02 series of amendments, first issued after 7 July 2024.
- 12.4. Until 7 July 2026, Contracting Parties applying this Regulation shall accept type approvals of class C1 tyres to the 02 series of amendments, first issued before 7 July 2024.
- 12.5. As from 7 July 2026, Contracting Parties applying this Regulation shall not be obliged to accept type approvals of class C1 tyres issued to the 02 series of amendments to this Regulation.
- 12.6. Contracting Parties applying this Regulation may grant type approvals according to any preceding series of amendments to this Regulation.
- 12.6.1. Contracting Parties applying this Regulation shall continue to grant extensions of existing approvals to any preceding series of amendments to this Regulation.
- 12.7. Until 1 September 2024, Contracting Parties applying this Regulation may continue to grant type approvals according to the 0203 series of amendments to this Regulation, based on snow performance test described in Annex 7 to this Regulation using SRTT14 as reference tyre. ^(a)
- 12.8. Until 1 September 2024, Contracting Parties applying this Regulation may continue to grant type approvals according to the 03 series of amendments to this Regulation, based on the test procedures for measuring the wet adhesion of tyres in new state as described in Annex 5 of this Regulation, without taking into account the provisions introduced after Supplement 12 to the 02 series of amendments.

^(a) SRTT14 will be available from the supplier until end of October 2021."

Annex 1

Paragraph 8., amend to read:

- "8. Performance(s) approved: rolling sound emission level at stage 2, wet adhesion level of tyres in new state, rolling resistance level at stage 2, wet adhesion level of tyres in worn state"

Paragraph 8.2., amend to read:

- "8.2. Wet adhesion level of tyres in new state of representative size, see paragraph 2.7. of this Regulation, as per the test report examples shown in the appendix to Annex 5: (G) using the vehicle or trailer method²"

Insert a new paragraph 8.3., to read:

- "8.3. Wet adhesion level of tyres in worn state of representative size, see paragraph 2.7. of this Regulation, as per item Y. of the test report in the appendix to Annex 9: (G_B) using the vehicle or trailer method²"

Paragraphs 8.3. (former), 8.4. and 8.4.1., renumber as 8.4., 8.5. and 8.5.1., respectively.

Annex 2, Appendix 1, amend to read:

"Annex 2 - Appendix 1

Examples of separate UN Regulation No. 117 approval marks

Example 1

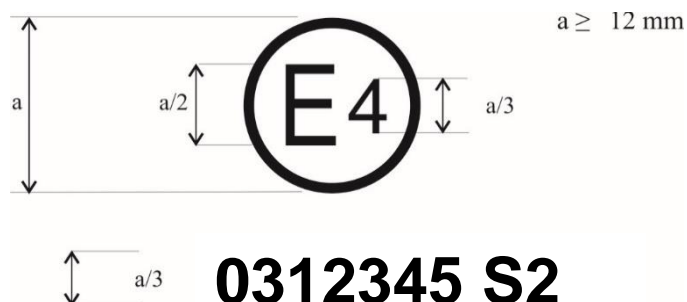

The above approval mark, affixed to a tyre shows that the tyre concerned has been approved in the Netherlands (E4) pursuant to UN Regulation No. 117 (marked by S2 (rolling sound emission at stage 2)), under approval number 0312345. The first two digits of the approval number (03) indicate that the approval was granted according to the requirements of the 03 series of amendments to this Regulation.

Example 2

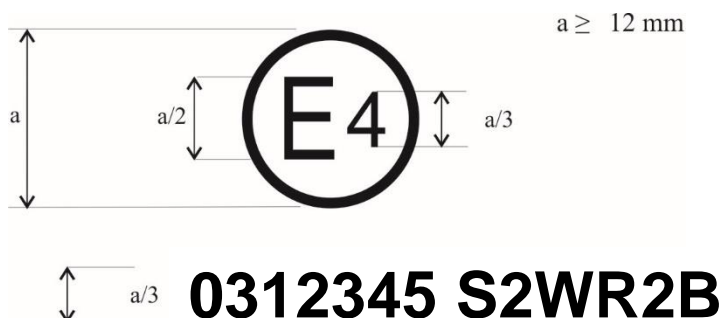

The above approval mark shows that the tyre concerned has been approved in the Netherlands (E4) pursuant to UN Regulation No. 117 (marked by S2 (rolling sound emission at stage 2), W (wet adhesion of tyres in new state), R2 (rolling resistance at stage 2) and B (wet adhesion of tyres in worn state)) under approval number 0312345. The first two digits of the approval number (03) indicate that the approval was granted according to the requirements of the 03 series of amendments to this Regulation."

Annex 2, Appendix 2, amend to read:

"Annex 2 - Appendix 2

Approval according to UN Regulation No. 117 coincident with approval of UN Regulations Nos. 30 or 54¹

¹ Approvals in accordance with UN Regulation No. 117 for tyres within the scope of UN Regulation No. 54 currently do not include the requirement on adhesion of tyres in worn state on wet surfaces.

Example 1

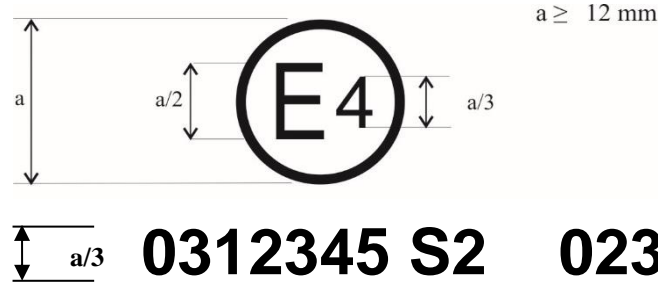

The above approval mark shows that the tyre concerned has been approved in the Netherlands (E4) pursuant to UN Regulation No. 117 (marked by "S2" (rolling sound emission at stage 2)), under approval number 0312345 and UN Regulation No. 30, under approval number 0236378. The first two digits of the approval numbers ("03" and "02") indicate that the approval pursuant to UN Regulation No. 117 was granted according to the 03 series of amendments and the approval pursuant to UN Regulation No. 30 according to the 02 series of amendments.

Example 2

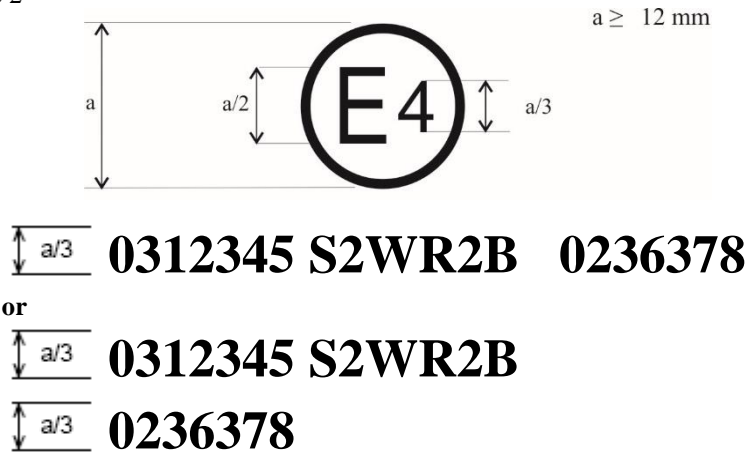

The above approval mark shows that the tyre concerned has been approved in the Netherlands (E4) pursuant to UN Regulation No. 117 (marked by "S2WR2B" (rolling sound emission at stage 2, wet adhesion of tyres in new state, rolling resistance at stage 2 and wet adhesion of tyres in worn state)), under approval number 0312345 and UN Regulation No. 30 under approval number 0236378. The first two digits of the approval numbers ("03" and "02") indicate that the approval pursuant to UN Regulation No. 117 was granted according to the 03 series of amendments and the approval pursuant to UN Regulation No. 30 according to the 02 series of amendments.

Example 3

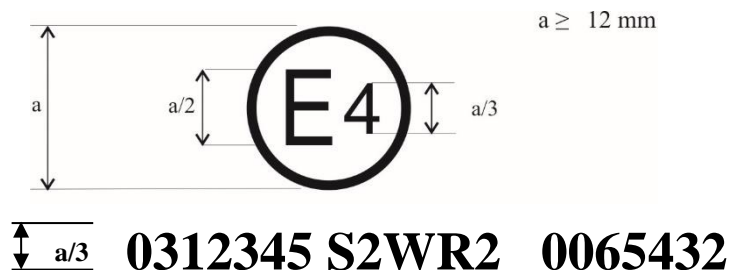

The above approval mark shows that the tyre concerned has been approved in the Netherlands (E4) pursuant to UN Regulation No. 117 (marked by "S2WR2" (rolling sound emission at stage 2, wet adhesion of tyres in new state and rolling resistance at stage 2)), under approval number 0312345 and UN Regulation No. 54 under approval number 0065432. The first two digits of the approval numbers ("03" and "00") indicate that

the approval pursuant to UN Regulation No. 117 was granted according to the 03 series of amendments and the approval pursuant to UN Regulation No. 54 according to its original form."

Annex 2, Appendix 3, amend to read:

"Annex 2 - Appendix 3

Combinations of markings of approvals issued in accordance with Regulations Nos. 117, 30 or 54 ²

Example 1

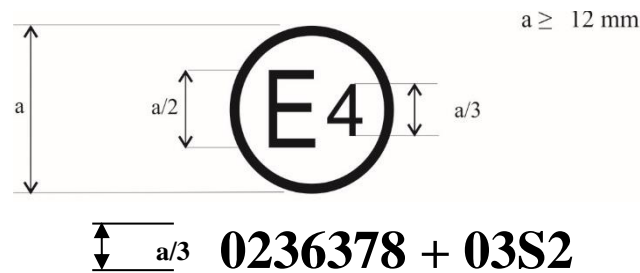

The above approval mark shows that the tyre concerned has been approved in the Netherlands (E4) pursuant to UN Regulation No. 30 according to its 02 series of amendments (indicated by the first two digits of the approval number, "02") under approval number 0236378. It is also marked by "+ 03S2" which indicates that the tyre was also approved pursuant to UN Regulation No. 117 (03 series of amendments) for S (rolling sound emission at stage 2).

Example 2

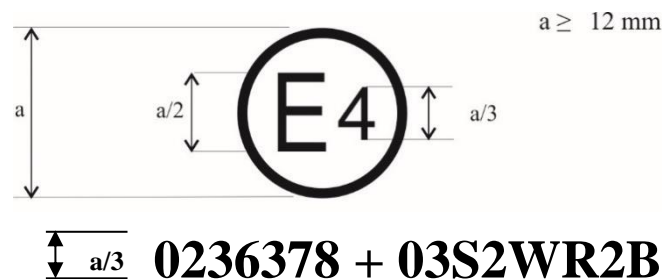

The above approval mark shows that the tyre concerned has been approved in the Netherlands (E4) pursuant to UN Regulation No. 30 according to its 02 series of amendments (indicated by the first two digits of the approval number, "02") under approval number 0236378. It is also marked by "+ 03S2WR2B" which indicates that the tyre was also approved pursuant to UN Regulation No. 117 (03 series of amendments) for S (rolling sound emission at stage 2) W (wet adhesion of tyres in new state), R (rolling resistance at stage 2) and B (wet adhesion of tyres in worn state)."

Annex 2, Appendix 4, amend to read:

"Annex 2 - Appendix 4

Extensions to combine approvals issued in accordance with Regulation No. 117

² Approvals in accordance with UN Regulation No. 117 for tyres within the scope of UN Regulation No. 54 currently do not include the requirement on adhesion of tyres in worn state on wet surfaces.

Example 1

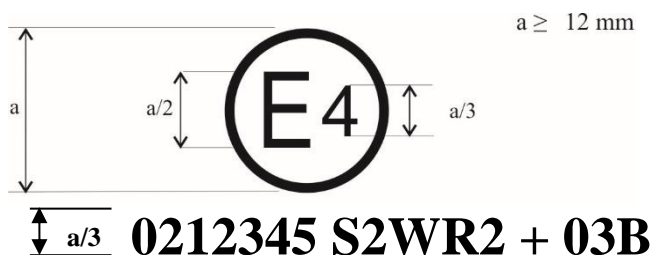

The above approval mark shows that the tyre concerned has been initially approved in the Netherlands (E4) pursuant to UN Regulation No. 117 and the 02 series of amendments under approval number 0212345. The marking is complemented by S2WR2 (rolling sound emission at stage 2) W (wet adhesion of tyres in new state) and R (rolling resistance at stage 2) The "03B" preceded by "+" indicates that it has had its approval extended under UN Regulation No. 117 and 03 series of amendments to wet adhesion of tyres in worn state based on separate certificate."

Annex 5, title, amend to read:

"Test procedures for measuring the adhesion on wet surfaces of tyres in new state"

Annex 5 – Appendix, amend to read:

"Test reports examples of wet grip index for tyres in new state"

Example 1: Test report of wet grip index for tyres in new state using trailer or tyre test vehicle method

...

Example 2: Test report of wet grip index for tyres in new state using vehicle method

..."

Annex 7,

Appendix 3, Part I, paragraph 7., amend to read:

"7. Snow grip index relative to SRTT according to paragraph 6.5.1.1."

Insert a new Annex 9, to read:

"Annex 9

Test procedure for measuring the adhesion on wet surfaces of tyres in worn state

1. General part (reserved)
2. Tyres of class C1
Principle
Two steps:
 - 1) Preparation of the tyre in worn state
 - 2) Wet grip index evaluation of the tyre in worn state
- 2.1. Definitions

For the purpose of this Annex, the "Candidate tyre" or "Candidate tyre set" and the "Reference tyre" or "Reference tyre set" mentioned in paragraphs 2.19.2. and 2.19.3. shall be read respectively as "Candidate tyre in worn state" or "Candidate tyre set in worn state" and the "Reference tyre in worn state" or "Reference tyre set in worn state".

- 2.1.1. "Tyre in worn state" or "worn tyre" means, for the purpose of this Regulation, a new tyre artificially worn by reducing the tread depth at the height of the tread-wear indicator as defined in the UN Regulation No. 30 (1.6 +0.6 / -0.0 mm).
- 2.1.2. "Tyre in new state" means a new tyre before starting to be artificially worn.
- 2.1.3. "Groove" means the space between two adjacent ribs or blocks in the tread pattern.
- 2.1.4. "Groove depth" means the perpendicular distance from a real or calculated reference plane defined by edges of two adjacent ribs to the lowest point in the groove.
- 2.1.5. "Reference tread width" (C) is calculated as follows:
- $$C = (1.075 - 0.005 \cdot Ra) \cdot S_1^{1.001}$$
- Where:
- Ra is the nominal aspect ratio as defined as part of tyre size designation in UN Regulation No. 30 except for the sizes listed in Annex 5 of UN Regulation No. 30 where it is taken as 90 and
- S_1 is the nominal section width according to UN Regulation No. 30 except for the sizes listed in Annex 5 of UN Regulation No. 30 where it is the tyre section width listed therein.
- 2.1.6. "Tread-wear indicators": see definition in UN Regulation No. 30.
- 2.1.7. "Centre line" means the line dividing the overall width of the tyre in two equal parts.
- 2.1.8. "Central zone" means the area on the tread width defined by the $\frac{3}{4}$ (75%) of the reference tread width (C) symmetrically measured from the centre line.
- 2.1.9. "Shoulder zone" means the area on both sides of the tread outside of the central zone.
- 2.1.10. "Mould parting line" means the border circumference in which mould tread pattern segments connects with mould sidewall plates. If no mould parting line is visible on the tyre, a virtual mould parting line shall be considered as the circumferential line in the equivalent position at the end of the shoulder grooves.
- 2.1.11. "Tread pattern limit points Li and Le " means the points located on the tyre profile between mould parting line and hypothetical point up to 15 mm on the tyre profile towards centre line (see Figure 1).



Figure 1

- 2.1.12. "Buffing" is all the processes of removing material from the tread to prepare the tyre in worn state for following the procedure in paragraph 2.2.1.
- 2.1.13. "Reference tyre in worn state" or "Reference tyre set in worn state" means a tyre or a tyre set of Standard Reference Test Tyres SRTT16 in worn state.
- 2.2. Theoretical target profile of a tyre at worn state
- The theoretical target profile is the profile curve of the tyre in worn state, as described in paragraph 2.2.1.2.2.
- 2.2.1. Preparation of class C1 tyres in worn state
- The following paragraphs outline the preparation of worn tyres of class C1 by removal of a predetermined amount of tread rubber (for example cutting, grinding, surface finish) for subsequent wet grip index testing.
- 2.2.1.1. Apparatus
- 2.2.1.1.1. *Tread Depth Gauge.*
- Any mechanical, optical, or electronic device capable of measuring groove (void) depth can be used. The resolution of the gauge shall be at least 0.02 mm. The accuracy of the gauge shall be to within ± 0.04 mm.
- 2.2.1.1.2. *Tyre Tread Removal Machine*, with equipment to remove tread rubber in a predetermined manner. Specifically, the equipment shall ensure a buffing accuracy and precision on the final groove depth as required in the paragraph 2.2.1.2.4.1.
- 2.2.1.2. Procedure
- Choose 4 positions approximately equally spaced around the circumference.



Figure 2

At each of the four positions, choose measurement points in the transversal direction:

- In the central zone pursuant to the procedure described in paragraph 2.2.1.2.1. and
 - In each shoulder zone at least one measurement point.
- 2.2.1.2.1. *Choice of the control measurement points of the central zone*
- To control the conformity of the preparation process (see paragraph 2.2.1.2.3., choose n measurement points in the central zone, in the transversal direction (see Figure 2)
- The number of measurement points n shall be greater than or equal to 4; */
 - 1 measurement point in each principal groove;
 - The other measurement points shall be located in non-principal grooves:
 - At the maximum groove depth in the corresponding groove/zone;
 - In order to have the most regular distribution of the n points.

*/ In case a tyre tread pattern does not allow the measurement at 4 points in the central zone, the groove depth may be measured at 3 measurement points. In case that 3 measurement points in transversal direction are not available, the number and position of the measurement points shall be agreed with the Type Approval Authority.

Measurement points in the principal grooves shall be positioned at locations with full groove depth, for example, avoiding rubber ridges, tie bars, treadwear indicators and other elevated elements.

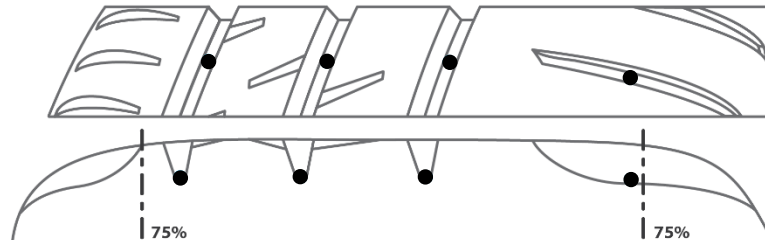

Figure 3

2.2.1.2.2. Description of theoretical worn target profile

Central zone: curve built on a circle with its centre located on the radial axle passing through the centre line and its radius built on a fit on all the points located at 2 mm height on all the control points as described in paragraph 2.2.1.2.1. Alternatively, depending of the specificity of the tread pattern geometry, the fitting curve can be the offset of the original tyre profile.

Shoulder zone: edges of the artificial worn profile in the central part of the tread are connected with L_e and L_i points. Regularity of the whole artificial worn tyre profile (on the of the central zone to the shoulders) shall be assured (for example by an arc of circumference or another curve).

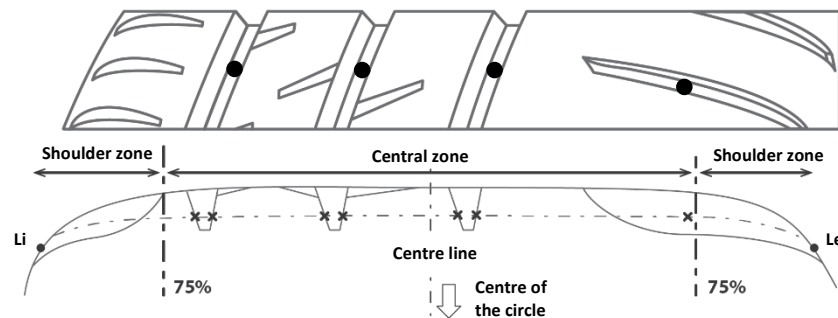

Figure 4

2.2.1.2.3. Preparation of the worn tyre.

Inspect the tyre to determine that there are no tread defects that would affect the finished tyre. If such conditions are noted, do not use the tyre for this procedure.

Depending on the worn tyre preparation processing technique, the removing of the rubber can be managed by directly targeting the worn tyre target profile, or by a manual regular controlling of the rubber removal, or other means.

2.2.1.2.4. Validation of the prepared tyre

2.2.1.2.4.1. Validation of tread depths

At the end of the preparation process, measure the groove depth at the measurement points defined in paragraph 2.2.1.2.1.

For all the measurement points defined in the central zone:

- The final groove depth at each individual measurement point of the central zone shall be $2 \text{ mm} \pm 0.4 \text{ mm}$
- The average groove depth over all measurement points in the central zone shall be $2 \text{ mm} \pm 0.2 \text{ mm}$

For each measurement point defined in the shoulder zone:

- The final groove depth in the shoulder zone shall not be greater than 2 mm.

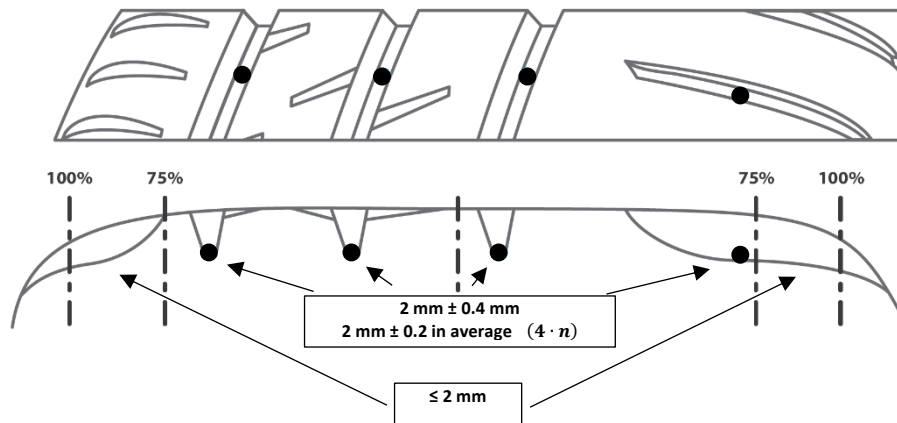

Figure 5

If one of the above conditions is not met, another candidate tyre shall be prepared.

2.2.1.2.4.2. Validation of the surface of the worn tyre

The arithmetical mean height of the absolute values of the roughness profile, as defined in ISO 21920-2:2021, of the final surface shall be determined at 3 measurement points in the transversal direction approximately equally spaced on the prepared surface, at 4 circumferential positions equally spaced.

The average of the 3 arithmetical mean height of the absolute values of the roughness profile of the final surface shall not exceed $20 \mu\text{m}$.

If the above condition is not met, another candidate tyre shall be prepared.

2.3. General test conditions

2.3.1. Track characteristics

The test track shall have the following characteristics:

- 2.3.1.1. The surface shall have a dense asphalt surface with a uniform gradient of not more than 2 per cent in both longitudinal and lateral directions and shall not deviate more than 6 mm when tested with a 3 m straight edge.
- 2.3.1.2. The surface shall have a pavement of uniform age, composition, and wear. The test surface shall be free of loose material and foreign deposits.
- 2.3.1.3. The maximum chipping size shall be 10 mm (tolerances permitted from 8 mm to 13 mm).
- 2.3.1.4. The average macro texture depth as measured in accordance with ASTM E965-96 (Reapproved 2006) by a sand patch shall be $(0.7 \pm 0.3) \text{ mm}$. In case the vehicle method is used, the average macro texture depth shall be determined in both lanes where the tyres are going to brake.

2.3.1.5. The wetted frictional properties of the surface shall be measured using the ~~Worn~~ Standard Reference Test Tyre SRTT16 in worn state either with the method described in paragraph 2.3.2.1. of this Annex in case the vehicle method (according to paragraph 2.4.1. below) is used, or with the method described in paragraph 2.3.2.2. in this Annex in case the trailer (or tyre test vehicle) method is used.

2.3.2. Methods to measure the wetted frictional properties of the surface

2.3.2.1. Using the procedure described in paragraph 2.4.1. of this Annex, perform two braking tests of the reference tyre, each consisting of at least six (6) valid test runs in the same direction on aligned segments of the track. The braking tests shall cover the entire potential braking area, including where the texture depth was measured.

Evaluate the braking tests as described in paragraphs 2.4.1.1.1. and 2.4.1.1.2. of this Annex. If the coefficient of variation of one braking test CV_{BFC} exceeds 4 per cent, dismiss the results and repeat the braking tests.

For each braking test, the arithmetic mean $\overline{BFC_{ave}}$ of the average Braking Force Coefficients shall be corrected for effects of temperature as follows:

$$BFC_{ave,corr} = \overline{BFC_{ave}} + a \cdot (\vartheta - \vartheta_0)$$

where

ϑ is the wetted surface temperature in degrees Celsius,

$a = 0.002 \text{ } ^\circ\text{C}^{-1}$ and $\vartheta_0 = 20 \text{ } ^\circ\text{C}$.

For each braking test, the temperature-corrected average Braking Force Coefficient ($BFC_{ave,corr}$) shall be not less than 0.4 and not greater than 0.65

The arithmetic means of the temperature-corrected average Braking Force Coefficients of the two braking tests shall not differ by more than 10 per cent of the average of the two values:

$$CV_{al}(BFC_{ave,corr}) = 2 \cdot \left| \frac{BFC_{ave,corr,1} - BFC_{ave,corr,2}}{BFC_{ave,corr,1} + BFC_{ave,corr,2}} \right| \leq 10 \%$$

2.3.2.2. Using the procedure described in paragraph 2.4.2. of this Annex, perform in the same area where the average macro texture depth was measured one braking test of the reference tyre, consisting of at least six (6) test runs in the same direction.

Evaluate the braking test as described in paragraphs 2.4.2.1.1. and 2.4.2.1.2. of this Annex. If the coefficient of variation CV_μ exceeds 4 per cent, dismiss the results and repeat the braking test.

The arithmetic mean ($\overline{\mu_{peak}}$) of the measured peak braking force coefficients shall be corrected for effects of temperature as follows:

$$\mu_{peak,corr} = \overline{\mu_{peak}} + a \cdot (\vartheta - \vartheta_0)$$

Where

ϑ is the wetted road surface temperature in degrees Celsius

$a = 0.002 \text{ } ^\circ\text{C}^{-1}$ and $\vartheta_0 = 20 \text{ } ^\circ\text{C}$.

The temperature corrected average peak braking force coefficient ($\mu_{peak,corr}$) shall be not less than 0.45 and not greater than 0.80.

2.3.3. Atmospheric conditions

The wind conditions shall not interfere with wetting of the surface (wind-shields are allowed).

The wetted surface temperature and the ambient temperature shall be between:

| Category of use | | Wetted surface temperature | Ambient temperature |
|-------------------|--|----------------------------|---------------------|
| Normal tyres | | 12 °C – 35 °C | 12 °C – 40 °C |
| Snow tyres | | 5 °C – 35 °C | 5 °C – 40 °C |
| | Snow tyres for use in severe snow conditions | 5 °C – 20 °C | 5 °C – 20 °C |
| Special use tyres | | not applicable | not applicable |

Moreover, the wetted surface temperature shall not vary during the test by more than 10 °C.

The ambient temperature shall remain close to the wetted surface temperature; the difference between the ambient and the wetted surface temperatures shall be less than 10 °C.

2.3.4. Replacement of reference tyres

When irregular wear or damage results from tests, or when wear or aging influences the test results, the use of the reference tyre shall be discontinued.

2.4. Testing methods for measuring the adhesion on wet surfaces

For the calculation of the wet grip index (G_B) of a candidate tyre in worn state, the wet grip braking performance of the candidate tyre is compared to the wet grip braking performance of the reference tyre on a vehicle travelling straight ahead on a wet, paved surface. It is measured with one of the following methods:

- (a) Vehicle method consisting of testing a set of tyres mounted on an instrumented passenger car;
- (b) Testing method using a trailer towed by a vehicle or a tyre test vehicle, equipped with the test tyre(s).

2.4.1. Testing method (a) using an instrumented passenger car

All the provisions specified in Annex 5, Part (A), paragraph 4.1. "Testing method (a) using an instrumented passenger car" and its subparagraphs apply with the exception of paragraph 4.1.6. "Processing of measurement results". The paragraph 2.4.1.1. of this Annex applies instead.

2.4.1.1. Processing of measurement results

2.4.1.1.1. Calculation of the average braking force coefficient

All the provisions specified in Annex 5, Part (A), paragraph 4.1.6.1. apply.

2.4.1.1.2. Validation of results

The coefficient of variation CV_{BFC} is calculated as follows:

$$CV_{BFC} = 100\% \cdot \frac{\sigma_{BFC}}{\overline{BFC_{ave}}}$$

where

$\sigma_{BFC} = \sqrt{\frac{1}{N-1} \sum_{j=1}^N (BFC_{ave,j} - \overline{BFC_{ave}})^2}$ denotes the corrected sample standard deviation and

$\overline{BFC_{ave}}$ the arithmetic mean of the average braking force coefficients $BFC_{ave,j}$ of N test runs.

For the reference tyre:

- (a) The coefficient of variation CV_{BFC} of the initial and the final braking test of the reference tyre within one test cycle shall be less than or equal to 4 per cent.
- (b) The arithmetic means of the average braking force coefficients of the initial and the final braking test shall not differ by more than [5] per cent of the average of the two values:

$$CV_{BFC}(BFC_{ave}) = 100\% \cdot 2 \cdot \frac{|\overline{BFC_{ave}}(R_i) - \overline{BFC_{ave}}(R_f)|}{|\overline{BFC_{ave}}(R_i) + \overline{BFC_{ave}}(R_f)|} \leq [5]\%$$

where

$\overline{BFC_{ave}}(R_i)$ and $\overline{BFC_{ave}}(R_f)$ are the arithmetic means of the average braking force coefficients respectively in the initial and final braking tests of the reference tyre within a test cycle.

- (c) The temperature-corrected average braking force coefficients ($BFC_{ave,corr}$, see paragraph 2.3.2.1. of this Annex) as calculated from the initial and from the final braking tests of the reference tyre within a test cycle shall be not less than 0.40 and not greater than 0.65.

If one or more of the above conditions is not met, the complete test cycle shall be performed again.

For the candidate tyres (T):

The coefficient of variation CV_{BFC} is calculated for each candidate tyre set. If one coefficient of variation is higher than 4 per cent, the data shall be discarded and the braking test repeated for that candidate tyre set.

2.4.1.1.3. Calculation of adjusted average braking force coefficient

All the provisions specified in Annex 5, Part (A), paragraph 4.1.6.3. apply.

2.4.1.1.4. Calculation of the wet grip index of the candidate tyre

The wet grip index $G_B(T_n)$ of the candidate tyre T_n ($n = 1, 2$ or 3) is calculated as follows:

$$G_B(T_n) = K_{vehicle} \cdot \{\overline{BFC_{ave}}(T_n) - [a \cdot \Delta BFC(R) + b \cdot \Delta\vartheta + c \cdot (\Delta\vartheta)^2 + d \cdot \Delta MTD]\}$$

where:

$\overline{BFC_{ave}}(T_n)$ is the arithmetic mean of the average braking force coefficients of the candidate tyre T_n within a braking test;

$$\Delta BFC(R) = BFC_{adj}(R) - BFC(R_0)$$

$BFC_{adj}(R)$ is the adjusted average braking force coefficient in accordance with Table 1;

$BFC(R_0) = 0.52$ is fixed as the braking force coefficient for the reference tyre in the reference conditions;

$$\Delta\vartheta = \vartheta - \vartheta_0$$

ϑ is the measured wet surface temperature in degrees Celsius when the candidate tyre T_n is tested;

ϑ_0 is the wetted surface reference temperature for the candidate tyre according to its category of use as listed in Table 2;

$$\Delta MTD = MTD - MTD_0$$

MTD is the measured macro texture depth in mm of the track (see paragraph 3.1.4. of this Annex);

$MTD_0 = 0.8$ mm is the macro texture depth of the reference track;

$K_{\text{vehicle}} = 1.95$ is a factor to grant consistency between previous calculation of the wet grip index and this one, and to ensure convergence between vehicle and trailer method and

coefficients a , b , c and d are given in Table 2.

Table 2

| Category of use | ϑ_0 (°C) | a | b (°C ⁻¹) | c (°C ⁻²) | d (mm ⁻¹) |
|---|-----------------------|----------|----------------------------|----------------------------|----------------------------|
| Normal tyre | 20 | +0.90996 | -0.00179 | -0.00013 | -0.10313 |
| Snow tyre | 15 | +0.81045 | -0.00004 | -0.00019 | -0.05093 |
| Snow tyre for use in severe snow conditions | 10 | +0.71094 | +0.00172 | -0.00025 | +0.00127 |
| Special use tyre | not defined | | | | |

2.4.2. Testing method (b) using a trailer towed by a vehicle or a tyre test vehicle

All the provisions specified in Annex 5, Part (A), paragraph 4.2. "Testing method (b) using a trailer towed by a vehicle or a tyre test vehicle" and its subparagraphs apply with the exception of paragraph 4.2.8. "Processing of measurement results". The paragraph 2.4.2.1. of this Annex applies instead.

2.4.2.1. Processing of measurement results

2.4.2.1.1. Calculation of the peak braking force coefficient

All the provisions specified in Annex 5, Part (A), paragraph 4.2.8.1. apply.

2.4.2.1.2. Validation of results

The μ_{peak} coefficient of variation CV_{μ} is calculated as follows:

$$CV_{\mu} = 100\% \cdot \frac{\sigma_{\mu}}{\mu_{\text{peak}}}$$

where

$\sigma_{\mu} = \sqrt{\frac{1}{N-1} \sum_{j=1}^N (\mu_{\text{peak},j} - \overline{\mu_{\text{peak}}})^2}$ denotes the corrected sample standard deviation and

$\overline{\mu_{\text{peak}}}$ the arithmetic mean of the peak braking force coefficients ($\mu_{\text{peak},j}$) of N test runs.

For the reference tyre (R):

- (a) The coefficients of variation CV_{μ} of the initial and the final braking tests of the reference tyre within one test cycle shall be less than or equal to 4 per cent;
- (b) The arithmetic mean of the peak braking force coefficients of initial and the final braking test of the reference tyre within one test cycle shall not differ by more than 5 per cent of the average of the two values:

$$CV_{\text{val}}(\mu_{\text{peak}}) = 100\% \cdot 2 \cdot \frac{|\overline{\mu_{\text{peak}}}(\text{R}_i) - \overline{\mu_{\text{peak}}}(\text{R}_f)|}{\overline{\mu_{\text{peak}}}(\text{R}_i) + \overline{\mu_{\text{peak}}}(\text{R}_f)} \leq 5\%$$

where

$\overline{\mu_{\text{peak}}}(\text{R}_i)$ and $\overline{\mu_{\text{peak}}}(\text{R}_f)$ are the arithmetic means of the peak braking force coefficients respectively in the initial and final braking tests of the reference tyre within a test cycle;

- (c) The temperature-corrected average peak braking force coefficients ($\mu_{\text{peak,corr}}$, see paragraph 2.3.2.2. of this Annex) as calculated from the

initial and from the final braking test of the reference tyre within a test cycle shall be not less than 0.45 and not greater than 0.80.

If one or more of the above conditions is not met, the complete test cycle shall be performed again.

For the candidate tyre(s) (T_n):

The coefficient of variation of the peak braking force coefficient CV_μ is calculated for each candidate tyre. If one coefficient of variation is greater than 5 per cent, the data shall be discarded and the braking test repeated for this candidate tyre.

- 2.4.2.1.3. Calculation of the adjusted average peak braking force coefficient of the reference tyre

All the provisions specified in Annex 5, Part (A), paragraph 4.2.8.3. apply.

- 2.4.2.1.4. Calculation of the wet grip index of the candidate tyre

The wet grip index $G_B(T_n)$ of the candidate tyre T_n ($n = 1, 2, 3$) is calculated as follows:

$$G_B(T_n) = K_{\text{trailer}} \cdot \{ \overline{\mu_{\text{peak}}}(T_n) - [a \cdot \Delta\mu_{\text{peak}}(R) + b \cdot \Delta\vartheta + c \cdot (\Delta\vartheta)^2 + d \cdot \Delta MTD] \}$$

where:

$\overline{\mu_{\text{peak}}}(T_n)$ is the arithmetic mean of the peak braking force coefficients of the candidate tyre T_n within a braking test;

$$\Delta\mu_{\text{peak}}(R) = \mu_{\text{peak,adj}}(R) - \mu_{\text{peak}}(R_0)$$

$\mu_{\text{peak,adj}}(R)$ is the adjusted peak braking force coefficient in accordance with Table 3;

$\mu_{\text{peak}}(R_0) = 0.71$ is fixed as the peak braking force coefficient for the reference tyre in the reference conditions;

$$\Delta\vartheta = \vartheta - \vartheta_0$$

ϑ is the measured wet surface temperature in degrees Celsius when the candidate tyre T_n is tested;

ϑ_0 is the wetted surface reference temperature for the candidate tyre according to its sidewall marking as listed in Table 4;

$$\Delta MTD = MTD - MTD_0$$

MTD is the measured macro texture depth of the track

$MTD_0 = 0.8$ mm is fixed as the macro texture depth of the reference track;

$K_{\text{trailer}} = 1.50$ is a factor to grant consistency between previous calculation of the wet grip index and this one, and to ensure convergence between vehicle and trailer method and

coefficients a , b , c and d are given in Table 4.

Table 4

| Category of use | ϑ_0 (°C) | a | b (°C ⁻¹) | c (°C ⁻²) | d (mm ⁻¹) |
|---|-----------------------|----------|----------------------------|----------------------------|----------------------------|
| Normal tyre | 20 | +0.99655 | -0.00124 | +0.00041 | +0.06876 |
| Snow tyre | 15 | +0.94572 | -0.00032 | -0.00020 | +0.08047 |
| Snow tyre for use in severe snow conditions | 10 | +0.89488 | +0.00061 | -0.00080 | +0.09217 |
| Special use tyre | not defined | | | | |

”

Insert a new Annex 9 – Appendix 1, to read:

“Annex 9 – Appendix 1

Worn tyre preparation report example

| | |
|-----------------------------------|--|
| Date of buffing | |
| Manufacturer | |
| Brand | |
| Trade description/commercial name | |
| Size | |
| Service description | |
| Rim width | |
| Inflation pressure (kPa) | |
| Week of manufacture | |
| Tyre identification code | |

Groove depth measurement

| Groove depth Central zone: (2.0 ± 0.4) mm Shoulder zone: ≤ 2 mm | in central zone (yes/no) | Circumferential locations | | | |
|--|-----------------------------|---------------------------|---|---|---|
| | | 1 | 2 | 3 | 4 |
| Transversal locations | 1 | | | | |
| | 2 | | | | |
| | 3 | | | | |
| | 4 | | | | |
| | 5 | | | | |
| | 6 | | | | |
| | 7 | | | | |
| | 8 | | | | |

| |
|---------------|
| <i>Values</i> |
|---------------|

| | |
|---|--|
| Average groove depth in central zone (mm) | |
| Central zone: (2.0 ± 0.2) mm | |

Roughness measurement

| Arithmetical mean height of the absolute values of the roughness profile (μm) | | Sections | | | |
|--|------------|----------|---|---|---|
| | | 1 | 2 | 3 | 4 |
| Trans. Loc. | 1 (right) | | | | |
| | 2 (center) | | | | |
| | 3 (left) | | | | |
| Average | | | | | |

| | |
|--|--|
| Average of the arithmetical mean height of the absolute values of the roughness profiles (μm) | |
|--|--|

”

Insert a new Annex 9 – Appendix 2, to read:

"Annex 9 – Appendix 2

Test reports examples of wet grip index for tyres in worn state

Example 1: Test report of wet grip index for tyres in worn state using trailer or tyre test vehicle method

| | | | |
|---------------------|--|------------|--|
| Test report number: | | Test date: | |
|---------------------|--|------------|--|

| | | | |
|---------------------|--|----------------------------|----------|
| Track: | | Minimum: | Maximum: |
| Texture depth (mm): | | Wetted surface temp. (°C): | |
| $\mu_{peak,corr}$: | | Ambient temp (°C): | |
| Water depth (mm): | | | |

| | |
|---------------|--|
| Speed (km/h): | |
|---------------|--|

| No. | 1 | 2 | 3 | 4 | 5 |
|---|---------|---|---|---|---------|
| Brand | | | | | |
| Pattern/trade description | SRTT... | | | | SRTT... |
| Size | | | | | |
| Service description | | | | | |
| Reference (test) inflation pressure (kPa) | | | | | |
| Tyre identification | | | | | |
| M+S marking (Y/N) | | | | | |
| 3PMSF marking (Y/N) | | | | | |
| Rim | | | | | |
| Load (kg) | | | | | |
| Pressure (kPa) | | | | | |
| μ_{peak} | 1 | | | | |
| | 2 | | | | |
| | 3 | | | | |
| | 4 | | | | |
| | 5 | | | | |
| | 6 | | | | |
| | 7 | | | | |
| | 8 | | | | |
| $\overline{\mu_{peak}}$ | | | | | |
| Standard deviation, σ_{μ} | | | | | |
| $CV_{\mu} \leq 4 \%$ | | | | | |
| $CVal(\mu_{peak}) \leq 5 \%$ | | | | | |

| No. | 1 | 2 | 3 | 4 | 5 |
|------------------------------------|---|---|---|---|---|
| $\mu_{\text{peak,corr}}(\text{R})$ | | | | | |
| $\mu_{\text{peak,adj}}(\text{R})$ | | | | | |
| Wet grip index | | | | | |
| Wetted surface temp. (°C) | | | | | |
| Ambient temp. (°C) | | | | | |
| Remarks | | | | | |

Example 2: Test report of wet grip index for tyres in worn state using vehicle method

Test report number:

Test date:

| | |
|---------------------------------|--|
| Track: | |
| Texture depth (mm): | |
| $BFC_{\text{ave,corr},1}$: | |
| $BFC_{\text{ave,corr},2}$: | |
| $CVal(BFC_{\text{ave,corr}})$: | |
| Water depth (mm): | |

| | Minimum: | Maximum: |
|----------------------------|----------|----------|
| Wetted surface temp. (°C): | | |
| Ambient temp (°C): | | |
| | | |
| | | |

| | |
|-----------------------|------------|
| Vehicle | |
| Brand: | |
| Model: | |
| Type: | |
| Year of registration: | |
| Maximum axle load: | Front Rear |

Initial speed (km/h):

Final speed (km/h):

| No. | 1 | 2 | 3 | 4 | 5 | | | | | |
|---|-----------------------------|------------------------|-----------------------------|------------------------|-----------------------------|------------------------|-----------------------------|------------------------|-----------------------------|------------------------|
| Brand | | | | | | | | | | |
| Pattern/trade description | SRTT... | | | | SRTT... | | | | | |
| Size | | | | | | | | | | |
| Service description | | | | | | | | | | |
| Reference (test) inflation pressure (kPa) | | | | | | | | | | |
| Tyre identification | | | | | | | | | | |
| M+S marking (Y/N) | | | | | | | | | | |
| 3PMSF marking (Y/N) | | | | | | | | | | |
| Rim | | | | | | | | | | |
| Front axle pressure (kPa) | left: right: | left: right: | left: right: | left: right: | left: right: | | | | | |
| Rear axle pressure (kPa) | left: right: | left: right: | left: right: | left: right: | left: right: | | | | | |
| Front axle load (kg) | left: right: | left: right: | left: right: | left: right: | left: right: | | | | | |
| Rear axle load (kg) | left: right: | left: right: | left: right: | left: right: | left: right: | | | | | |
| | <i>Braking distance (m)</i> | <i>BFC_i</i> | <i>Braking distance (m)</i> | <i>BFC_i</i> | <i>Braking distance (m)</i> | <i>BFC_i</i> | <i>Braking distance (m)</i> | <i>BFC_i</i> | <i>Braking distance (m)</i> | <i>BFC_i</i> |
| Measurement | 1 | | | | | | | | | |
| | 2 | | | | | | | | | |
| | 3 | | | | | | | | | |
| | 4 | | | | | | | | | |
| | 5 | | | | | | | | | |
| | 6 | | | | | | | | | |

| No. | | 1 | 2 | 3 | 4 | 5 |
|---------------------------------------|----|---|---|---|---|---|
| | 7 | | | | | |
| | 8 | | | | | |
| | 9 | | | | | |
| | 10 | | | | | |
| \overline{BFC}_{ave} | | | | | | |
| Standard deviation, σ_{BFC} | | | | | | |
| $CV_{BFC} \leq 4 \%$ | | | | | | |
| $CVal(BFC_{ave}) \leq 5 \%$ | | X | X | X | X | X |
| $BFC_{ave,corr}(R)$ | | X | X | X | X | X |
| $BFC_{adj}(R)$ | | X | X | X | X | X |
| Wet grip index | | X | X | X | X | X |
| Wetted surface temp. (°C) | | | | | | |
| Ambient temp. (°C) | | | | | | |
| Remarks | | | | | | |

"

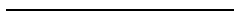

16 February 2016

Agreement

Concerning the Adoption of Uniform Technical Prescriptions for Wheeled Vehicles, Equipment and Parts which can be Fitted and/or be Used on Wheeled Vehicles and the Conditions for Reciprocal Recognition of Approvals Granted on the Basis of these Prescriptions*

(Revision 2, including the amendments which entered into force on 16 October 1995)

Addendum 116: Regulation No. 117

Revision 4

Incorporating all valid text up to:

Corrigendum 4 to 02 series of amendments – Date of entry into force: 12 March 2014

Corrigendum 5 to 02 series of amendments (*Russian only*) – Date of entry into force: 12 March 2014

Supplement 5 to the 02 series of amendments – Date of entry into force: 10 June 2014

Supplement 6 to the 02 series of amendments – Date of entry into force: 9 October 2014

Supplement 7 to the 02 series of amendments – Date of entry into force: 8 October 2015

Supplement 8 to the 02 series of amendments – Date of entry into force: 20 January 2016

Uniform provisions concerning the approval of tyres with regard to rolling sound emissions and/or to adhesion on wet surfaces and/or to rolling resistance

This document is meant purely as documentation tool. The authentic and legal binding texts of the supplements and the corrigenda are listed on the following page.



UNITED NATIONS

* Former title of the Agreement:

Agreement Concerning the Adoption of Uniform Conditions of Approval and Reciprocal Recognition of Approval for Motor Vehicle Equipment and Parts, done at Geneva on 20 March 1958.

The authentic and legal binding texts of the supplements and the corrigenda are:

- ECE/TRANS/WP.29/2013/59
- ECE/TRANS/WP.29/2014/4
- ECE/TRANS/WP.29/2014/6
- ECE/TRANS/WP.29/2013/66 (as amended by paragraph 56 of the report ECE/TRANS/WP.29/1108)
- ECE/TRANS/WP.29/2015/5
- ECE/TRANS/WP.29/2015/65 (as amended by paragraph 66 of the report ECE/TRANS/WP.29/1116).

Regulation No. 117

Uniform provisions concerning the approval of tyres with regard to rolling sound emissions and/or to adhesion on wet surfaces and/or to rolling resistance

Contents

| | <i>Page</i> |
|--|-------------|
| Regulation | |
| 1. Scope | 5 |
| 2. Definitions | 5 |
| 3. Application for approval | 9 |
| 4. Markings | 11 |
| 5. Approval | 11 |
| 6. Specifications | 13 |
| 7. Modifications of the type of pneumatic tyre and extension of approval | 18 |
| 8. Conformity of production | 18 |
| 9. Penalties for non-conformity of production | 19 |
| 10. Production definitively discontinued | 19 |
| 11. Names and addresses of Technical Services responsible for conducting approval tests of Type Approval Authorities | 20 |
| 12. Transitional provisions | 20 |
| Annexes | |
| 1 Communication | 22 |
| 2 Appendix 1 - Example of approval marks | 24 |
| Appendix 2 - Approval according to Regulation No. 117 coincident with approval of Regulation No. 30 or 54 | 25 |
| Appendix 3 - Extensions to combine approvals issued in accordance with Regulations Nos. 117, 30 or 54 | 28 |
| Appendix 4 - Extensions to combine approvals issued in accordance with Regulation No. 117 | 29 |
| 3 Coast-by test method for measuring tyre-rolling sound emission | 31 |
| Appendix 1 - Test report | 38 |
| 4 Specifications for the test site | 40 |
| 5 Test procedures for measuring wet grip | 47 |
| Appendix - Test reports examples of wet grip index | 73 |

| | | |
|---|--|-----|
| 6 | Test procedure for measuring rolling resistance | 75 |
| | Appendix 1 - Test equipment tolerances | 86 |
| | Appendix 2 - Measuring rim width..... | 89 |
| | Appendix 3 - Test report and test data (Rolling resistance) | 90 |
| | Appendix 4 - Tyre standards organizations | 91 |
| | Appendix 5 - Deceleration method: Measurements and data processing for deceleration value obtaining in differential form $d\omega/dt$ | 92 |
| 7 | Procedures for snow performance testing relative to snow tyre for use in severe snow conditions ... | 95 |
| | Appendix 1 - Pictogram definition of "Alpine Symbol" | 107 |
| | Appendix 2 - Test reports and test data for C1 and C2 tyres | 108 |
| | Appendix 3 - Test reports and test data for C3 tyres..... | 110 |

1. Scope

- 1.1. This Regulation applies to new pneumatic tyres of Classes C1, C2 and C3 with regard to their sound emissions, rolling resistance and to adhesion performance on wet surfaces (wet adhesion). It does not, however, apply to:
 - 1.1.1. Tyres designed as "Temporary use spare tyres" and marked "Temporary use only";
 - 1.1.2. Tyres having a nominal rim diameter code ≤ 10 (or ≤ 254 mm) or ≥ 25 (or ≥ 635 mm);
 - 1.1.3. Tyres designed for competitions;
 - 1.1.4. Tyres intended to be fitted to road vehicles of categories other than M, N and O;¹
 - 1.1.5. Tyres fitted with additional devices to improve traction properties (e.g. studded tyres);
 - 1.1.6. Tyres with a speed rating less than 80 km/h (speed symbol F);
 - 1.1.7. Tyres designed only to be fitted to vehicles registered for the first time before 1 October 1990.
 - 1.1.8. Professional off-road tyres.
- 1.2. Contracting Parties shall issue or accept approvals to rolling sound and/or wet adhesion and/or rolling resistance.

2. Definitions

For the purpose of this Regulation, in addition to the definitions contained in Regulations Nos. 30 and 54, the following definitions apply.

- 2.1. "*Type of tyre*" means, in relation to this Regulation, a range of tyres consisting of a list of tyre size designations, brand names and trade descriptions, which do not differ in such essential characteristics as:
 - (a) The manufacturer's name;
 - (b) The tyre class (see paragraph 2.4. below);
 - (c) The tyre structure;
 - (d) The category of use: normal tyre, snow tyre and special use tyre;
 - (e) For Class C1 tyres:
 - (i) In case of tyres submitted for approval of rolling sound emission levels, whether normal or reinforced (or extra load);

¹ As defined in the Consolidated Resolution on the Construction of Vehicles (R.E.3), document ECE/TRANS/WP.29/78/Rev.4, para. 2. - www.unece.org/trans/main/wp29/wp29wgs/wp29gen/wp29resolutions.html

- (ii) In case of tyres submitted for approval of performance adhesion on wet surfaces, whether normal tyres or snow tyres with a speed category of Q or below excluding H (≤ 160 km/h) or speed category R and above including H (> 160 km/h);
 - (f) For Classes C2 and C3 tyres:
 - (i) In case of tyres submitted for approval of rolling sound emission levels at stage 1, whether M+S marked or not;
 - (ii) In case of tyres submitted for approval of rolling sound emission levels at stage 2, whether traction tyre or not;
 - (g) The tread pattern (see paragraph 3.2.1. of this Regulation).
- 2.2. "*Brand name*" or "*Trade description*" means the identification of the tyre as given by the tyre manufacturer. The brand name may be the same as that of the manufacturer and the trade description may coincide with the trade mark.
- 2.3. "*Rolling sound emission*" means the sound emitted from the contact between the tyres in motion and the road surface.
- 2.4. "*Tyre class*" means one of the following groupings:
- 2.4.1. *Class C1 tyres*: Tyres conforming to Regulation No. 30;
- 2.4.2. *Class C2 tyres*: Tyres conforming to Regulation No. 54 and identified by a load capacity index in single formation lower or equal to 121 and a speed category symbol higher or equal to "N";
- 2.4.3. *Class C3 tyres*: Tyres conforming to Regulation No. 54 and identified by:
- (a) A load capacity index in single formation higher or equal to 122; or
 - (b) A load capacity index in single formation lower or equal to 121 and a speed category symbol lower or equal to "M".
- 2.5. "*Representative tyre size*" means the tyre size which is submitted to the test described in Annex 3 to this Regulation with regard to rolling sound emissions, or Annex 5 for adhesion on wet surfaces or Annex 6 for rolling resistance to assess the conformity for the type approval of the type of tyre, or Annex 7 for use in severe snow conditions.
- 2.6. "*Temporary-use spare tyre*" means a tyre different from a tyre intended to be fitted to any vehicle for normal driving conditions; but intended only for temporary use under restricted driving conditions.
- 2.7. "*Tyres designed for competition*" means tyres intended to be fitted to vehicles involved in motor sport competition and not intended for non-competitive on-road use.
- 2.8. "*Normal tyre*" means a tyre intended for normal on-road use.
- 2.9. "*Reinforced tyre*" or "*extra load tyre*" of Class C1 means a pneumatic-tyre structure designed to carry more load at a higher inflation pressure than the load carried by the corresponding standard version tyre at the standard inflation pressure as specified in ISO 4000-1:2010.²

² Class C1 tyres correspond to "passenger car tyres" in ISO 4000-1:2010.

- 2.10. "*Traction tyre*" means a tyre in Class C2 or C3 bearing the inscription TRACTION and intended to be fitted primarily to the drive axle(s) of a vehicle to maximize force transmission in various circumstances.
- 2.11. "*Snow tyre*" means a tyre whose tread pattern, tread compound or structure is primarily designed to achieve in snow conditions a performance better than that of a normal tyre with regard to its ability to initiate or maintain vehicle motion.
- 2.11.1. "*Snow tyre for use in severe snow conditions*" means a snow tyre whose tread pattern, tread compound or structure is specifically designed to be used in severe snow conditions and that fulfils the requirements of paragraph 6.4. of this Regulation.
- 2.12. "*Special use tyre*" means a tyre intended for mixed use both on- and off-road or for other special duty. These tyres are primarily designed to initiate and maintain the vehicle in motion in off-road conditions.
- 2.13. "*Professional off-road tyre*" is a special use tyre primarily used for service in severe off-road conditions.
- 2.14. "*Tread depth*" means the depth of the principal grooves.
- 2.14.1. "*Principal grooves*" means the wide circumferential grooves positioned in the central zone of the tyre tread, which, in the case of passenger and light truck (commercial) tyres, have the treadwear indicators located in the base.
- 2.15. "*Void to fill ratio*" means the ratio between the area of voids in a reference surface and the area of this reference surface calculated from the mould drawing.
- 2.16. "*Standard Reference Test Tyre (SRTT)*" means a tyre that is produced, controlled and stored in accordance with the American Society for Testing and Materials (ASTM) standards
- (a) E1136-93 (2003) for the size P195/75R14
 - (b) F2872 (2011) for the size 225/75 R 16 C
 - (c) F2871 (2011) for the size 245/70R19.5
 - (d) F2870 (2011) for the size 315/70R22.5.
- 2.17. Wet grip or snow grip measurements – Specific definitions
- 2.17.1. "*Adhesion on wet surfaces*" means the relative braking performance, on a wet surface, of a test vehicle equipped with the candidate tyre in comparison to that of the same test vehicle equipped with a reference tyre (SRTT).
- 2.17.2. "*Candidate tyre*" means a tyre, representative of the type that is submitted for approval in accordance with this Regulation.
- 2.17.3. "*Control tyre*" means a normal production tyre that is used to establish the wet grip or snow grip performance of tyre sizes unable to be fitted to the same vehicle as the standard reference test tyre – see paragraph 4.1.7. of Annex 5 and paragraph 3.4.3. of Annex 7 to this Regulation.
- 2.17.4. "*Wet grip index ("G")*" means the ratio between the performance of the candidate tyre and the performance of the standard reference test tyre.

- 2.17.5. "Snow grip index ("SG")" means the ratio between the performance of the candidate tyre and the performance of the standard reference test tyre.
- 2.17.6. "Peak brake force coefficient ("pbfc")" means the maximum value of the ratio of braking force to vertical load on the tyre prior to wheel lock-up.
- 2.17.7. "Mean fully developed deceleration ("mfdd")" means the average deceleration calculated on the basis of the measured distance recorded when decelerating a vehicle between two specified speeds.
- 2.17.8. "Coupling (hitch) height" means the height when measured perpendicularly from the centre of the articulation point of the trailer towing coupling or hitch to the ground, when the towing vehicle and trailer are coupled together. The vehicle and trailer shall be standing on level pavement surface in its test mode complete with the appropriate tyre(s) to be used in the particular test.
- 2.18. Rolling resistance measurement - Specific definitions
- 2.18.1. Rolling resistance F_r
Loss of energy (or energy consumed) per unit of distance traveled.³
- 2.18.2. Rolling resistance coefficient C_r
Ratio of the rolling resistance to the load on the tyre.⁴
- 2.18.3. New test tyre
A tyre which has not been previously used in a rolling deflected test that raises its temperature above that generated in rolling resistance tests, and which has not previously been exposed to a temperature above 40 °C.^{5,6}
- 2.18.4. Laboratory control tyre
Tyre used by an individual laboratory to control machine behaviour as a function of time.⁷
- 2.18.5. Capped inflation
Process of inflating the tyre and allowing the inflation pressure to build up, as the tyre is warmed up while running.
- 2.18.6. Parasitic loss
Loss of energy (or energy consumed) per unit distance excluding internal tyre losses, attributable to aerodynamic loss of the different rotating elements of the test equipment, bearing friction and other sources of systematic loss which may be inherent in the measurement.

³ The International System of Units (SI) unit conventionally used for the rolling resistance is the newton-meter per meter, which is equivalent to a drag force in newton.

⁴ The rolling resistance is expressed in newton and the load is expressed in kilo-newton. The rolling resistance coefficient is dimensionless.

⁵ New test tyre definition is needed to reduce potential data variation and dispersion due to tyre aging effects.

⁶ It is permissible to repeat an accepted test procedure.

⁷ An example of machine behaviour is drift.

- 2.18.7. Skim test reading
Type of parasitic loss measurement, in which the tyre is kept rolling without slippage, while reducing the tyre load to a level at which energy loss within the tyre itself is virtually zero.
- 2.18.8. Inertia or moment of inertia.
Ratio of the torque applied to a rotating body to the rotational acceleration of this body.⁸
- 2.18.9. Measurement reproducibility σ_m
Capability of a machine to measure rolling resistance.⁹

3. Application for approval

- 3.1. The application for approval of a type of tyre with regard to this Regulation shall be submitted by the tyre manufacturer or by his duly accredited representative. It shall specify:
- 3.1.1. The performance characteristics to be assessed for the tyre type; "rolling sound emissions level" and/or "adhesion performance level on wet surfaces" and/or "rolling resistance level". Tyre "snow performance level" in cases of "snow tyre for use in severe snow conditions";
- 3.1.2. Name of manufacturer;
- 3.1.3. Name and address of applicant;
- 3.1.4. Address(es) of manufacturing plant(s);
- 3.1.5. Brand name(s), trade description(s), trade mark(s);
- 3.1.6. Tyre class (Class C1, C2 or C3) (see paragraph 2.4. of this Regulation);
- 3.1.6.1. Section width range for Class C1 tyres (see paragraph 6.1.1. of this Regulation);
- Note:* This information is required only for approval with regard to rolling sound emission level.

⁸ The rotating body can be, for example, a tyre assembly or machine drum.

⁹ Measurement reproducibility σ_m shall be estimated by measuring n times (where $n \geq 3$), on a single tyre, the whole procedure described in paragraph 4. of Annex 6 as follows:

$$\sigma_m = \sqrt{\frac{1}{n-1} \cdot \sum_{j=1}^n \left(Cr_j - \frac{1}{n} \cdot \sum_{j=1}^n Cr_j \right)^2}$$

Where:

j = is the counter from 1 to n for the number of repetitions of each measurement for a given tyre,

n = number of repetitions of tyre measurements ($n \geq 3$).

- 3.1.7. Tyre structure;
- 3.1.8. For Class C1 tyres, state whether:
- (a) Reinforced (or extra load) in case of approval with regard to rolling sound emission level;
 - (b) Speed category symbol "Q" or below (excluding "H") or "R" and above (including "H") in case of "snow" tyres for approval with regard to adhesion on wet surfaces;
- For Classes C2 and C3 tyres, state whether:
- (a) M+S marked in case of approval with regard to rolling sound emission level at stage 1;
 - (b) Traction in case of approval with regard to rolling sound emission level at stage 2.
- 3.1.9. Category of use (normal, snow, or special);
- 3.1.10. A list of tyre size designations covered by this application.
- 3.2. The application for approval shall be accompanied (in triplicate) by:
- 3.2.1. Details of the major features, with respect to the effects on the performance (i.e. rolling sound emission level, adhesion on wet surfaces, rolling resistance and snow grip) of the tyres, including the tread pattern, included in the designated range of tyre sizes. This may be by means of descriptions supplemented by technical data, drawings, photographs and Computer Tomography (CT), and must be sufficient to allow the Type Approval Authority or Technical Service to determine whether any subsequent changes to the major features will adversely affect the tyre performance. The effects of changes to minor details of tyre construction on tyre performances will be evident and determined during checks on conformity of production;
- 3.2.2. Drawings or photographs of the tyre sidewall, showing the information given in paragraph 3.1.8. above and the approval marking referred to in paragraph 4., shall be submitted once the production has been established, but no later than one year after the date of granting of type approval.
- 3.2.3. In the case of applications relating to special use tyres, a copy of the mould drawing of the tread pattern shall be supplied in order to allow verification of the void-to-fill ratio.
- 3.3. At the request of the Type Approval Authority, the applicant shall submit samples of tyres for test or copies of test reports from the Technical Services, communicated as given in paragraph 11. of this Regulation.
- 3.4. With regard to the application, testing may be confined to a worst case selection, at the discretion of the Type Approval Authority or designated Technical Service.
- 3.5. The laboratories and test facilities of a tyre manufacturer may be designated as an approved laboratory and the Type Approval Authority shall have the option of being represented during any tests.

4. Markings

- 4.1. All tyres constituting the type of tyre shall be marked as prescribed by either Regulation No. 30 or 54, as applicable.
- 4.2. In particular tyres shall bear:¹⁰
 - 4.2.1. The manufacturer's name or trade mark;
 - 4.2.2. The trade description (see paragraph 2.2. of this Regulation). However, the trade description is not required when it coincides with the trade mark;
 - 4.2.3. The tyre size designation;
 - 4.2.4. The inscription "REINFORCED" (or alternatively "EXTRA LOAD") if the tyre is classified as reinforced;
 - 4.2.5. The inscription "TRACTION"¹¹ if the tyre is classified as "traction tyre";
 - 4.2.6. The "Alpine" symbol ("3-peak-mountain with snowflake" conforming to the symbol described in Annex 7, Appendix 1) shall be added if the snow tyre is classified as "snow tyre for use in severe snow conditions".
 - 4.2.7. The inscription "MPT" (or alternatively "ML" or "ET") and /or "POR" if the tyre is classified in the category of use "special".

ET means Extra Tread, ML stands for Mining and Logging, MPT means Multi-Purpose Truck and POR means Professional Off-Road.
- 4.3. Tyres shall provide adequate space for the approval mark as shown in Annex 2 to this Regulation.
- 4.4. The approval mark shall be moulded into or onto the sidewall of the tyre, shall be clearly legible and shall be located in the lower area of the tyre on at least one of the sidewalls.
 - 4.4.1. However, in the case of tyres identified by the tyre to rim fitment configuration symbol "A", the marking may be located anywhere on the outside sidewall of the tyre.

5. Approval

- 5.1. If the representative tyre size of the type of tyre submitted for approval pursuant to this Regulation meets the requirements of paragraphs 6. and 7. below, approval of that type of tyre shall be granted.
- 5.2. An approval number shall be assigned to the type of tyre approved. The same Contracting Party may not assign the same number to another type of tyre.
- 5.3. Notice of approval or extension of approval or refusal of approval of a type of tyre pursuant to this Regulation shall be communicated to the Parties to the Agreement, which apply this Regulation by means of a form conforming to the model in Annex 1 to the Regulation.

¹⁰ Some of these requirements may be specified separately in Regulation No. 30 or 54.

¹¹ Minimum height of marking: refer to dimension C in Annex 3 of Regulation No. 54.

- 5.3.1. Tyre manufacturers are entitled to submit an application for extension of type approval to the requirements of other Regulations relevant to the tyre type. In that case, a copy of the relevant type approval communication(s), as issued by the relevant Type Approval Authority, shall be attached to the application for extension of approval. All applications for extension of approval(s) shall only be granted by the Type Approval Authority which issued the original approval for the tyre.
- 5.3.1.1. When extension of approval is granted to incorporate into the communication form (see Annex 1 to this Regulation) certification(s) of conformity to other Regulations, the approval number on the communication form shall be supplemented by suffix(es) to identify the given Regulation(s) and the technical prescriptions which have been incorporated by the extension of approval. In relation to each given suffix, the specific type approval number(s) and the Regulation itself shall be added to item 9. of Annex 1 - Communication form.
- 5.3.1.2. The prefix shall identify the series of amendments of the prescription on tyre performances for the relevant Regulation, e.g. 02S2 to identify the second series of amendments on tyre road rolling sound emissions at stage 2 or 02S1WR1 to identify the second series of amendments on tyre road rolling sound emissions at stage 1, tyre adhesion on wet surfaces and rolling resistance at stage 1 (see paragraph 6.1. below for stage 1 and stage 2 definitions). No identification to the series of amendments shall be required if the relevant Regulation is in its original form.
- 5.3.2. The following suffixes have been already reserved to identify specific Regulations on tyre performance parameters:
- S To identify additional conformity to the requirements on tyre rolling sound emissions;
 - W To identify additional conformity to the requirements on tyre adhesion on wet surfaces;
 - R To identify additional conformity to the requirements on tyre rolling resistance.
- Taking into account that two stages are defined for rolling sound and rolling resistance specifications in paragraphs 6.1. and 6.3. below, S and R will be followed either by the suffix "1" for compliance to stage 1 or by the suffix "2" for compliance to stage 2.
- 5.4. In the space referred to in paragraph 4.3. and in accordance with the requirements of paragraph 4.4. above there shall be affixed to every tyre size, conforming to the type of tyre approved under this Regulation, an international approval mark consisting of:
- 5.4.1. A circle surrounding the letter "E" followed by the distinguishing number of the country which has granted approval;¹² and

¹² The distinguishing numbers of the Contracting Parties to the 1958 Agreement are reproduced in Annex 3 to the Consolidated Resolution on the Construction of Vehicles (R.E.3), document ECE/TRANS/WP.29/78/Rev. 4, Annex 3 - www.unece.org/trans/main/wp29/wp29wgs/wp29gen/wp29resolutions.html

- 5.4.2. The approval number, which shall be placed close to the circle prescribed in paragraph 5.4.1. above either above or below the "E" or to the left or right of that letter.
- 5.4.3. The suffix(es), and the identification to the relevant series of amendments, if any, as specified in the communication form.

One of the suffixes listed below or any combination of them can be used.

| | |
|----|-------------------------------------|
| S1 | Sound level at stage 1 |
| S2 | Sound level at stage 2 |
| W | Wet adhesion level |
| R1 | Rolling resistance level at stage 1 |
| R2 | Rolling resistance level at stage 2 |

These suffixes shall be placed to the right or below the approval number, if part of the original approval.

If the approval is extended subsequent to Regulation No. 30 or 54 approvals, the addition sign "+" and the series of amendment to Regulation No. 117 shall be placed in front of the suffix or any combination of suffixes to denote an extension to the approval.

If the approval is extended subsequent to the original approval under Regulation No. 117, the addition sign "+" shall be placed between the suffix or any combination of suffixes of the original approval and the suffix or any combination of suffixes added to denote an extension to the approval.

- 5.4.4. The marking on the tyre sidewalls of suffix(es) to the approval number removes the requirement for any additional marking on the tyre of the specific type approval number for conformity to the Regulation(s) to which the suffix refers as per paragraph 5.3.2. above.
- 5.5. If the tyre conforms to type approvals under one or more other Regulations annexed to the Agreement in the country which has granted approval under this Regulation, the symbol prescribed in paragraph 5.4.1. above need not be repeated. In such a case the additional numbers and symbols of all the Regulations under which approval has been granted in the country which has granted approval under this Regulation shall be placed adjacent to the symbol prescribed in paragraph 5.4.1. above.
- 5.6. Annex 2 to this Regulation gives examples of arrangements of approval marks.

6. Specifications

- 6.1. Rolling sound emission limits, as measured by the method described in Annex 3 to this Regulation.
- 6.1.1. For Class C1 tyres, the rolling sound emission value shall not exceed the values pertinent to the applicable stage given below. These values refer to the nominal section width as given in paragraph 2.17.1.1. of Regulation No. 30:

| <i>Stage 1</i> | |
|------------------------------|--------------------|
| <i>Nominal section width</i> | <i>Limit dB(A)</i> |
| 145 and lower | 72 |
| Over 145 up to 165 | 73 |
| Over 165 up to 185 | 74 |
| Over 185 up to 215 | 75 |
| Over 215 | 76 |

The above limits shall be increased by 1 dB(A) for extra load tyres or reinforced tyres and by 2 dB(A) for "special use tyres".

| <i>Stage 2</i> | |
|------------------------------|--------------------|
| <i>Nominal section width</i> | <i>Limit dB(A)</i> |
| 185 and lower | 70 |
| Over 185 up to 245 | 71 |
| Over 245 up to 275 | 72 |
| Over 275 | 74 |

The above limits shall be increased by 1 dB(A) for "snow tyre for use in severe snow conditions", extra load tyres or reinforced tyres, or any combination of these classifications.

- 6.1.2. For Class C2 tyres, the rolling sound emission value with reference to its category of use (see paragraph 2.1., subparagraph (d) above) shall not exceed the values pertinent to the applicable stage given below:

| <i>Stage 1</i> | |
|------------------------|--------------------|
| <i>Category of use</i> | <i>Limit dB(A)</i> |
| Normal tyre | 75 |
| Snow tyre | 77 |
| Special use tyre | 78 |

| <i>Stage 2</i> | | | |
|------------------------|---|--------------------|-----------------------|
| <i>Category of use</i> | | <i>Limit dB(A)</i> | |
| | | <i>Other</i> | <i>Traction tyres</i> |
| Normal tyre | | 72 | 73 |
| Snow tyre | | 72 | 73 |
| | Snow tyre for use in severe snow conditions | 73 | 75 |
| Special use tyre | | 74 | 75 |

- 6.1.3. For Class C3 tyres, the rolling sound emission value with reference to its category of use (see paragraph 2.1., subparagraph (d) above) shall not exceed the values pertinent to the applicable stage given below:

| <i>Stage 1</i> | |
|------------------------|--------------------|
| <i>Category of use</i> | <i>Limit dB(A)</i> |
| Normal tyre | 76 |
| Snow tyre | 78 |
| Special use tyre | 79 |

| <i>Stage 2</i> | | | |
|------------------------|---|--------------------|-----------------------|
| <i>Category of use</i> | | <i>Limit dB(A)</i> | |
| | | <i>Other</i> | <i>Traction tyres</i> |
| Normal tyre | | 73 | 75 |
| Snow tyre | | 73 | 75 |
| | Snow tyre for use in severe snow conditions | 74 | 76 |
| Special use tyre | | 75 | 77 |

- 6.2. The wet grip performance will be based on a procedure that compares either peak brake force coefficient ("pbfc") or mean fully developed deceleration ("mffd") against values achieved by a standard reference test tyre (SRTT). The relative performance shall be indicated by a wet grip index (G).
- 6.2.1. For Class C1 tyres, tested in accordance with either procedure given in Annex 5, Part (A), to this Regulation, the tyre shall meet the following requirements:

| <i>Category of use</i> | | <i>Wet grip index (G)</i> |
|------------------------|---|---------------------------|
| Normal tyre | | ≥ 1.1 |
| Snow tyre | | ≥ 1.1 |
| | "Snow tyre for use in severe snow conditions" and with a speed symbol ("R" and above, including "H") indicating a maximum permissible speed greater than 160 km/h | ≥ 1.0 |
| | "Snow tyre for use in severe snow conditions" and with a speed symbol ("Q" or below excluding "H") indicating a maximum permissible speed not greater than 160 km/h | ≥ 0.9 |
| Special use tyre | | Not defined |

- 6.2.2. For Class C2 tyres, tested in accordance with either procedure given in Annex 5, Part (B), to this Regulation, the tyre shall meet the following requirements:

| Category of use | | Wet grip index (G) | |
|------------------|---|--------------------|----------------|
| | | Other | Traction tyres |
| Normal tyre | | ≥ 0.95 | ≥ 0.85 |
| Snow tyre | | ≥ 0.95 | ≥ 0.85 |
| | Snow tyre for use in severe snow conditions | ≥ 0.85 | ≥ 0.85 |
| Special use tyre | | ≥ 0.85 | ≥ 0.85 |

- 6.2.3. For Class C3 tyres, tested in accordance with either procedure given in Annex 5, Part (B), to this Regulation, the tyre shall meet the following requirements:

| Category of use | | Wet grip index (G) | |
|------------------|---|--------------------|----------------|
| | | Other | Traction tyres |
| Normal tyre | | ≥ 0.80 | ≥ 0.65 |
| Snow tyre | | ≥ 0.65 | ≥ 0.65 |
| | Snow tyre for use in severe snow conditions | ≥ 0.65 | ≥ 0.65 |
| Special use tyre | | ≥ 0.65 | ≥ 0.65 |

- 6.3. Rolling resistance coefficient limits, as measured by the method described in Annex 6 to this Regulation.

- 6.3.1. The maximum values for stage 1 for the rolling resistance coefficient shall not exceed the following (value in N/kN is equivalent to value in kg/tonne):

| Tyre class | Max value (N/kN) |
|------------|------------------|
| C1 | 12.0 |
| C2 | 10.5 |
| C3 | 8.0 |

For "snow tyre for use in severe snow conditions", the limits shall be increased by 1 N/kN.

- 6.3.2. The maximum values for stage 2 for the rolling resistance coefficient shall not exceed the following (value in N/kN is equivalent to value in kg/tonne):

| Tyre class | Max value (N/kN) |
|------------|------------------|
| C1 | 10.5 |
| C2 | 9.0 |
| C3 | 6.5 |

For "snow tyre for use in severe snow conditions", the limits shall be increased by 1 N/kN.

6.4. In order to be classified as a "snow tyre for use in severe snow conditions" the tyre shall meet the performance requirements of paragraph 6.4.1. below. The tyre shall meet these requirements based on a test method of Annex 7 by which:

- (a) The mean fully developed deceleration ("mfdd") in a braking test,
 - (b) Or alternatively an average traction force in a traction test,
 - (c) Or alternatively the average acceleration in an acceleration test
- of the candidate tyre is compared to that of a standard reference tyre.

The relative performance shall be indicated by a snow index.

6.4.1. Tyre snow performance requirements

6.4.1.1. Class C1, C2 and C3 tyres

The minimum snow index value, as calculated in the procedure described in Annex 7 and compared with the SRTT shall be as follows:

| Class of tyre | Snow grip index (brake on snow method) ^(a) | | Snow grip index (spin traction method) ^(b) | Snow grip index (acceleration method) ^(c) |
|---------------|---|----------------------|---|--|
| | Ref. = C1 – SRTT 14 | Ref. = C2 – SRTT 16C | Ref. = C1 – SRTT 14 | Ref. = C3N – SRTT 19.5 Ref. = C3W – SRTT 22.5 |
| C1 | 1.07 | No | 1.10 | No |
| C2 | No | 1.02 | 1.10 | No |
| C3 | No | No | No | 1.25 |

^(a) See paragraph 3. of Annex 7 to this Regulation

^(b) See paragraph 2. of Annex 7 to this Regulation

^(c) See paragraph 4. of Annex 7 to this Regulation

6.5. In order to be classified as a "traction tyre", a tyre is required to meet at least one of the conditions of paragraph 6.5.1. below.

6.5.1. The tyre shall have a tread pattern with minimum two circumferential ribs, each containing a minimum of 30 block-like elements, separated by grooves and/or sipe elements the depth of which has to be minimum of one half of the tread depth. The use of an alternative option of a physical test will only apply at a later stage following a further amendment to the Regulation including a reference to an appropriate test methods and limit values.

6.6. In order to be classified as a "special use tyre" a tyre shall have a block tread pattern in which the blocks are larger and more widely spaced than for normal tyres and have the following characteristics:

For C1 tyres: a tread depth \geq 11 mm and void to fill ratio \geq 35 per cent

For C2 tyres: a tread depth \geq 11 mm and void to fill ratio \geq 35 per cent

For C3 tyres: a tread depth \geq 16 mm and void to fill ratio \geq 35 per cent

- 6.7. In order to be classified as a "professional off-road tyre", a tyre shall have all of the following characteristics:
- (a) For C1 and C2 tyres:
 - (i) A tread depth ≥ 11 mm;
 - (ii) A void-to-fill ratio ≥ 35 per cent;
 - (iii) A maximum speed rating of $\leq Q$.
 - (b) For C3 tyres:
 - (i) A tread depth ≥ 16 mm;
 - (ii) A void-to-fill ratio ≥ 35 per cent;
 - (iii) A maximum speed rating of $\leq K$.

7. Modifications of the type of pneumatic tyre and extension of approval

- 7.1. Every modification of the type of tyre, which may influence the performance characteristics approved in accordance with this Regulation, shall be notified to the Type Approval Authority which approved the type of tyre. That Authority may either:
- 7.1.1. Consider that the modifications are unlikely to have any appreciable adverse effect on the performance characteristics approved and that the tyre will comply with the requirements of this Regulation; or
 - 7.1.2. Require further samples to be submitted for test or further test reports from the designated Technical Service.
 - 7.1.3. Confirmation or refusal of approval, specifying the modifications, shall be communicated by the procedure given in paragraph 5.3. of this Regulation to the Parties to the Agreement which apply this Regulation.
 - 7.1.4. The Type Approval Authority granting the extension of approval shall assign a series number for such an extension which shall be shown on the communication form.

8. Conformity of production

The conformity of production procedures shall comply with those set out in the Agreement, Appendix 2 (E/ECE/324-E/ECE/TRANS/505/Rev.2) with the following requirements:

- 8.1. Any tyre approved under this Regulation shall be so manufactured as to conform to the performance characteristics of the type of tyre approved and satisfy the requirements of paragraph 6. above;
- 8.2. In order to verify conformity as prescribed in paragraph 8.1. above, a random sample of tyres bearing the approval mark required by this Regulation shall be taken from the series production. The normal frequency of verification of conformity of production shall be at least once every two years;

- 8.2.1. In the case of verifications with regard to approvals in accordance with paragraph 6.2. of this Regulation, these shall be carried out using the same procedure (see Annex 5 to this Regulation) as that adopted for original approval, and the Type Approval Authority shall satisfy itself that all tyres falling within an approved type comply with the approval requirement. The assessment shall be based upon the production volume of the tyre type at each manufacturing facility, taking into account the quality management system(s) operated by the manufacturer. Where the test procedure involves testing a number of tyres at the same time, for example a set of four tyres for the purpose of testing wet grip performance in accordance with the standard vehicle procedure given in Annex 5 to this Regulation, then the set shall be considered as being one unit for the purposes of calculating the number of tyres to be tested.
- 8.3. Production shall be deemed to conform to the requirements of this Regulation if the levels measured comply with the limits prescribed in paragraph 6.1. of this Regulation, with an additional allowance of +1 dB(A) for possible mass production variations.
- 8.4. Production shall be deemed to conform to the requirements of this Regulation if the levels measured comply with the limits prescribed in paragraph 6.3. of this Regulation, with an additional allowance of +0.3 N/kN for possible mass production variations.

9. Penalties for non-conformity of production

- 9.1. The approval granted in respect of a type of tyre pursuant to this Regulation may be withdrawn if the requirements laid down in paragraph 8. above are not complied with, or if any tyre of the type of tyre exceeds the limits given in paragraph 8.3. or 8.4. above.
- 9.2. If a Party to the Agreement, which applies this Regulation, withdraws an approval, it has previously granted, it shall forthwith notify the other Contracting Parties applying this Regulation by means of a copy of the approval form conforming to the model in Annex 1 to this Regulation.

10. Production definitively discontinued

If the holder of an approval completely ceases to manufacture a type of pneumatic tyre approved in accordance with this Regulation, he shall so inform the Type Approval Authority, which granted the approval. Upon receiving the relevant communication that Authority shall inform thereof the other Parties to the 1958 Agreement applying this Regulation by means of a communication form conforming to the model in Annex 1 to this Regulation.

11. Names and addresses of Technical Services responsible for conducting approval tests of Type Approval Authorities

The Parties to the Agreement which apply this Regulation shall communicate to the United Nations Secretariat, the names and addresses of the Technical Services conducting approval tests and of the Type Approval Authority which grant approval and to which forms certifying approval or extension of approval or refusal or withdrawal of approval, issued in other countries, are to be sent.

12. Transitional provisions

- 12.1. As from the date of entry into force of the 02 series of amendments to this Regulation, Contracting Parties applying this Regulation shall not refuse to grant approval under this Regulation for a type of tyre if the tyre complies with the requirements of the 02 series of amendments, including the stage 1 or stage 2 rolling sound requirements set out in paragraphs 6.1.1. to 6.1.3. of this Regulation, the requirements for wet grip performance set out in paragraph 6.2.1. of this Regulation, and the stage 1 or stage 2 rolling resistance requirements set out in paragraph 6.3.1. or 6.3.2. of this Regulation.
- 12.2. As from 1 November 2012, Contracting Parties applying this Regulation shall refuse to grant approval if the tyre type to be approved does not meet the requirements of this Regulation as amended by the 02 series of amendments, and shall, in addition, refuse to grant approval if the stage 2 rolling sound requirements set out in paragraphs 6.1.1. to 6.1.3. of this Regulation, the requirements for wet grip performance set out in paragraph 6.2.1. of this Regulation, and the stage 1 rolling resistance requirements set out in paragraph 6.3.1. of this Regulation are not complied with.
- 12.3. As from 1 November 2014, Contracting Parties applying this Regulation may refuse to allow the sale or entry into service of a tyre which does not meet the requirements of this Regulation as amended by the 02 series, and which does not meet the requirements of this Regulation as amended by the 02 series of amendments including the wet grip performance requirements set out in paragraph 6.2.1. of this Regulation.
- 12.4. As from 1 November 2016, Contracting Parties applying this Regulation shall refuse to grant approvals if the tyre type to be approved does not meet the requirements of this Regulation as amended by the 02 series of amendments including the stage 2 rolling resistance requirements set out in paragraph 6.3.2. of this Regulation and the wet grip requirements set out in paragraphs 6.2.2. and 6.2.3. of this Regulation.
- 12.5. As from 1 November 2016, any Contracting Party applying this Regulation may refuse to allow the sale or entry into service of a tyre which does not meet the requirements of this Regulation as amended by the 02 series, and which does not meet the stage 2 rolling sound requirements set out in paragraphs 6.1.1. to 6.1.3. of this Regulation.

- 12.6. As from the dates given below, any Contracting Party applying this Regulation may refuse to allow the sale or entry into service of a tyre which does not meet the requirements of this Regulation as amended by the 02 series, and which does not meet the stage 1 rolling resistance requirements set out in paragraph 6.3.1. of this Regulation:

| <i>Tyre class</i> | <i>Date</i> |
|-------------------|-----------------|
| C1, C2 | 1 November 2014 |
| C3 | 1 November 2016 |

- 12.7. As from the dates given below, any Contracting Party applying this Regulation may refuse to allow the sale or entry into service of a tyre which does not meet the requirements of this Regulation as amended by the 02 series, and which does not meet the stage 2 rolling resistance requirements set out in paragraph 6.3.2. of this Regulation and the wet grip requirements set out in paragraphs 6.2.2. and 6.2.3. of this Regulation:

| <i>Tyre class</i> | <i>Date</i> |
|-------------------|-----------------|
| C1 and C2 | 1 November 2018 |
| C3 | 1 November 2020 |

- 12.8. Until 13 February 2019 (60 months after the entry into force of Supplement 4 to the 02 series of amendments to this Regulation) Contracting Parties applying this Regulation may continue to grant type approvals according to the 02 series of amendments to this Regulation, based on the provisions of Annex 4 to this Regulation.

Annex 1

Communication

(Maximum format: A4 (210 x 297 mm))



Issued by: Name of administration:

.....

Concerning:² Approval granted
 Approval extended
 Approval refused
 Approval withdrawn
 Production definitively discontinued

of a type of tyre with regard to "rolling sound emission level" and/or "adhesion performance on wet surfaces" and/or "rolling resistance" pursuant to Regulation No. 117

Approval No. Extension No.

1. Manufacturer's name and address(es):
2. If applicable, name and address of manufacturer's representative:
3. "Tyre class" and "category of use" of the type of tyre:
- 3.1. Snow tyre for use in severe snow conditions (Yes/No)²
- 3.2. Traction tyre (Yes/No)²
4. Brand(s) name(s) and/or Trade description(s) of the type of tyre:
5. Technical Service and, where appropriate, test laboratory approved for purposes of approval or of verification of conformity tests:
6. Performance(s) approved: sound level at (stage 1/stage 2),² wet adhesion level, rolling resistance level (stage 1/stage 2)²
 - 6.1. Sound level of the representative tyre size, see paragraph 2.5. of this Regulation, as per item 7. of the test report in Appendix 1 to Annex 3: dB(A) at reference speed of 70/80 km/h²
 - 6.2. Wet adhesion level of the representative tyre size, see paragraph 2.5. of this Regulation, as per item 7. of the test report in the appendix to Annex 5: (G) using the vehicle or trailer method²

¹ Distinguishing number of the country which has granted/extended/refused/withdrawn approval (see approval provisions in the Regulation).

² Strike out what does not apply.

- 6.3. Rolling resistance level of the representative tyre size, see paragraph 2.5. of this Regulation, as per item 7. of the test report in Appendix 1 to Annex 6
- 6.4. Snow grip level of the representative tyre size, see paragraph 2.5. of Regulation No. 117, as per item 7. of the test report in the appendix³ to Annex 7:.....
(Snow grip index) using the brake on snow method², spin traction method² or acceleration method.²
7. Number of report issued by the Technical Service:
8. Date of report issued by that Service:
9. Reason(s) of extension (if applicable):
10. Any remarks:.....
11. Place:
12. Date:
13. Signature:
14. Annexed to this communication are:
- 14.1. A list of documents in the approval file deposited at the Type Approval Authorities having delivered the approval and which can be obtained upon request. ⁴
- 14.2. A list of tread-pattern designations: Specify for each trademark or brand name and trade description the list of tyre size designations, adding in case of Class C1 tyres the mark "reinforced" (or "extra load") or the speed symbol of snow tyres or in the case of tyres of Classes C2 and C3, the mark "traction", if so required by paragraph 3.1. of this Regulation.

³ Appendix 2 for C1 and C2 tyres.
Appendix 3 for C3 tyres.

⁴ In the case of "snow tyre for use in severe snow conditions" a test report according to Appendix 2 to Annex 7 shall be submitted.

Annex 2 - Appendix 1

Example of approval marks

Arrangements of approval marks

(See paragraph 5.4. of this Regulation)

Approval according to Regulation No. 117

Example 1

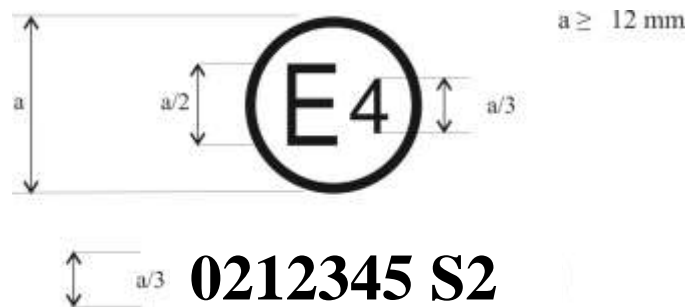

The above approval mark, affixed to a pneumatic tyre shows that a tyre concerned has been approved in the Netherlands (E 4) pursuant to Regulation No. 117 (marked by S2 (rolling sound at stage 2) only), under approval number 0212345. The first two digits of the approval number (02) indicate that the approval was granted according to the requirements 02 series of amendments to this Regulation.

Example 2

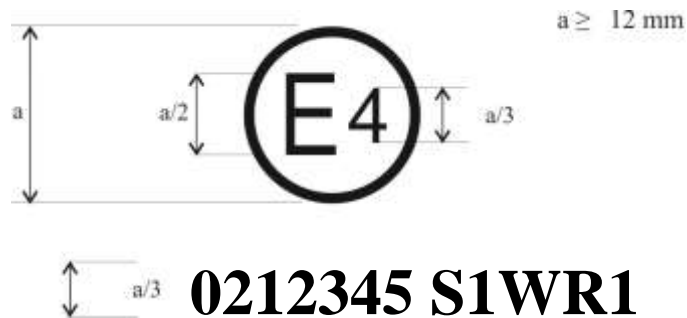

The above approval mark shows that the tyre concerned has been approved in the Netherlands (E 4) pursuant to Regulation No. 117 (marked by S1 (rolling sound at stage 1) W (wet adhesion), and R1 (Rolling resistance at stage 1) under approval number 0212345. This indicates that the approval is for S1WR1. The first two digits of the approval number (02) indicate that the approval was granted according to the requirements of the 02 series of amendments to this Regulation.

Annex 2 - Appendix 2

Approval according to Regulation No. 117 coincident with approval of Regulation No. 30 or 54¹

Example 1

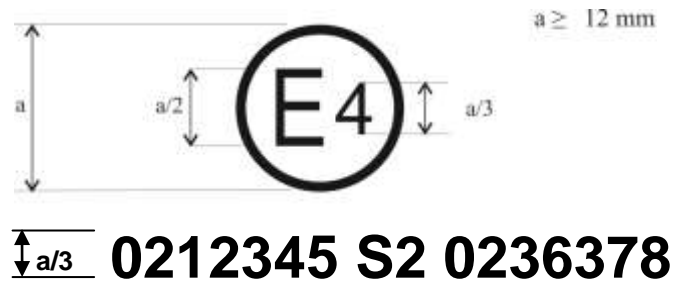

The above approval mark shows that the tyre concerned has been approved in the Netherlands (E 4) pursuant to Regulation No. 117 (marked by S2 (rolling sound at stage 2)), under approval number 0212345 and Regulation No. 30, under approval number 0236378. The first two digits of the approval number (02) indicate that the approval was granted according to the 02 series of amendments and Regulation No. 30 included the 02 series of amendments.

¹ Approvals in accordance with Regulation No. 117 for tyres within the scope of Regulation No. 54 currently do not include wet adhesion requirements.

Example 2



$\frac{a}{3}$ **0212345 S2 0236378**



or



0212345 S2WR2



0236378

The above approval mark shows that the tyre concerned has been approved in the Netherlands (E 4) pursuant to Regulation No. 117 (marked by S2WR2 (rolling sound at stage 2 wet adhesion and rolling resistance at stage 2)), under approval number 0212345 and Regulation No. 30 under approval number 0236378. The first two digits of the approval number (02) indicate that the approval was granted according to the 02 series of amendments and Regulation No. 30 included the 02 series of amendments.

Example 3



$\frac{a}{3}$ **0212345 S2 0054321**

The above approval mark shows that the tyre concerned has been approved in the Netherlands (E 4) pursuant to Regulation No. 117 and the 02 series of amendments under approval number 0212345 (marked by S2), and Regulation No. 54. This indicates that the approval is for rolling sound stage 2 (S2). The first two digits of the Regulation No. 117 approval number (02) in conjunction with "S2" indicate that the first approval was granted in accordance with Regulation No. 117 which included the 02 series of amendments. The first two digits of Regulation No. 54 (00) indicate that this Regulation was in its original form.

Example 4



$a/3$ 0212345 S2 0054321

The above approval mark shows that the tyre concerned has been approved in the Netherlands (E 4) pursuant to Regulation No. 117 and the 02 series of amendments under approval number 0212345 (marked by S2 R2), and Regulation No. 54. This indicates that the approval is for rolling sound stage 2 (S2) and rolling resistance stage 2. The first two digits of the Regulation No. 117 approval number (02) in conjunction with "S2R2" indicate that the first approval was granted in accordance with Regulation No. 117 which included the 02 series of amendments. The first two digits of Regulation No. 54 (00) indicate that this Regulation was in its original form.

Annex 2 - Appendix 3

Extensions to combine approvals issued in accordance with Regulations Nos. 117, 30 or 54¹

Example 1

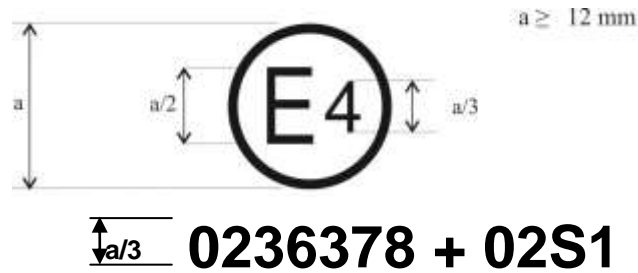

The above approval mark shows that the tyre concerned has been initially approved in the Netherlands (E 4) pursuant to Regulation No. 30 and the 02 series of amendments under approval number 0236378. It is also marked by + 02S1 (rolling sound at stage 1) which indicates that its approval is extended under Regulation No. 117 (02 series of amendments). The first two digits of the approval number (02) indicate that the approval was granted according to Regulation No. 30 (02 series of amendments). The addition (+) sign indicates that the first approval was granted in accordance with Regulation No. 30 and has been extended to include the approval(s) granted according to Regulation No. 117 (02 series of amendments) for rolling sound at stage 1.

Example 2

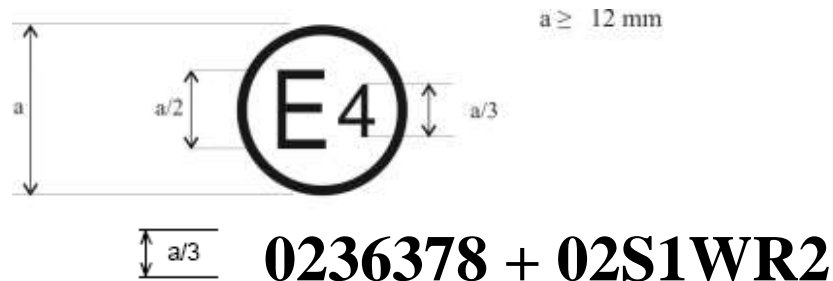

The above approval mark shows that the tyre concerned has been initially approved in the Netherlands (E 4) pursuant to Regulation No. 30 and the 02 series of amendments under approval number 0236378. This indicates that the approval is for S1 (rolling sound at stage 1) W (wet adhesion) and R2 (rolling resistance at stage 2). The S1WR2 preceded by (02) indicates that it has had its approval extended under Regulation No. 117 which included the 02 series of amendments. The first two digits of the approval number (02) indicate that the approval was granted according to Regulation No. 30 (02 series of amendments). The addition (+) sign indicates that the first approval was granted in accordance with Regulation No. 30 and has been extended to include Regulation No. 117 approval(s) (02 series of amendments).

¹ Approvals in accordance with Regulation No. 117 for tyres within the scope of Regulation No. 54 currently do not include wet adhesion requirements.

Annex 2 - Appendix 4

Extensions to combine approvals issued in accordance with Regulation No. 117¹

Example 1



$\overline{a/3}$ **0212345 W + S2R2**

The above approval mark shows that the tyre concerned has been initially approved in the Netherlands (E 4) pursuant to Regulation No. 117 and the 02 series of amendments under approval number 0212345. This indicates that the approval is for W (wet grip). The S2R2 preceded by + indicates that it has had its approval extended under Regulation No. 117 to rolling sound at stage 2 and rolling resistance at stage 2 based on separate certificate(s).

Example 2

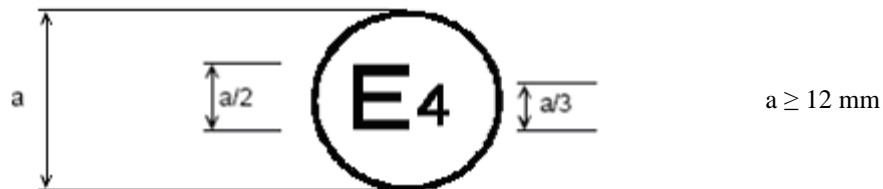

$\overline{a/3}$ **0212345 S1W + R1**

The above approval mark shows that the tyre concerned has been initially approved in the Netherlands (E 4) pursuant to Regulation No. 117 and the 02 series of amendments under approval number 0212345. This indicates that the approval is for S1 (rolling sound at stage 1) and W (wet grip). The R1 preceded by + indicates that it has had its approval extended under Regulation No. 117 to rolling resistance at stage 1 based on separate certificate(s).

¹ Approvals in accordance with Regulation No. 117 for tyres within the scope of Regulation No. 54 currently do not include wet adhesion requirements.



$\overline{a/3}$ **0167890 SW + 02R1**

The above approval mark shows that the tyre concerned has been initially approved in the Netherlands (E 4) pursuant to Regulation No. 117 and the 01 series of amendments under approval number 0167890. This indicates that the approval is for S (rolling sound at stage 1) and W (wet grip). The 02R1 preceded by + indicates that it has had its approval extended under Regulation No. 117 and the 02 series of amendments to rolling resistance at stage 1 based on separate certificate(s).

Annex 3

Coast-by test method for measuring tyre-rolling sound emission

Introduction

The presented method contains specifications on measuring instruments, measurement conditions and the measurement method, in order to obtain the sound level of a set of tyres mounted on a test vehicle rolling on a specified road surface. The maximum sound pressure level is to be recorded, when the test vehicle is coasting, by remote-field microphones; the final result for a reference speed is obtained from a linear regression analysis. Such test results cannot be related to tyre rolling sound measured during acceleration under power or deceleration under braking.

1. Measuring instruments

1.1. Acoustic measurements

The sound level meter or the equivalent measuring system, including the windscreen recommended by the manufacturer shall meet or exceed the requirements of Type 1 instruments in accordance with IEC 60651:1979/A1:1993, second edition.

The measurements shall be made using the frequency weighting A, and the time weighting F.

When using a system that includes a periodic monitoring of the A-weighted sound level, a reading should be made at a time interval not greater than 30 ms.

1.1.1. Calibration

At the beginning and at the end of every measurement session, the entire measurement system shall be checked by means of a sound calibrator that fulfils the requirements for sound calibrators of at least precision Class 1 according to IEC 60942:1988. Without any further adjustment the difference between the readings of two consecutive checks shall be less than or equal to 0.5 dB(A). If this value is exceeded, the results of the measurements obtained after the previous satisfactory check shall be discarded.

1.1.2. Compliance with requirements

The compliance of the sound calibration device with the requirements of IEC 60942:1988 shall be verified once a year and the compliance of the instrumentation system with the requirements of IEC 60651:1979/A1:1993, second edition shall be verified at least every two years, by a laboratory which is authorized to perform calibrations traceable to the appropriate standards.

- 1.1.3. Positioning of the microphone
- The microphone (or microphones) shall be located at a distance of 7.5 ± 0.05 m from track reference line CC' (Figure 1) and 1.2 ± 0.02 m above the ground. Its axis of maximum sensitivity shall be horizontal and perpendicular to the path of the vehicle (line CC').
- 1.2. Speed measurements
- The vehicle speed shall be measured with instruments with accuracy of ± 1 km/h or better when the front end of the vehicle has reached line PP (Figure 1).
- 1.3. Temperature measurements
- Measurements of air as well as test surface temperature are mandatory.
- The temperature measuring devices shall be accurate within ± 1 °C.
- 1.3.1. Air temperature
- The temperature sensor is to be positioned in an unobstructed location close to the microphone in such a way that it is exposed to the airflow and protected from direct solar radiation. The latter may be achieved by any shading screen or similar device. The sensor should be positioned at a height of 1.2 ± 0.1 m above the test surface level, to minimize the influence of the test surface thermal radiation at low airflows.
- 1.3.2. Test surface temperature
- The temperature sensor is to be positioned in a location where the temperature measured is representative of the temperature in the wheel tracks, without interfering with the sound measurement.
- If an instrument with a contact temperature sensor is used, heat-conductive paste shall be applied between the surface and the sensor to ensure adequate thermal contact.
- If a radiation thermometer (pyrometer) is used, the height should be chosen to ensure that a measuring spot with a diameter of ≥ 0.1 m is covered.
- 1.4. Wind measurement
- The device shall be capable of measuring the wind speed with a tolerance of ± 1 m/s. The wind shall be measured at microphone height. The wind direction with reference to the driving direction shall be recorded.
2. Conditions of measurement
- 2.1. Test site
- The test site shall consist of a central section surrounded by a substantially flat test area. The measuring section shall be level; the test surface shall be dry and clean for all measurements. The test surface shall not be artificially cooled during or prior the testing.
- The test track shall be such that the conditions of a free sound field between the sound source and the microphone are attained to within 1 dB(A). These conditions shall be deemed to be met if there is no large sound reflecting objects, such as fences, rocks, bridges or building within 50 m of the centre of the measuring section. The surface of the test track and the dimensions of

the test site shall be in accordance with ISO 10844:2014. Until the end of the period indicated in paragraph 12.8. of this Regulation the specifications for the test site may be in accordance with Annex 4 to this Regulation.

A central part of at least 10 m radius shall be free of powdery snow, tall grass, loose soil, cinders or the like. There shall be no obstacle, which could affect the sound field within the vicinity of the microphone and no persons shall stand between the microphone and the sound source. The operator carrying out the measurements and any observers attending the measurements shall position themselves so as not to affect the readings of the measuring instruments.

2.2. Meteorological conditions

Measurements shall not be made under poor atmospheric conditions. It shall be ensured that the results are not affected by gusts of wind. Testing shall not be performed if the wind speed at the microphone height exceeds 5 m/s.

Measurements shall not be made if the air temperature is below 5 °C or above 40 °C or the test surface temperature is below 5 °C or above 50 °C.

2.3. Ambient noise

2.3.1. The background sound level (including any wind noise) shall be at least 10 dB(A) less than the measured tyre rolling sound emission. A suitable windscreen may be fitted to the microphone provided that account is taken of its effect on the sensitivity and directional characteristics of the microphone.

2.3.2. Any measurement affected by a sound peak which appears to be unrelated to the characteristics of the general sound level of tyres, shall be ignored.

2.4. Test vehicle requirements

2.4.1. General

The test vehicle shall be a motor vehicle and be fitted with four single tyres on just two axles.

2.4.2. Vehicle load

The vehicle shall be loaded such as to comply with the test tyre loads as specified in paragraph 2.5.2. below.

2.4.3. Wheelbase

The wheelbase between the two axles fitted with the test tyres shall for Class C1 be less than 3.50 m and for Class C2 and Class C3 tyres be less than 5 m.

2.4.4. Measures to minimize vehicle influence on sound level measurements

To ensure that tyre rolling sound is not significantly affected by the test vehicle design the following requirements and recommendations are given.

2.4.4.1. Requirements:

- (a) Spray suppression flaps or other extra device to suppress spray shall not be fitted;
- (b) Addition or retention of elements in the immediate vicinity of the rims and tyres, which may screen the emitted sound, is not permitted;
- (c) Wheel alignment (toe in, camber and caster) shall be in full accordance with the vehicle manufacturer's recommendations;

- (d) Additional sound absorbing material may not be mounted in the wheel housings or under the underbody;
- (e) Suspension shall be in such a condition that it does not result in an abnormal reduction in ground clearance when the vehicle is loaded in accordance with the testing requirement. If available, body level Regulation systems shall be adjusted to give a ground clearance during testing which is normal for unladen condition.

2.4.4.2. Recommendations to avoid parasitic noise:

- (a) Removal or modification on the vehicle that may contribute to the background noise of the vehicle is recommended. Any removals or modifications shall be recorded in the test report;
- (b) During testing it should be ascertained that brakes are not poorly released, causing brake noise;
- (c) It should be ascertained that electric cooling fans are not operating;
- (d) Windows and sliding roof of the vehicle shall be closed during testing.

2.5. Tyres

2.5.1. General

Four identical tyres shall be fitted on the test vehicle. In the case of tyres with a load capacity index in excess of 121 and without any dual fitting indication, two of these tyres of the same type and range shall be fitted to the rear axle of the test vehicle; the front axle shall be fitted with tyres of size suitable for the axle load and planed down to the minimum depth in order to minimize the influence of tyre/road contact noise while maintaining a sufficient level of safety. Winter tyres that in certain Contracting Parties may be equipped with studs intended to enhance friction shall be tested without this equipment. Tyres with special fitting requirements shall be tested in accordance with these requirements (e.g. rotation direction). The tyres shall have full tread depth before being run-in.

Tyres are to be tested on rims permitted by the tyre manufacturer.

2.5.2. Tyre loads

The test load Q_t for each tyre on the test vehicle shall be 50 to 90 per cent of the reference load Q_r , but the average test load $Q_{t,avr}$ of all tyres shall be 75 ± 5 per cent of the reference load Q_r .

For all tyres the reference load Q_r corresponds to the maximum mass associated with the load capacity index of the tyre. In the case where the load capacity index is constituted by two numbers divided by slash (/), reference shall be made to the first number.

2.5.3. Tyre inflation pressure

Each tyre fitted on the test vehicle shall have a test pressure P_t not higher than the reference pressure P_r and within the interval:

$$P_r \times \left(\frac{Q_t}{Q_r} \right)^{1.25} \leq P_t \leq 1.1 P_r \times \left(\frac{Q_t}{Q_r} \right)^{1.25}$$

For Class C2 and Class C3 the reference pressure P_r is the pressure corresponding to the pressure index marked on the sidewall.

For Class C1 the reference pressure is $P_r = 250$ kPa for "standard" tyres and 290 kPa for "reinforced" or "extra load" tyres; the minimum test pressure shall be $P_t = 150$ kPa.

2.5.4. Preparations prior to testing

The tyres shall be "run-in" prior to testing to remove compound nodules or other tyre pattern characteristics resulting from the moulding process. This will normally require the equivalent of about 100 km of normal use on the road.

The tyres fitted to the test vehicle shall rotate in the same direction as when they were run-in.

Prior to testing tyres shall be warmed up by running under test conditions.

3. Method of testing

3.1. General conditions

For all measurements the vehicle shall be driven in a straight line over the measuring section (AA' to BB') in such a way that the median longitudinal plane of the vehicle is as close as possible to the line CC'.

When the front end of the test vehicle has reached the line AA' the vehicle driver shall have put the gear selector on neutral position and switched off the engine. If abnormal noise (e.g. ventilator, self-ignition) is emitted by the test vehicle during the measurement, the test shall be disregarded.

3.2. Nature and number of measurements

The maximum sound level expressed in A-weighted decibels (dB(A)) shall be measured to the first decimal place as the vehicle is coasting between lines AA' and BB' (Figure 1 - front end of the vehicle on line AA', rear end of the vehicle on line BB'). This value will constitute the result of the measurement.

At least four measurements shall be made on each side of the test vehicle at test speeds lower than the reference speed specified in paragraph 4.1. below and at least four measurements at test speeds higher than the reference speed. The speeds shall be approximately equally spaced over the speed range specified in paragraph 3.3. below.

3.3. Test speed range

The test vehicle speeds shall be within the range:

- (a) From 70 to 90 km/h for Class C1 and Class C2 tyres;
- (b) From 60 to 80 km/h for Class C3 tyres.

4. Interpretation of results

The measurement shall be invalid if an abnormal discrepancy between the values is recorded (see paragraph 2.3.2. of this annex).

4.1. Determination of test result

Reference speed V_{ref} used to determine the final result will be:

- (a) 80 km/h for Class C1 and Class C2 tyres;
- (b) 70 km/h for Class C3 tyres.

4.2. Regression analysis of rolling sound measurements

The tyre-road rolling sound level L_R in dB(A) is determined by a regression analysis according to:

$$L_R = \bar{L} - a \cdot \bar{v}$$

Where:

\bar{L} is the mean value of the rolling sound levels L_i , measured in dB(A):

$$\bar{L} = \frac{1}{n} \sum_{i=1}^n L_i$$

n is the measurement number ($n \geq 16$),

\bar{v} is the mean value of logarithms of speeds V_i :

$$\bar{v} = \frac{1}{n} \sum_{i=1}^n v_i \quad \text{with} \quad v_i = \lg\left(\frac{V_i}{V_{ref}}\right)$$

a is the slope of the regression line in dB(A):

$$a = \frac{\sum_{i=1}^n (v_i - \bar{v})(L_i - \bar{L})}{\sum_{i=1}^n (v_i - \bar{v})^2}$$

4.3. Temperature correction

For Class C1 and Class C2 tyres, the final result shall be normalized to a test surface reference temperature ϑ_{ref} by applying a temperature correction, according to the following:

$$L_R(\vartheta_{ref}) = L_R(\vartheta) + K(\vartheta_{ref} - \vartheta)$$

Where:

ϑ = the measured test surface temperature,

ϑ_{ref} = 20 °C,

For Class C1 tyres, the coefficient K is: -0.03 dB(A)/°C, when $\vartheta > \vartheta_{ref}$

and -0.06 dB(A)/°C when $\vartheta < \vartheta_{ref}$.

For Class C2 tyres, the coefficient K is -0.02 dB(A)/°C

If the measured test surface temperature does not change more than 5 °C within all measurements necessary for the determination of the sound level of one set of tyres, the temperature correction may be made only on the final reported tyre rolling sound level as indicated above, utilizing the arithmetic mean value of the measured temperatures. Otherwise each measured sound level L_i shall be corrected, utilizing the temperature at the time of the sound recording.

There will be no temperature correction for Class C3 tyres.

- 4.4. In order to take account of any measuring instrument inaccuracies, the results according to paragraph 4.3. above shall be reduced by 1 dB(A).
- 4.5. The final result, the temperature corrected tyre rolling sound level $L_R(9_{ref})$ in dB(A), shall be rounded down to the nearest lower whole value.

Figure 1
Microphone positions for the measurement

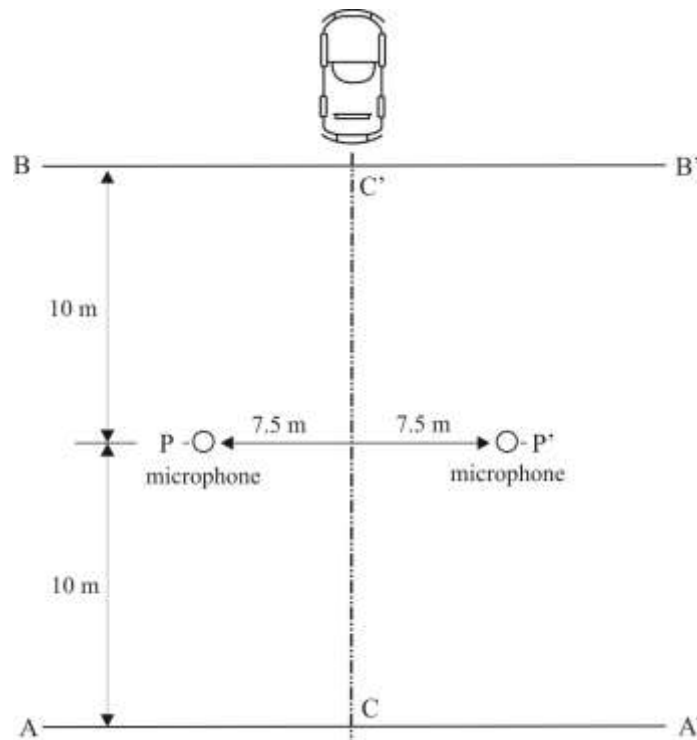

Annex 3 - Appendix 1

Test report

Part 1 - Report

1. Type Approval Authority or Technical Service:
2. Name and address of applicant:
.....
3. Test report No.:
4. Manufacturer and Brand Name or Trade description:
5. Tyre Class (C1, C2 or C3):
6. Category of use:
7. Sound level according to paragraphs 4.4. and 4.5. of Annex 3: dB(A)
at reference speed of 70/80 km/h¹
8. Comments (if any):
.....
9. Date:
10. Signature:

Part 2 - Test data

1. Date of test:
2. Test vehicle (Make, model, year, modifications, etc.):
.....
- 2.1. Test vehicle wheelbase: mm
3. Location of test track:
- 3.1. Date of track certification to ISO 10844:2014:
- 3.2. Issued by:
- 3.3. Method of certification:
4. Tyre test details:
- 4.1. Tyre size designation:
- 4.2. Tyre service description:
- 4.3. Reference inflation pressure: kPa

¹ Strike out what does not apply.

4.4. Test data:

| | <i>Front left</i> | <i>Front right</i> | <i>Rear left</i> | <i>Rear right</i> |
|---------------------------------|-------------------|--------------------|------------------|-------------------|
| Test mass (kg) | | | | |
| Tyre load index (%) | | | | |
| Inflation pressure (cold) (kPa) | | | | |

4.5. Test rim width code:

4.6. Temperature measurement sensor type:

5. Valid test results:

| <i>Run No.</i> | <i>Test speed km/h</i> | <i>Direction of run</i> | <i>Sound level left¹ measured dB(A)</i> | <i>Sound level right¹ measured dB(A)</i> | <i>Air temp. °C</i> | <i>Track temp. °C</i> | <i>Sound level left¹ temp. corrected dB(A)</i> | <i>Sound level right¹ temp. corrected dB(A)</i> | <i>Comments</i> |
|----------------|------------------------|-------------------------|--|---|---------------------|-----------------------|---|--|-----------------|
| 1 | | | | | | | | | |
| 2 | | | | | | | | | |
| 3 | | | | | | | | | |
| 4 | | | | | | | | | |
| 5 | | | | | | | | | |
| 6 | | | | | | | | | |
| 7 | | | | | | | | | |
| 8 | | | | | | | | | |

¹ Relative to the vehicle.

5.1. Regression line slope:

5.2. Sound level after temperature correction according to paragraph 4.3. of Annex 3:
 dB(A)

Annex 4

Specifications for the test site¹

1. Introduction

This annex describes the specifications relating to the physical characteristics and the laying of the test track. These specifications based on a special standard² describe the required physical characteristics as well as the test methods for these characteristics.

2. Required characteristics of the surface

A surface is considered to conform to this standard provided that the texture and voids content or sound absorption coefficient have been measured and found to fulfil all the requirements of paragraphs 2.1. to 2.4. below and provided that the design requirements (paragraph 3.2. below) have been met.

2.1. Residual voids content

The residual Voids Content (VC) of the test track paving mixture shall not exceed 8 per cent. For the measurement procedure, see paragraph 4.1. of this annex.

2.2. Sound absorption coefficient

If the surface fails to comply with the residual voids content requirement, the surface is acceptable only if its sound absorption coefficient is $\alpha \leq 0.10$. For the measurement procedure, see paragraph 4.2. below. The requirements of this paragraph 2.1. above are met also if only sound absorption has been measured and found to be $\alpha \leq 0.10$.

Note: The most relevant characteristic is the sound absorption, although the residual voids content is more familiar among road constructors. However, sound absorption needs to be measured only if the surface fails to comply with the voids requirement. This is motivated because the latter is connected with relatively large uncertainties in terms of both measurements and relevance and some surfaces therefore erroneously may be rejected when based only on the voids measurement.

2.3. Texture depth

The Texture Depth (TD) measured according to the volumetric method (see paragraph 4.3. below) shall be:

$$TD \geq 0.4 \text{ mm}$$

¹ The specifications for the test site reproduced in this annex are valid until the end of the period indicated in paragraph 12.8. of this Regulation.

² ISO 10844:2014.

2.4. Homogeneity of the surface

Every practical effort shall be taken to ensure that the surface is made to be as homogeneous as possible within the test area. This includes the texture and voids content, but it should also be observed that if the rolling process results in more effective rolling at some places than others, the texture may be different and unevenness causing bumps may also occur.

2.5. Period of testing

In order to check whether the surface continues to conform to the texture and voids content or sound absorption requirements stipulated in this standard, periodic testing of the surface shall be done at the following intervals:

(a) For residual VC or sound absorption (α):

When the surface is new:

If the surface meets the requirements when new, no further periodical testing is required. If it does not meet the requirement when it is new, it may do so later because surfaces tend to become clogged and compacted with time;

(b) For TD:

When the surface is new:

When the noise testing starts (*Note*: Not before four weeks after laying);

Then every twelve months.

3. Test surface design

3.1. Area

When designing the test track layout it is important to ensure that, as a minimum requirement, the area traversed by the vehicles running through the test strip is covered with the specified test material with suitable margins for safe and practical driving. This will require that the width of the track is at least 3 m and the length of the track extends beyond lines AA and BB by at least 10 m at either end. Figure 1 shows a plan of a suitable test site and indicates the minimum area which shall be machine laid and machine compacted with the specified test surface material. According to Annex 3, paragraph 3.2., measurements have to be made on each side of the vehicle. This can be made either by measuring with two microphone locations (one on each side of the track) and driving in one direction, or measuring with a microphone only on one side of the track but driving the vehicle in two directions. If the latter method is used, then there are no surface requirements on that side of the track where there is no microphone.

Figure 1
Minimum requirements for test surface area. The shaded part is called "Test area"

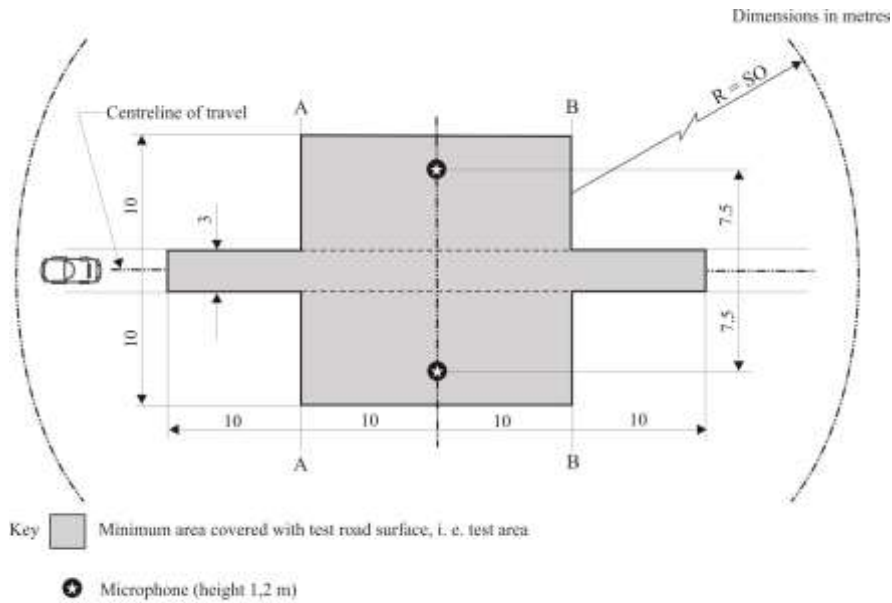

NOTE - There shall be no large acoustically reflective objects within this radius.

3.2. Design and preparation of the surface

3.2.1. Basic design requirements

The test surface shall meet four design requirements:

- 3.2.1.1. It shall be a dense asphaltic concrete.
- 3.2.1.2. The maximum chipping size shall be 8 mm (tolerances allow from 6.3 mm to 10 mm).
- 3.2.1.3. The thickness of the wearing course shall be ≥ 30 mm.
- 3.2.1.4. The binder shall be a straight penetration grade bitumen without modification.

3.2.2. Design guidelines

As a guide to the surface constructor, an aggregate grading curve which will give desired characteristics is shown in Figure 2. In addition, Table 1 gives some guidelines in order to obtain the desired texture and durability. The grading curve fits the following formula:

$$P (\% \text{ passing}) = 100 \cdot (d/d_{\max})^{1/2}$$

Where:

- d = square mesh sieve size, in mm
- d_{max} = 8 mm for the mean curve
- = 10 mm for the lower tolerance curve
- = 6.3 mm for the upper tolerance curve

Figure 2
Grading curve of the aggregate in the asphaltic mix with tolerances

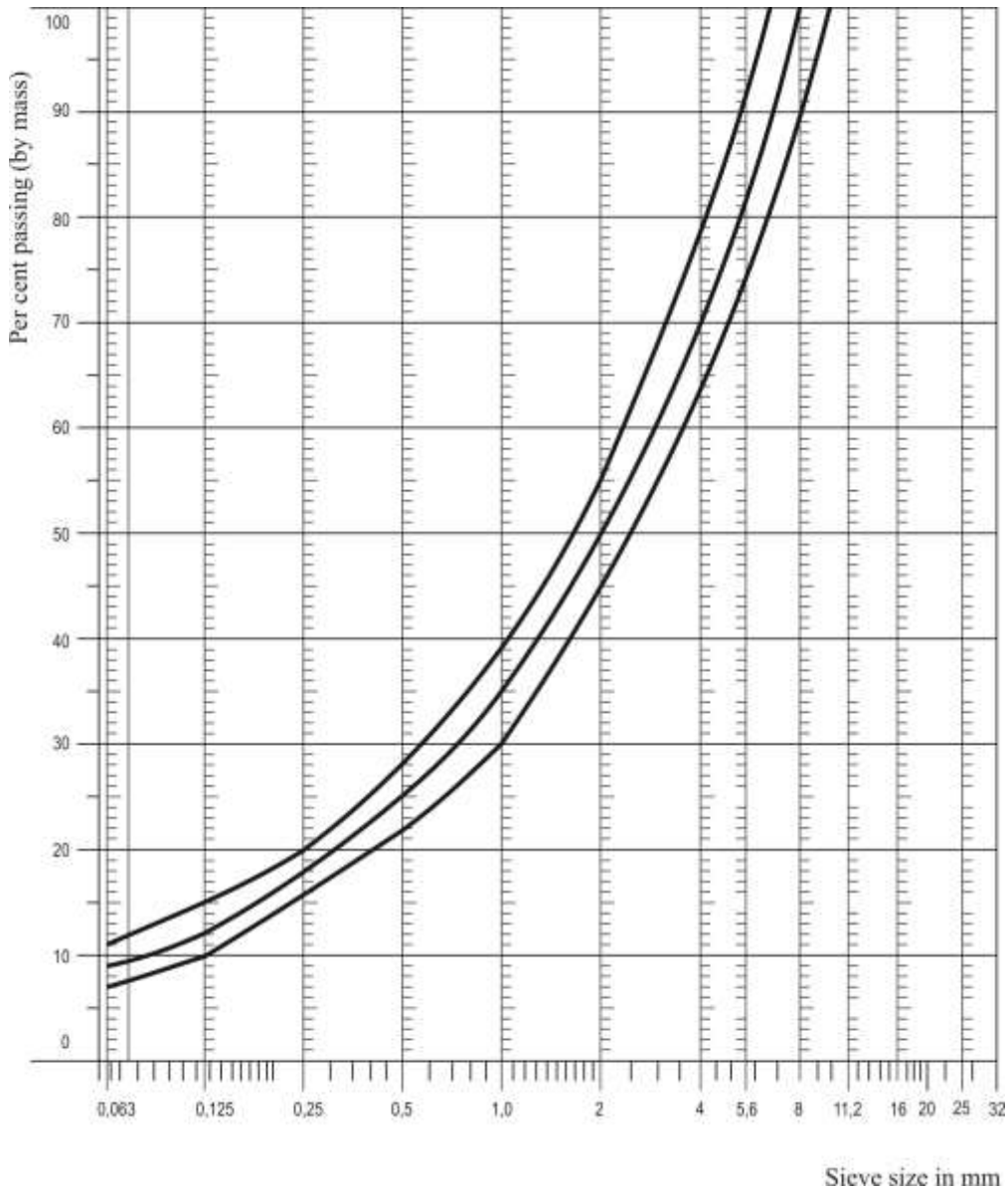

In addition to the above, the following recommendations are given:

- (a) The sand fraction (0.063 mm < square mesh sieve size < 2 mm) shall include no more than 55 per cent natural sand and at least 45 per cent crushed sand;
- (b) The base and sub-base shall ensure a good stability and evenness, according to best road construction practice;
- (c) The chippings shall be crushed (100 per cent crushed faces) and of a material with a high resistance to crushing;

- (d) The chippings used in the mix shall be washed;
- (e) No extra chippings shall be added onto the surface;
- (f) The binder hardness expressed as PEN value shall be 40 - 60, 60 - 80 or even 80 - 100 depending on the climatic conditions of the country. The rule is that as hard a binder as possible shall be used, provided this is consistent with common practice;
- (g) The temperature of the mix before rolling shall be chosen so as to achieve by subsequent rolling the required voids content. In order to increase the probability of satisfying the specifications of paragraphs 2.1. to 2.4. above, the compactness shall be studied not only by an appropriate choice of mixing temperature, but also by an appropriate number of passings and by the choice of compacting vehicle.

Table 1
Design guidelines

| | <i>Target values</i> | | <i>Tolerances</i> |
|---|-----------------------------|---------------------------------|-------------------|
| | <i>By total mass of mix</i> | <i>By mass of the aggregate</i> | |
| Mass of stones, square mesh sieve (SM) > 2 mm | 47.6 % | 50.5 % | ±5 % |
| Mass of sand 0.063 < SM < 2 mm | 38.0 % | 40.2 % | ±5 % |
| Mass of filler SM < 0.063 mm | 8.8 % | 9.3 % | ±5 % |
| Mass of binder (bitumen) | 5.8 % | N.A. | ±0.5 % |
| Max. chipping size | 8 mm | | 6.3 - 10 mm |
| Binder hardness | (see paragraph 3.2.2. (f)) | | |
| Polished Stone Value (PSV) | > 50 | | |
| Compactness, relative to Marshall Compactness | 98 % | | |

4. Test method

4.1. Measurement of the residual voids content

For the purpose of this measurement, cores have to be taken from the track in at least four different positions, which are equally distributed in the test area between lines AA and BB (see Figure 1). In order to avoid inhomogeneity and unevenness in the wheel tracks, cores should not be taken in wheel tracks themselves, but close to them. Two cores (minimum) should be taken close to the wheel tracks and one core (minimum) should be taken approximately midway between the wheel tracks and each microphone location.

If there is a suspicion that the condition of homogeneity is not met (see paragraph 2.4. above), cores shall be taken from more locations within the test area.

The residual voids content has to be determined for each core, then the average value from all cores shall be calculated and compared with the requirement of paragraph 2.1. of this annex. In addition, no single core shall have a voids value, which is higher than 10 per cent.

The test surface constructor is reminded of the problem, which may arise when the test area is heated by pipes or electrical wires and cores shall be taken from this area. Such installations shall be carefully planned with respect to future core drilling locations. It is recommended to leave a few locations of size approximately 200 mm x 300 mm where there are no wires/pipes or where the latter are located deep enough in order not to be damaged by cores taken from the surface layer.

4.2. Sound absorption coefficient

The sound absorption coefficient (normal incidence) shall be measured by the impedance tube method using the procedure specified in ISO 10534-1:1996 or ISO 10534-2:1998.

Regarding test specimens, the same requirements shall be followed as regarding the residual voids content (see paragraph 4.1. above). The sound absorption shall be measured in the range between 400 Hz and 800 Hz and in the range between 800 Hz and 1,600 Hz (at least at the centre frequencies of third octave bands) and the maximum values shall be identified for both of these frequency ranges. Then these values, for all test scores, shall be averaged to constitute the final result.

4.3. Volumetric macro-texture measurement

For the purpose of this standard, texture depth measurements shall be made on at least 10 positions evenly spaced along the wheel tracks of the test strip and the average value taken to compare with the specified minimum texture depth. See Standard ISO 10844:2014 for description of the procedure.

5. Stability in time and maintenance

5.1. Age influence

In common with any other surfaces, it is expected that the tyre rolling sound level measured on the test surface may increase slightly during the first 6-12 months after construction.

The surface will achieve its required characteristics not earlier than four weeks after construction. The influence of age on the noise from trucks is generally less than that from cars.

The stability over time is determined mainly by the polishing and compaction by vehicles driving on the surface. It shall be periodically checked as stated in paragraph 2.5. above.

5.2. Maintenance of the surface

Loose debris or dust, which could significantly reduce the effective texture depth shall be removed from the surface. In countries with winter climates, salt is sometimes used for de-icing. Salt may alter the surface temporarily or even permanently in such a way as to increase noise and is therefore not recommended.

- 5.3. Repaving the test area
- If it is necessary to repave the test track, it is usually unnecessary to repave more than the test strip (of 3 m width in Figure 1) where vehicles are driving, provided the test area outside the strip met the requirement of residual voids content or sound absorption when it was measured.
6. Documentation of the test surface and of tests performed on it
- 6.1. Documentation of the test surface
- The following data shall be given in a document describing the test surface:
- 6.1.1. The location of the test track;
- 6.1.2. Type of binder, binder hardness, type of aggregate, maximum theoretical density of the concrete (DR), thickness of the wearing course and grading curve determined from cores from the test track;
- 6.1.3. Method of compaction (e.g. type of roller, roller mass, number of passes);
- 6.1.4. Temperature of the mix, temperature of the ambient air and wind speed during laying of the surface;
- 6.1.5. Date when the surface was laid and contractor;
- 6.1.6. All or at least the latest test result, including:
- 6.1.6.1. The residual voids content of each core;
- 6.1.6.2. The locations in the test area from where the cores for voids measurements have been taken;
- 6.1.6.3. The sound absorption coefficient of each core (if measured). Specify the results both for each core and each frequency range as well as the overall average;
- 6.1.6.4. The locations in the test area from where the cores for absorption measurement have been taken;
- 6.1.6.5. Texture depth, including the number of tests and standard deviation;
- 6.1.6.6. The institution responsible for tests according to paragraphs 6.1.6.1. and 6.1.6.2. above and the type of equipment used;
- 6.1.6.7. Date of the test(s) and date when the cores were taken from the test track.
- 6.2. Documentation of vehicle noise tests conducted on the surface
- In the document describing the vehicle noise test(s) it shall be stated whether all the requirements of this standard were fulfilled or not. Reference shall be given to a document according to paragraph 6.1. above describing the results which verify this.

Annex 5

Test procedures for measuring wet grip

(A) - C1 category tyres

1. Reference standards

The following documents listed apply.

- 1.1. ASTM E 303-93 (Reapproved 2008), Standard Test Method for Measuring Surface Frictional Properties Using the British Pendulum Tester.
- 1.2. ASTM E 501-08, Standard Specification for Standard Rib Tire for Pavement Skid-Resistance Tests.
- 1.3. ASTM E 965-96 (Reapproved 2006), Standard Test Method for Measuring Pavement Macrottexture Depth Using a Volumetric Technique.
- 1.4. ASTM E 1136-93 (Reapproved 2003), Standard Specification for a Radial Standard Reference Test Tire P195/75R14.
- 1.5. ASTM F 2493-08, Standard Specification for a Radial Standard Reference Test Tire P225/60R16.

2. Definitions

For the purposes of testing wet grip of C1 tyres:

- 2.1. "*Test run*" means a single pass of a loaded tyre over a given test track surface.
- 2.2. "*Test tyre(s)*" means a candidate tyre, a reference tyre or a control tyre or tyre set that is used in a test run.
- 2.3. "*Candidate tyre(s) (T)*" means a tyre or a tyre set that is tested for the purpose of calculating its wet grip index.
- 2.4. "*Reference tyre(s) (R)*" means a tyre or a tyre set that has the characteristics indicated in the ASTM F 2493-08 and referred to as the Standard Reference Test Tyre.
- 2.5. "*Control tyre(s) (C)*" means an intermediate tyre or a set of intermediate tyres which is used when the candidate tyre and the reference tyre cannot be directly compared on the same vehicle.
- 2.6. "*Braking force of a tyre*" means the longitudinal force, expressed in newton, resulting from braking torque application.
- 2.7. "*Braking Force Coefficient of a tyre (BFC)*" means the ratio of the braking force to the vertical load.
- 2.8. "*Peak braking force coefficient of a tyre*" means the maximum value of a tyre braking force coefficient that occurs prior to wheel lockup as the braking torque is progressively increased.

- 2.9. "Lockup of a wheel" means the condition of a wheel in which its rotational velocity about the wheel spin axis is zero and it is prevented from rotating in the presence of applied wheel torque.
- 2.10. "Vertical load" means the load in newton imposed on the tyre perpendicular to the road surface.
- 2.11. "Tyre test vehicle" means a dedicated special purpose vehicle which has instruments to measure the vertical and the longitudinal forces on one test tyre during braking.
- 2.12. "SRTT14" means the ASTM E 1136-93 (Reapproved 2003), Standard Specification for a Radial Standard Reference Test Tire P195/75R14.
- 2.13. "SRTT16" means the ASTM F 2493-08, Standard Specification for a Radial Standard Reference Test Tire P225/60R16.
3. General test conditions
- 3.1. Track characteristics
- The test track shall have the following characteristics:
- 3.1.1. The surface shall have a dense asphalt surface with a uniform gradient of not more than 2 per cent and shall not deviate more than 6 mm when tested with a 3 m straight edge.
- 3.1.2. The surface shall have a pavement of uniform age, composition, and wear. The test surface shall be free of loose material and foreign deposits.
- 3.1.3. The maximum chipping size shall be 10 mm (tolerances permitted from 8 mm to 13 mm).
- 3.1.4. The texture depth as measured by a sand patch shall be 0.7 ± 0.3 mm. It shall be measured in accordance with ASTM E 965-96 (Reapproved 2006).
- 3.1.5. The wetted frictional properties of the surface shall be measured with either method (a) or (b) in paragraph 3.2.
- 3.2. Methods to measure the wetted frictional properties of the surface
- 3.2.1. British Pendulum Number (BPN) method (a)
- The British Pendulum Number method shall be as defined in ASTM E 303-93 (Reapproved in 2008).
- Pad rubber component formulation and physical properties shall be as specified in ASTM E 501-08.
- The averaged British Pendulum Number (BPN) shall be between 42 and 60 BPN after temperature correction as follows.
- BPN shall be corrected by the wetted road surface temperature. Unless temperature correction recommendations are indicated by the British pendulum manufacturer, the following formula is used:
- BPN = BPN (measured value) + temperature correction
- Temperature correction = $-0.0018 t^2 + 0.34 t - 6.1$
- Where t is the wetted road surface temperature in degrees Celsius.

Effects of slider pad wear: the pad shall be removed for maximum wear when the wear on the striking edge of the slider reaches 3.2 mm in the plane of the slider or 1.6 mm vertical to it in accordance with paragraph 5.2.2. and Figure 3 of ASTM E 303-93 (Reapproved 2008).

For the purpose of checking track surface BPN consistency for the measurement of wet grip on an instrumented passenger car: the BPN values of the test track should not vary over the entire stopping distance so as to decrease the dispersion of test results. The wetted frictional properties of the surface shall be measured five times at each point of the BPN measurement every 10 meters and the coefficient of variation of the averaged BPN shall not exceed 10 per cent.

3.2.2. ASTM E 1136 Standard Reference Test Tyre method (b)

By derogation with paragraph 2.4. above, this method uses the reference tyre that has the characteristics indicated in the ASTM E 1136-93 (Reapproved 2003) and referred to as SRTT14.

The average peak braking force coefficient ($\mu_{\text{peak,ave}}$) of the SRTT14 shall be 0.7 ± 0.1 at 65 km/h.

The average peak braking force coefficient ($\mu_{\text{peak,ave}}$) of the SRTT14 shall be corrected for the wetted road surface temperature as follows:

Peak braking force coefficient ($\mu_{\text{peak,ave}}$) = peak braking force coefficient (measured) + temperature correction

Temperature correction = $0.0035 \times (t - 20)$

Where t is the wetted road surface temperature in degrees Celsius.

3.3. Atmospheric conditions

The wind conditions shall not interfere with wetting of the surface (wind-shields are allowed).

Both the wetted surface temperature and the ambient temperature shall be between 2 °C and 20 °C for snow tyres and 5 °C and 35 °C for normal tyres.

The wetted surface temperature shall not vary during the test by more than 10 °C.

The ambient temperature must remain close to the wetted surface temperature; the difference between the ambient and the wetted surface temperatures must be less than 10 °C.

4. Testing methods for measuring wet grip

For the calculation of the wet grip index (G) of a candidate tyre, the wet grip braking performance of the candidate tyre is compared to the wet grip braking performance of the reference tyre on a vehicle travelling straight ahead on a wet, paved surface. It is measured with one of the following methods:

- (a) Vehicle method consisting of testing a set of tyres mounted on an instrumented passenger car;
- (b) Testing method using a trailer towed by a vehicle or a tyre test vehicle, equipped with the test tyre(s).

- 4.1. Testing method (a) using an instrumented passenger car
- 4.1.1. Principle
- The testing method covers a procedure for measuring the deceleration performance of C1 tyres during braking, using an instrumented passenger car equipped with an Antilock Braking System (ABS), where "instrumented passenger car" means a passenger car that is fitted with the measuring equipment listed in paragraph 4.1.2.2. below for the purpose of this testing method. Starting with a defined initial speed, the brakes are applied hard enough on four wheels at the same time to activate the ABS. The average deceleration is calculated between two pre-defined speeds.
- 4.1.2. Equipment
- 4.1.2.1. Vehicle
- Permitted modifications on the passenger car are as follows:
- (a) Those allowing the number of tyre sizes that can be mounted on the vehicle to be increased;
 - (b) Those permitting automatic activation of the braking device to be installed;
 - (c) Any other modification of the braking system is prohibited.
- 4.1.2.2. Measuring equipment
- The vehicle shall be fitted with a sensor suitable for measuring speed on a wet surface and distance covered between two speeds.
- To measure vehicle speed, a fifth wheel or non-contact speed-measuring system shall be used.
- 4.1.3. Conditioning of the test track and wetting condition
- The test track surface shall be watered at least half an hour prior to testing in order to equalize the surface temperature and water temperature. External watering should be supplied continuously throughout testing. For the whole testing area, the water depth shall be 1.0 ± 0.5 mm, measured from the peak of the pavement.
- The test track should then be conditioned by conducting at least ten test runs with tyres not involved in the test programme at 90 km/h.
- 4.1.4. Tyres and rims
- 4.1.4.1. Tyre preparation and break-in
- The test tyres shall be trimmed to remove all protuberances on the tread surface caused by mould air vents or flashes at mould junctions.
- Fit the test tyres on rims specified by a recognized tyre and rim standards organization as listed in Appendix 4 to Annex 6 to this Regulation.
- 4.1.4.2. Tyre load
- The static load on each axle tyre shall lie between 60 per cent and 90 per cent of the tested tyre load capacity. Tyre loads on the same axle should not differ by more than 10 per cent.

- 4.1.4.3. Tyre inflation pressure
On the front and rear axles, the inflation pressures shall be 220 kPa (for standard- and extra-load tyres). The tyre pressure should be checked just prior to testing at ambient temperature and adjusted if required.
- 4.1.5. Procedure
- 4.1.5.1. Test run
The following test procedure applies for each test run.
- 4.1.5.1.1. The passenger car is driven in a straight line up to 85 ± 2 km/h.
- 4.1.5.1.2. Once the passenger car has reached 85 ± 2 km/h, the brakes are always activated at the same place on the test track referred to as "braking starting point", with a longitudinal tolerance of 5 m and a transverse tolerance of 0.5 m.
- 4.1.5.1.3. The brakes are activated either automatically or manually.
- 4.1.5.1.3.1. The automatic activation of the brakes is performed by means of a detection system made of two parts, one indexed to the test track and one on board the passenger car.
- 4.1.5.1.3.2. The manual activation of the brakes depends on the type of transmission as follows. In both cases, a minimum of 600 N pedal efforts is required.

For manual transmission, the driver should release the clutch and depress the brake pedal sharply, holding it down as long as necessary to perform the measurement.

For automatic transmission, the driver should select neutral gear and then depress the brake pedal sharply, holding it down as long as necessary to perform the measurement.
- 4.1.5.1.4. The average deceleration is calculated between 80 km/h and 20 km/h.

If any of the specifications listed above (including speed tolerance, longitudinal and transverse tolerance for the braking starting point, and braking time) are not met when a test run is made, the measurement is discarded and a new test run is made.
- 4.1.5.2. Test cycle
A number of test runs are made in order to measure the wet grip index of a set of candidate tyres (T) according to the following procedure, whereby each test run shall be made in the same direction and up to three different sets of candidate tyres may be measured within the same test cycle:
- 4.1.5.2.1. First, the set of reference tyres are mounted on the instrumented passenger car.
- 4.1.5.2.2. After at least three valid measurements have been made in accordance with paragraph 4.1.5.1. above, the set of reference tyres is replaced by a set of candidate tyres.
- 4.1.5.2.3. After six valid measurements of the candidate tyres are performed, two more sets of candidate tyres may be measured.
- 4.1.5.2.4. The test cycle is closed by three more valid measurements of the same set of reference tyres as at the beginning of the test cycle.

Examples:

- (a) The run order for a test cycle of three sets of candidate tyres (T1 to T3) plus a set of reference tyres (R) would be the following:

R-T1-T2-T3-R

- (b) The run order for a test cycle of five sets of candidate tyres (T1 to T5) plus a set of reference tyres (R) would be the following:

R-T1-T2-T3-R-T4-T5-R

4.1.6. Processing of measurement results

4.1.6.1. Calculation of the Average Deceleration (AD)

The Average Deceleration (AD) is calculated for each valid test run in m/s^2 as follows:

$$AD = \left| \frac{S_f^2 - S_i^2}{2d} \right|$$

Where:

S_f is the final speed in m/s; $S_f = 20 \text{ km/h} = 5.556 \text{ m/s}$

S_i is the initial speed in m/s; $S_i = 80 \text{ km/h} = 22.222 \text{ m/s}$

d is the distance covered between S_i and S_f in meter.

4.1.6.2. Validation of results

The AD coefficient of variation is calculated as follows:

(Standard deviation / Average) x 100.

For the reference tyres (R): If the AD coefficient of variation of any two consecutive groups of three tests runs of the reference tyre set is higher than 3 per cent, all data should be discarded and the test repeated for all test tyres (the candidate tyres and the reference tyres).

For the candidate tyres (T): The AD coefficients of variation are calculated for each candidate tyre set. If one coefficient of variation is higher than 3 per cent, the data should be discarded and the test repeated for that candidate tyre set.

4.1.6.3. Calculation of adjusted average deceleration (Ra)

The Average Deceleration (AD) of the reference tyre set used for the calculation of its braking force coefficient is adjusted according to the positioning of each candidate tyre set in a given test cycle.

This adjusted AD of the reference tyre (Ra) is calculated in m/s^2 in accordance with Table 1 where R_1 is the average of the AD values in the first test of the reference tyre set (R) and R_2 is the average of the AD values in the second test of the same reference tyre set (R).

Table 1

| <i>Number of sets of candidate tyres within one test cycle</i> | <i>Set of candidate tyres</i> | <i>R_a</i> |
|--|-------------------------------|--|
| 1 (R ₁ -T1-R ₂) | T1 | R _a = 1/2 (R ₁ + R ₂) |
| 2 (R ₁ -T1-T2-R ₂) | T1 | R _a = 2/3 R ₁ + 1/3 R ₂ |
| | T2 | R _a = 1/3 R ₁ + 2/3 R ₂ |
| 3 (R ₁ -T1-T2-T3-R ₂) | T1 | R _a = 3/4 R ₁ + 1/4 R ₂ |
| | T2 | R _a = 1/2 (R ₁ + R ₂) |
| | T3 | R _a = 1/4 R ₁ + 3/4 R ₂ |

4.1.6.4. Calculation of the Braking Force Coefficient (BFC)

The Braking Force Coefficient (BFC) is calculated for a braking on the two axles according to Table 2 where T_a (a = 1, 2 or 3) is the average of the AD values for each candidate tyre (T) set that is part of a test cycle.

Table 2

| <i>Test Tyre</i> | <i>Braking force coefficient</i> |
|------------------|----------------------------------|
| Reference tyre | BFC(R) = Ra/g |
| Candidate tyre | BFC(T) = Ta/g |

g is the acceleration due to gravity, *g* = 9.81 m/s²

4.1.6.5. Calculation of the wet grip index of the candidate tyre

The wet grip index of the candidate tyre G(T) is calculated as follows:

$$G(T) = \left[\frac{BFC(T)}{BFC(R)} \times 125 + a \times (t - t_0) + b \times \left(\frac{BFC(R)}{BFC(R_0)} - 1,0 \right) \right] \times 10^{-2}$$

Where:

t is the measured wet surface temperature in degree Celsius when the candidate tyre (T) is tested

*t*₀ is the wet surface reference temperature condition, *t*₀ = 20 °C for normal tyres and *t*₀ = 10 °C for snow tyres

BFC(R₀) is the braking force coefficient for the reference tyre in the reference conditions, BFC(R₀) = 0.68

a = -0.4232 and *b* = -8.297 for normal tyres, *a* = 0.7721 and *b* = 31.18 for snow tyres [*a* is expressed as (1/°C)]

4.1.7. Wet grip performance comparison between a candidate tyre and a reference tyre using a control tyre

4.1.7.1. General

Where the candidate tyre size is significantly different from that of the reference tyre, a direct comparison on the same instrumented passenger car may not be possible. This testing method uses an intermediate tyre, hereinafter called the control tyre as defined in paragraph 2.5. above.

4.1.7.2. Principle of the approach

The principle is the use of a control tyre set and two different instrumented passenger cars for the test cycle of a candidate tyre set in comparison with a reference tyre set.

One instrumented passenger car is fitted with the reference tyre set followed by the control tyre set, the other with the control tyre set followed by the candidate tyre set.

The specifications listed in paragraphs 4.1.2. to 4.1.4. above apply.

The first test cycle is a comparison between the control tyre set and the reference tyre set.

The second test cycle is a comparison between the candidate tyre set and the control tyre set. It is done on the same test track and during the same day as the first test cycle. The wetted surface temperature shall be within ± 5 °C of the temperature of the first test cycle. The same control tyre set shall be used for the first and the second test cycles.

The wet grip index of the candidate tyre $G(T)$ is calculated as follows:

$$G(T) = G_1 \times G_2$$

Where:

G_1 is the relative wet grip index of the control tyre (C) compared to the reference tyre (R) calculated as follows:

$$G_1 = \left[\frac{\text{BFC}(C)}{\text{BFC}(R)} \times 125 + a \times (t - t_0) + b \times \left(\frac{\text{BFC}(R)}{\text{BFC}(R_0)} - 1.0 \right) \right] \times 10^{-2}$$

G_2 is the relative wet grip index of the candidate tyre (T) compared to the control tyre (C) calculated as follows:

$$G_2 = \frac{\text{BFC}(T)}{\text{BFC}(C)}$$

4.1.7.3. Storage and preservation

It is necessary that all the tyres of a control tyre set have been stored in the same conditions. As soon as the control tyre set has been tested in comparison with the reference tyre, the specific storage conditions defined in ASTM E 1136-93 (Reapproved 2003) shall be applied.

4.1.7.4. Replacement of reference tyres and control tyres

When irregular wear or damage results from tests, or when wear influences the test results, the use of the tyre shall be discontinued.

4.2. Testing method (b) using a trailer towed by a vehicle or a tyre test vehicle

4.2.1. Principle

The measurements are conducted on test tyres mounted on a trailer towed by a vehicle (hereafter referred to as tow vehicle) or on a tyre test vehicle. The brake in the test position is applied firmly until sufficient braking torque is generated to produce the maximum braking force that will occur prior to wheel lockup at a test speed of 65 km/h.

4.2.2. Equipment

4.2.2.1. Tow vehicle and trailer or tyre test vehicle

The tow vehicle or the tyre test vehicle shall have the capability of maintaining the specified speed of 65 ± 2 km/h even under the maximum braking forces.

The trailer or the tyre test vehicle shall be equipped with one place where the tyre can be fitted for measurement purposes hereafter called 'test position' and the following accessories:

- (a) Equipment to activate brakes in the test position;
- (b) A water tank to store sufficient water to supply the road surface wetting system, unless external watering is used;
- (c) Recording equipment to record signals from transducers installed at the test position and to monitor water application rate if the self-watering option is used.

The maximum variation of toe-settings and camber angle for the test position shall be within $\pm 0.5^\circ$ with maximum vertical load. Suspension arms and bushings shall have sufficient rigidity necessary to minimize free play and ensure compliance under application of maximum braking forces. The suspension system shall provide adequate load-carrying capacity and be of such a design as to isolate suspension resonance.

The test position shall be equipped with a typical or special automotive brake system which can apply sufficient braking torque to produce the maximum value of braking test wheel longitudinal force at the conditions specified.

The brake application system shall be able to control the time interval between initial brake application and peak longitudinal force as specified in paragraph 4.2.7.1. below.

The trailer or the tyre test vehicle shall be designed to accommodate the range of candidate tyre sizes to be tested.

The trailer or the tyre test vehicle shall have provisions for adjustment of vertical load as specified in paragraph 4.2.5.2. below

4.2.2.2. Measuring equipment

The test wheel position on the trailer or the tyre test vehicle shall be equipped with a rotational wheel velocity measuring system and with transducers to measure the braking force and vertical load at the test wheel.

General requirements for measurement system: The instrumentation system shall conform to the following overall requirements at ambient temperatures between 0 °C and 45 °C:

- (a) Overall system accuracy, force: ± 1.5 per cent of the full scale of the vertical load or braking force;
- (b) Overall system accuracy, speed: ± 1.5 per cent of speed or ± 1.0 km/h, whichever is greater.

Vehicle speed: To measure vehicle speed, a fifth wheel or non-contact precision speed-measuring system should be used.

Braking forces: The braking force-measuring transducers shall measure longitudinal force generated at the tyre-road interface as a result of brake application within a range from 0 per cent to at least 125 per cent of the applied vertical load. The transducer design and location shall minimize inertial effects and vibration-induced mechanical resonance.

Vertical load: The vertical load-measuring transducer shall measure the vertical load at the test position during brake application. The transducer shall have the same specifications as described previously.

Signal conditioning and recording system: All signal conditioning and recording equipment shall provide linear output with necessary gain and data reading resolution to meet the specified previous requirements. In addition, the following requirements apply:

- (a) The minimum frequency response shall be flat from 0 Hz to 50 Hz (100 Hz) within ± 1 per cent full scale;
- (b) The signal-to-noise ratio shall be at least 20/1;
- (c) The gain shall be sufficient to permit full-scale display for full-scale input signal level;
- (d) The input impedance shall be at least ten times larger than the output impedance of the signal source;
- (e) The equipment shall be insensitive to vibrations, acceleration, and changes in ambient temperature.

4.2.3. Conditioning of the test track

The test track should be conditioned by conducting at least ten test runs with tyres not involved in the test program at 65 ± 2 km/h.

4.2.4. Wetting conditions

The tow vehicle and trailer or the tyre test vehicle may be optionally equipped with a pavement-wetting system, less the storage tank, which, in the case of the trailer, is mounted on the tow vehicle. The water being applied to the pavement ahead of the test tyres shall be supplied by a nozzle suitably designed to ensure that the water layer encountered by the test tyre has a uniform cross section at the test speed with a minimum splash and overspray.

The nozzle configuration and position shall ensure that the water jets are directed towards the test tyre and pointed towards the pavement at an angle of 20° to 30°.

The water shall strike the pavement 250 mm to 450 mm ahead of the centre of tyre contact. The nozzle shall be located 25 mm above the pavement or at the minimum height required to clear obstacles which the tester is expected to encounter, but in no case more than 100 mm above the pavement.

The water layer shall be at least 25 mm wider than the test tyre tread and applied so the tyre is centrally located between the edges. Water delivery rate shall ensure a water depth of 1.0 ± 0.5 mm and shall be consistent throughout the test to within ± 10 per cent. The volume of water per unit of wetted width shall be directly proportional to the test speed. The quantity of water applied at 65 km/h shall be 18 l/s per meter of width of wetted surface in case of a water depth of 1.0 mm.

4.2.5. Tyres and rims

4.2.5.1. Tyre preparation and break-in

The test tyres shall be trimmed to remove all protuberances on the tread surface caused by mould air vents or flashes at mould junctions.

The test tyre shall be mounted on the test rim declared by the tyre manufacturer.

A proper bead seat should be achieved by the use of a suitable lubricant. Excessive use of lubricant should be avoided to prevent slipping of the tyre on the wheel rim.

The test tyres/rim assemblies shall be stored in a location for a minimum of two hours such that they all have the same ambient temperature prior to testing. They should be shielded from the sun to avoid excessive heating by solar radiation.

For tyre break-in, two braking runs shall be performed under the load, pressure and speed as specified in paragraphs 4.2.5.2, 4.2.5.3 and 4.2.7.1 respectively.

4.2.5.2. Tyre load

The test load on the test tyre is 75 ± 5 per cent of the tyre load capacity.

4.2.5.3. Tyre inflation pressure

The test tyre cold inflation pressure shall be 180 kPa for standard-load tyres. For extra-load tyres, the cold inflation pressure shall be 220 kPa.

The tyre pressure should be checked just prior to testing at ambient temperature and adjusted if required.

- 4.2.6. Preparation of the tow vehicle and trailer or the tyre test vehicle
 - 4.2.6.1. Trailer

For one axle trailers, the hitch height and transverse position shall be adjusted once the test tyre has been loaded to the specified test load in order to avoid any disturbance of the measuring results. The longitudinal distance from the centre line of the articulation point of the coupling to the transverse centre line of the axle of the trailer shall be at least ten times the "hitch height" or the "coupling (hitch) height".
 - 4.2.6.2. Instrumentation and equipment

Install the fifth wheel, when used, in accordance with the manufacturer's specifications and locate it as near as possible to the mid-track position of the tow trailer or the tyre test vehicle.
- 4.2.7. Procedure
 - 4.2.7.1. Test run

The following procedure applies for each test run:

 - 4.2.7.1.1. The tow vehicle or the tyre test vehicle is driven onto the test track in a straight line at the specified test speed 65 ± 2 km/h.
 - 4.2.7.1.2. The recording system is launched.
 - 4.2.7.1.3. Water is delivered to the pavement ahead of the test tyre approximately 0.5 s prior to brake application (for internal watering system).
 - 4.2.7.1.4. The trailer brakes are activated within 2 meters of a measurement point of the wetted frictional properties of the surface and sand depth in accordance with paragraphs 3.1.4. and 3.1.5. above. The rate of braking application shall be such that the time interval between initial application of force and peak longitudinal force is in the range 0.2 s to 0.5 s.
 - 4.2.7.1.5. The recording system is stopped.
 - 4.2.7.2. Test cycle

A number of test runs are made in order to measure the wet grip index of the candidate tyre (T) according to the following procedure, whereby each test run shall be made from the same spot on the test track and in the same direction. Up to three candidate tyres may be measured within the same test cycle, provided that the tests are completed within one day.

 - 4.2.7.2.1. First, the reference tyre is tested.
 - 4.2.7.2.2. After at least six valid measurements are performed in accordance with paragraph 4.2.7.1. above, the reference tyre is replaced by the candidate tyre.
 - 4.2.7.2.3. After six valid measurements of the candidate tyre are performed, two more candidate tyres may be measured.
 - 4.2.7.2.4. The test cycle is closed by six more valid measurements of the same reference tyre as at the beginning of the test cycle.

Examples:

- (a) The run order for a test cycle of three candidate tyres (T1 to T3) plus the reference tyre (R) would be the following:

R-T1-T2-T3-R

- (b) The run order for a test cycle of five candidate tyres (T1 to T5) plus the reference tyre R would be the following:

R-T1-T2-T3-R-T4-T5-R

4.2.8. Processing of measurement results

4.2.8.1. Calculation of the peak braking force coefficient

The tyre peak braking force coefficient (μ_{peak}) is the highest value of $\mu(t)$ before lockup occurs calculated as follows for each test run. Analogue signals should be filtered to remove noise. Digitally recorded signals must be filtered using a moving average technique.

$$\mu(t) = \frac{|fh(t)|}{|fv(t)|}$$

Where:

$\mu(t)$ is the dynamic tyre braking force coefficient in real time;

$fh(t)$ is the dynamic braking force in real time, in N;

$fv(t)$ is the dynamic vertical load in real time, in N.

4.2.8.2. Validation of results

The μ_{peak} coefficient of variation is calculated as follows:

(Standard deviation / Average) x 100

For the reference tyre (R): If the coefficient of variation of the peak braking force coefficient (μ_{peak}) of the reference tyre is higher than 5 per cent, all data should be discarded and the test repeated for all test tyres (the candidate tyre(s) and the reference tyre).

For the candidate tyre(s) (T): The coefficient of variation of the peak braking force coefficient (μ_{peak}) is calculated for each candidate tyre. If one coefficient of variation is higher than 5 per cent, the data should be discarded and the test repeated for this candidate tyre.

4.2.8.3. Calculation of the adjusted average peak braking force coefficient

The average peak braking force coefficient of the reference tyre used for the calculation of its braking force coefficient is adjusted according to the positioning of each candidate tyre in a given test cycle.

This adjusted average peak braking force coefficient of the reference tyre (R_a) is calculated in accordance with Table 3 where R_1 is the average peak tyre braking coefficient in the first test of the reference tyre (R) and R_2 is the average peak tyre braking coefficient in the second test of the same reference tyre (R).

Table 3

| Number of candidate tyre(s) within one test cycle | Candidate tyre | Ra |
|---|----------------|--|
| 1 (R1-T1-R2) | T1 | Ra = 1/2 (R ₁ + R ₂) |
| 2 (R1-T1-T2-R2) | T1 | Ra = 2/3 R ₁ + 1/3 R ₂ |
| | T2 | Ra = 1/3 R ₁ + 2/3 R ₂ |
| 3 (R1-T1-T2-T3-R2) | T1 | Ra = 3/4 R ₁ + 1/4 R ₂ |
| | T2 | Ra = 1/2 (R ₁ + R ₂) |
| | T3 | Ra = 1/4 R ₁ + 3/4 R ₂ |

4.2.8.4 Calculation of the average peak braking coefficient ($\mu_{\text{peak,ave}}$)

The average value of the peak braking coefficients ($\mu_{\text{peak,ave}}$) is calculated according to Table 4 whereby Ta (a = 1, 2 or 3) is the average of the peak braking force coefficients measured for one candidate tyre within one test cycle.

Table 4

| Test tyre | $\mu_{\text{peak,ave}}$ |
|----------------|--|
| Reference tyre | $\mu_{\text{peak,ave}}(\text{R}) = \text{Ra}$ as per Table 3 |
| Candidate tyre | $\mu_{\text{peak,ave}}(\text{T}) = \text{Ta}$ |

4.2.8.5. Calculation of the wet grip index of the candidate tyre

The wet grip index of the candidate tyre (G(T)) is calculated as follows:

$$G(\text{T}) = \left[\frac{\mu_{\text{peak,ave}}(\text{T})}{\mu_{\text{peak,ave}}(\text{R})} \times 125 + a \times (t - t_0) + b \times \left(\frac{\mu_{\text{peak,ave}}(\text{R})}{\mu_{\text{peak,ave}}(\text{R}_0)} - 1.0 \right) \right] \times 10^{-2}$$

Where:

t is the measured wet surface temperature in degree Celsius when the candidate tyre (T) is tested

t₀ is the wet surface reference temperature condition

t₀ = 20 °C for normal tyres t₀=10°C for snow tyres

$\mu_{\text{peak,ave}}(\text{R}_0) = 0.85$ is the peak braking force coefficient for the reference tyre in the reference conditions

a = -0.4232 and b = -8.297 for normal tyres, a = 0.7721 and b = 31.18 for snow tyres [a is expressed as (1/°C)].

(B) – C2 and C3 category tyres

1. General test conditions

1.1. Track characteristics

The surface shall be a dense asphalt surface with a uniform gradient of not more than two per cent and shall not deviate more than 6 mm when tested with a 3 m straight edge.

The test surface shall have a pavement of uniform age, composition, and wear. The test surface shall be free of loose material or foreign deposits.

The maximum chipping size shall be from 8 mm to 13 mm.

The sand depth measured as specified in EN13036-1:2001 and ASTM E 965-96 (reapproved 2006) shall be 0.7 ± 0.3 mm.

The surface friction value for the wetted track shall be established by one or other of the following methods according to the discretion of the Contracting Party.

1.1.1. Standard Reference Test Tyre (SRTT) method

The average peak braking coefficient (μ peak average) of the ASTM E1136 - 93 (reapproved 2003) reference tyre (Test method using a trailer or a tyre test vehicle as specified in clause 2.1) shall be 0.7 ± 0.1 (at 65 km/h and 180 kPa). The measured values shall be corrected for the effects of temperature as follows:

$$pbfc = pbfc \text{ (measured)} + 0.0035 \cdot (t - 20)$$

Where "t" is the wetted track surface temperature in degrees Celsius.

The test shall be conducted using the lanes and length of the track to be used for the wet grip test.

For the trailer method, testing is run in such a way that braking occurs within 10 meters distance of where the surface was characterized.

1.1.2. British Pendulum Number (BPN) method

The averaged British Pendulum Number (BPN) British Pendulum Tester method as specified in ASTM E 303-93 (reapproved 2008) using the Pad as specified in ASTM E 501-08 shall be (50 ± 10) BPN after temperature correction.

BPN shall be corrected by the wetted road surface temperature. Unless temperature correction recommendations are indicated by the British pendulum manufacturer the following formula can be used:

$$BPN = BPN \text{ (measured value)} - (0.0018 \cdot t^2) + 0.34 \cdot t - 6.1$$

Where: "t" is the wetted road surface temperature in degrees Celsius.

Effects of slider pad wear: the pad should be removed for maximum wear when the wear on the striking edge of the slider reaches 3.2 mm in the plane of the slider or 1.6 mm vertical to it.

Check the test track testing surface BPN consistency for the measurement of wet grip on a standard vehicle.

In the lanes of the track to be used during the wet grip tests, the BPN shall be measured at intervals of 10 m along the length of the lanes. The BPN shall be measured 5 times at each point and the coefficient of variation of the BPN averages shall not exceed 10 per cent.

1.1.3. The Type Approval Authority shall satisfy itself of the characteristics of the track on the basis of evidence produced in test reports.

1.2. The surface may be wetted from the track-side or by a wetting system incorporated into the test vehicle or the trailer.

If a track-side system is used, the test surface shall be wetted for at least half an hour prior to testing in order to equalize the surface temperature and water temperature. It is recommended that track-side wetting be continuously applied throughout testing.

The water depth shall be between 0.5 and 2.0 mm.

1.3. The wind conditions shall not interfere with wetting of the surface (wind-shields are permitted).

The ambient and the wetted surface temperature shall be between 5 °C and 35 °C and shall not vary during the test by more than 10 °C.

1.4. In order to cover the range of the tyre sizes fitting the commercial vehicles, three Standard Reference Testing Tyre (SRTT) sizes shall be used to measure the relative wet index:

- (a) SRTT 315/70R22.5 LI=154/150, ASTM F2870
- (b) SRTT 245/70R19.5 LI=136/134, ASTM F2871
- (c) SRTT 225/75 R 16 C LI=116/114, ASTM F2872

The three standard reference testing tyre sizes shall be used to measure the relative wet index as shown in the following table:

| <i>For C3 tyres</i> | |
|--|---|
| Narrow family $S_{\text{Nominal}} < 285 \text{ mm}$ | Wide family $S_{\text{Nominal}} \geq 285 \text{ mm}$ |
| SRTT 245/70R19.5 LI=136/134 | SRTT 315/70R22.5 LI=154/150 |
| <i>For C2 tyres</i> | |
| SRTT 225/75 R 16 C LI=116/114 | |
| $S_{\text{Nominal}} = \text{Tyre nominal section width}$ | |

2. Test procedure

The comparative wet grip performance shall be established using either:

- (a) A trailer or special purpose tyre evaluation vehicle; or
- (b) A standard production vehicle (M₂, M₃, N₁, N₂ or N₃ category) as defined in the Consolidated Resolution on the Construction of Vehicles (R.E.3.) contained in ECE/TRANS/WP.29/78/Rev.4, para. 2.

2.1. Trailer or special purpose tyre evaluation vehicle procedure

2.1.1. The measurements are conducted on (a) tyre(s) mounted on a trailer towed by a vehicle or a tyre test vehicle.

The brake on the test position is applied firmly until sufficient braking torque results to produce maximum braking force that will occur prior to wheel lockup at a test speed of 50 km/h. The trailer, together with the towing vehicle, or the tyre evaluation vehicle shall comply with the following requirements:

- 2.1.1.1. Be capable of exceeding the upper limit for the test speed of 50 km/h and of maintaining the test speed requirement of (50 ± 2) km/h even at the maximum level of application of braking forces;
- 2.1.1.2. Be equipped with an axle providing one test position having an hydraulic brake and actuation system that can be operated at the test position from the towing vehicle if applicable. The braking system shall be capable of providing sufficient braking torque to achieve the peak brake force coefficient over the range of tyre sizes and tyre loads to be tested;
- 2.1.1.3. Be capable of maintaining longitudinal alignment (toe) and camber of the test wheel and tyre assembly throughout the test within $\pm 0.5^\circ$ of the static figures achieved at the test tyre loaded condition;
- 2.1.1.4. In the case a track wetting system is incorporated:

The system shall be able to deliver the water such that the tyre and track surface in front of the tyre are wetted before the start of braking and throughout the duration of the test. The apparatus may be optionally equipped with a pavement-wetting system, less the storage tank, which, in the case of the trailer, is mounted on the tow vehicle. The water being applied to the pavement ahead of the test tyres shall be supplied by a nozzle suitably designed to ensure that the water layer encountered by the test tyre has a uniform cross section at the test speed with a minimum splash and overspray.

The nozzle configuration and position shall ensure that the water jets shall be directed toward the test tyre and pointed toward the pavement at an angle of 15 to 30°. The water shall strike the pavement 0.25 to 0.5 m ahead of the centre of tyre contact. The nozzle shall be located 100 mm above the pavement or the minimum height required to clear obstacles which the tester is expected to encounter, but in no case more than 200 mm above the pavement. The water layer shall be at least 25 mm wider than the test tyre tread and applied so the tyre is centrally located between the edges. The volume of water per unit of wetted width shall be directly proportional to the test speed. The quantity of water applied at 50 km/h shall be 14 l/s per meter of the width of the wetted surface. The nominal values of rate of water application shall be maintained within ± 10 per cent.

- 2.1.2. Test procedure

- 2.1.2.1. Fit the test tyres on rims specified by a recognized tyre and rim standards organization as listed in Appendix 4 to Annex 6 to this Regulation. Ensure proper bead seating by the use of a suitable lubricant. Excessive use of lubricant should be avoided to prevent slipping of the tyre on the wheel rim.

Check the test tyres for the specified inflation pressure at ambient temperature (cold), just prior to testing. For the purpose of this standard the testing tyre cold inflation pressure P_t shall be calculated as follows:

$$P_t = P_r \times \left(\frac{Q_t}{Q_r} \right)^{1.25}$$

Where:

P_r = Inflation pressure marked on the sidewall. If P_r is not marked on the sidewall refer to the specified pressure in applicable tyre standards manuals corresponding to maximum load capacity for single applications

Q_t = The static test load of the tyre

Q_r = The maximum mass associated with the load capacity index of the tyre

- 2.1.2.2. For tyre break-in, two braking runs are performed. The tyre shall be conditioned for a minimum of two hours adjacent to the test track such that it is stabilized at the ambient temperature of the test track area. The tyre(s) shall not be exposed to direct sunshine during conditioning.
- 2.1.2.3. The load conditions for testing shall be 75 ± 5 per cent of the value corresponding to the load index.
- 2.1.2.4. Shortly before testing, the track shall be conditioned by carrying out at least ten braking test runs at 50 km/h on the part of the track to be used for the performance test programme but using a tyre not involved in that programme;
- 2.1.2.5. Immediately prior to testing, the tyre inflation pressure shall be checked and reset, if necessary, to the values given in paragraph 2.1.2.1.
- 2.1.2.6. The test speed shall be at 50 ± 2 km/h and shall be maintained between these limits throughout the test run.
- 2.1.2.7. The direction of the test shall be the same for each set of tests and shall be the same for the test tyre as that used for the SRTT with which its performance is to be compared.
- 2.1.2.8. Deliver water to the pavement ahead of the test tyre approximately 0.5 s prior to brake application (for internal watering system). The brakes of the test wheel assembly shall be applied such that peak braking force is achieved within 0.2 s and 1.0 s of brake application.
- 2.1.2.9. For new tyres, the first two braking runs are discarded for tyre break-in.
- 2.1.2.10. For the evaluation of the performance of any tyre compared with that of the SRTT, the braking test should be run at the same area on the test pad.
- 2.1.2.11. The order of testing shall be:

R1 - T - R2

Where:

R1 = the initial test of the SRTT,

R2 = the repeat test of the SRTT and

T = the test of the candidate tyre to be evaluated.

A maximum of three candidate tyres may be tested before repeating the SRTT test, for example:

R1 - T1 - T2 - T3 - R2

2.1.2.12. Calculate the peak braking force coefficient, μ_{peak} , for each test using the following equation:

$$\mu(t) = \left| \frac{f_h(t)}{f_v(t)} \right| \quad (1)$$

Where:

$\mu(t)$ = dynamic tyre braking force coefficient in real time,

$f_h(t)$ = dynamic braking force in real time, N,

$f_v(t)$ = dynamic vertical load in real time, N

Using equation (1) for dynamic tyre braking force coefficient, calculate the peak tyre braking force coefficient, μ_{peak} , by determining the highest value of $\mu(t)$ before lockup occurs. Analogic signals should be filtered to remove noise. Digitally recorded signals may be filtered using a moving average technique.

Calculate the average values of peak-braking coefficient ($\mu_{\text{peak, ave}}$) by averaging four or more valid repeated runs for each set of test and reference tyres for each test condition provided that the tests are completed within the same day.

2.1.2.13. Validation of results

For the reference tyre:

If the coefficient of variation of the peak braking coefficient, which is calculated by "standard deviation/average x 100" of the reference tyre is higher than five per cent, discard all data and repeat the test for this reference tyre.

For the candidate tyres:

The coefficients of variation (standard deviation/average x 100) are calculated for all the candidate tyres. If one coefficient of variation is greater than five per cent, discard the data for this candidate tyre and repeat the test.

If R_1 is the average of the peak braking coefficient in the first test of the reference tyre, R_2 is the average of the peak braking coefficient in the second test of the reference tyre, the following operations are performed, according to the following table:

| <i>If the number of sets of candidate tyres between two successive runs of the reference tyre is:</i> | <i>and the set of candidate tyres to be qualified is:</i> | <i>then "Ra" is calculated by applying the following:</i> |
|---|---|---|
| 1 $R_1 - T_1 - R_2$ | T1 | $R_a = 1/2 (R_1 + R_2)$ |
| 2 $R_1 - T_1 - T_2 - R_2$ | T1 T2 | $R_a = 2/3 R_1 + 1/3 R_2$ $R_a = 1/3 R_1 + 2/3 R_2$ |
| 3 $R_1 - T_1 - T_2 - T_3 - R_2$ | T1 T2 T3 | $R_a = 3/4 R_1 + 1/4 R_2$ $R_a = 1/2 (R_1 + R_2)$ $R_a = 1/4 R_1 + 3/4 R_2$ |

- 2.1.2.14. The wet grip index (G) shall be calculated as:
Wet grip index (G) = $\mu_{\text{peak,ave}}(T)/\mu_{\text{peak,ave}}(R)$
It represents the relative Wet Grip Index for braking performance of the candidate tyre (T) compared to the reference tyre (R).
- 2.2. Standard vehicle procedure
- 2.2.1. The vehicle used shall have two axles and be equipped with an anti-lock braking system (e.g. standard production vehicle of M₂, M₃, N₁, N₂ or N₃ category). The ABS shall continue to fulfil the utilisation of adhesion requirements defined in the Regulations as appropriate, and shall be comparable and constant throughout the tests with the different tyres mounted.
- 2.2.1.1. Measuring equipment
The vehicle shall be fitted with a sensor suitable for measuring speed on a wet surface and distance covered between two speeds.
To measure vehicle speed, a fifth wheel or non-contact speed-measuring system shall be used.
The following tolerances shall be respected:
(a) For the speed measurements: ± 1 per cent or ± 0.5 km/h whichever is greater;
(b) For the distance measurements: $\pm 1 \times 10^{-1}$ m.
A display of the measured speed or the difference between the measured speed and the reference speed for the test can be used inside the vehicle so that the driver can adjust the speed of the vehicle.
A data acquisition system can be also used for storing the measurements.
- 2.2.2. Test procedure
Starting with a defined initial speed, the brakes are applied hard enough on the two axles at the same time to activate the ABS system.
- 2.2.2.1. The Average Deceleration (AD) is calculated between two defined speeds, with an initial speed of 60 km/h and a final speed of 20 km/h.
- 2.2.2.2. Vehicle equipment
The rear axle may be indifferently fitted with 2 or 4 tyres.
For the reference tyre testing, both axles are fitted with reference tyres. (A total of 4 or 6 reference tyres depending on the choice above mentioned).
For the candidate tyre testing, 3 fitting configurations are possible:
(a) Configuration "Configuration 1": Candidate tyres on front and rear axles: it is the standard configuration that should be used every time it is possible.
(b) Configuration "Configuration 2": Candidate tyres on front axle and reference tyre or control tyre on rear axle: allowed in such cases where fitting the candidate tyre on the rear position is not possible.

- (c) Configuration "Configuration 3": Candidate tyres on rear axle and reference tyre or control tyre on front axle; permitted in such cases where fitting the candidate tyre on the front position is not possible.

2.2.2.3. Tyre inflation pressure

- (a) For a vertical load higher or equal to 75 per cent of the load capacity of the tyre, the test inflation pressure " P_t " shall be calculated as follows:

$$P_t = P_r \cdot (Q_t/Q_r)^{1.25}$$

P_r = Inflation pressure marked on the sidewall. If P_r is not marked on the sidewall refer to the specified pressure in applicable tyre standards manuals corresponding to maximum load capacity for single applications

Q_t = static test load of the tyre

Q_r = maximum mass associated with the load capacity index of the tyre

- (b) For a vertical load lower than 75 per cent of the load capacity of the tyre, the test inflation pressure P_t shall be calculated as follows:

$$P_t = P_r \cdot (0.75)^{1.25} = (0.7) \cdot P_r$$

P_r = Inflation pressure marked on the sidewall.

If P_r is not marked on the sidewall refer to the specified pressure in applicable tyre standard manuals corresponding to maximum load capacity for single applications.

Check the tyre pressure just prior to testing at ambient temperature.

2.2.2.4. Tyre load

The static load on each axle shall remain the same throughout the test procedure. The static load on each tyre shall lie between 60 per cent and 100 per cent of the candidate tyre's load capacity. This value shall not exceed 100 per cent of the load capacity of the reference tyre.

Tyre load on the same axle should not differ by more than 10 per cent.

The use of fitting as per Configurations 2 and 3 shall fulfil the following additional requirements:

Configuration 2: Front axle load > Rear axle load

The rear axle may be indifferently fitted with 2 or 4 tyres

Configuration 3: Rear axle load > Front axle load x 1.8

2.2.2.5. Tyre preparation and break-in

- 2.2.2.5.1. The test tyre shall be mounted on the test rim declared by the tyre manufacturer.

Ensure proper bead seating by the use of a suitable lubricant. Excessive use of lubricant should be avoided to prevent slipping of the tyre on the wheel rim.

- 2.2.2.5.2. Place the fitted test tyres in a location for a minimum of two hours such that they all have the same ambient temperature prior to testing, and shield them from the sun to avoid excessive heating by solar radiation. For tyre break-in, perform two braking runs.
- 2.2.2.5.3. Condition the pavement by conducting at least ten test runs with tyres not involved in the test programme at an initial speed higher or equal to 65 km/h (which is higher than the initial test speed to guarantee that a sufficient length of track is conditioned).
- 2.2.2.6. Procedure
- 2.2.2.6.1. First, mount the set of reference tyres on the vehicle.
- The vehicle accelerates in the starting zone up to 65 ± 2 km/h.
- Activation of the brakes on the track is made always at the same place with a tolerance of 5 meters in longitudinal and 0.5 meters in transverse.
- 2.2.2.6.2. According to the type of transmission, two cases are possible:
- (a) Manual transmission
- As soon as the driver is in the measuring zone and having reached 65 ± 2 km/h, the clutch is released and the brake pedal depressed sharply, holding it down as long as necessary to perform the measurement.
- (b) Automatic transmission
- As soon as the driver is in the measuring zone and having reached 65 ± 2 km/h, select neutral gear and then the brake pedal is depressed sharply, holding it down as long as necessary to perform the measurement.
- Automatic activation of the brakes can be performed by means of a detection system made of two parts, one indexed to the track and one embarked on the vehicle. In that case braking is made more rigorously at the same portion of the track.
- If any of the above-mentioned conditions are not met when a measurement is made (speed tolerance, braking time, etc.), the measurement is discarded and a new measurement is made.
- 2.2.2.6.3. Test running order
- Examples:
- The run order for a test of 3 sets of candidate tyres (T1 to T3) plus a reference tyre R would be:
- R - T1 - T2 - T3 - R
- The run order for a test of 5 sets of tyres (T1 to T5) plus a reference tyre R would be:
- R - T1 - T2 - T3 - R - T4 - T5 - R
- 2.2.2.6.4. The direction of the test shall be the same for each set of tests and shall be the same for the candidate test tyre as that used for the SRTT with which its performance is to be compared.

- 2.2.2.6.5. For each test and for new tires, the first two braking measurements are discarded.
- 2.2.2.6.6. After at least 3 valid measurements have been made in the same direction, the reference tyres are replaced by a set of the candidate tyres (one of the 3 configurations presented in paragraph 2.2.2.2.) and at least 6 valid measurements shall be performed.
- 2.2.2.6.7. A maximum of three sets of candidate tyres can be tested before the reference tyre is re-tested.

2.2.2.7. Processing of measurement results

2.2.2.7.1. Calculation of the Average Deceleration (AD)

Each time the measurement is repeated, the average deceleration AD [$\text{m}\cdot\text{s}^{-2}$] is calculated by:

$$AD = \left| \frac{S_f^2 - S_i^2}{2d} \right|$$

Where d [m] is the distance covered between the initial speed S_i [$\text{m}\cdot\text{s}^{-1}$] and the final speed S_f [$\text{m}\cdot\text{s}^{-1}$].

2.2.2.7.2. Validation of results

For the reference tyre:

If the coefficient of variation of "AD" of any two consecutive groups of 3 runs of the reference tyre is higher than 3 per cent, discard all data and repeat the test for all tyres (the candidate tyres and the reference tyre). The coefficient of variation is calculated by the following relation:

$$\frac{\text{standard deviation}}{\text{average}} \times 100$$

For the candidate tyres:

The coefficients of variation are calculated for all the candidate tyres.

$$\frac{\text{standard deviation}}{\text{average}} \times 100$$

If one coefficient of variation is greater than 3 per cent, discard the data for this candidate tyre and repeat the test.

2.2.2.7.3. Calculation of the "average AD"

If R_1 is the average of the AD values in the first test of the reference tyre and R_2 is the average of the AD values in the second test of the reference tyre, the following operations are performed, according to Table 5.

R_a is the adjusted average AD of the reference tyre.

Table 5

| <i>Number of sets of candidate tyres between two successive runs of the reference tyre</i> | <i>Set of candidate tyres to be qualified</i> | <i>R_a</i> |
|--|---|---------------------------|
| 1 R1-T1-R2 | T1 | $R_a = 1/2 (R_1 + R_2)$ |
| 2 R1-T1-T2-R2 | T1 | $R_a = 2/3 R_1 + 1/3 R_2$ |
| | T2 | $R_a = 1/3 R_1 + 2/3 R_2$ |
| 3 R1-T1-T2-T3-R2 | T1 | $R_a = 3/4 R_1 + 1/4 R_2$ |
| | T2 | $R_a = 1/2 (R_1 + R_2)$ |
| | T3 | $R_a = 1/4 R_1 + 3/4 R_2$ |

2.2.2.7.4. Calculation of braking force coefficient, BFC

BFC(R) and BFC(T) are calculated according to Table 6:

Table 6

| <i>Tyre type</i> | <i>Braking force coefficient is</i> |
|--|-------------------------------------|
| Reference tyre | $BFC(R) = R_a/g$ |
| Candidate tyre | $BFC(T) = T_a/g$ |
| g is the acceleration due to gravity (rounded to 9.81 m·s ⁻²). | |

T_a (a = 1, 2, etc.) is the average of the AD values for a test of a candidate tyre.

2.2.2.7.5. Calculation of the relative wet grip performance index of the tyre

The Wet grip index represents the relative performance of the candidate tyre compared to the reference tyre. The way to obtain it depends on the test configuration as defined in paragraph 2.2.2.2. of this annex. The wet grip index of the tyre is calculated as reported into Table 7:

Table 7

| | |
|--|---|
| Configuration C1: candidate tyres on both axles | $\text{Wet Grip Index} = \frac{BFC(T)}{BFC(R)}$ |
| Configuration C2: candidate tyres on front axle and reference tyres on rear axle | $\text{Wet Grip Index} = \frac{BFC(T) \times [a + b + h \times BFC(R)] - a \times BFC(R)}{BFC(R) \times [b + h \times BFC(T)]}$ |
| Configuration C3: reference tyres on front axle and candidate tyres on rear axle | $\text{Wet Grip Index} = \frac{BFC(T) \times [-a - b + h \times BFC(R)] + b \times BFC(R)}{BFC(R) \times [-a + h \times BFC(T)]}$ |

Where:

"G": centre of gravity of the loaded vehicle

"m": mass (in kilograms) of the loaded vehicle

- "a": horizontal distance between front axle and centre of gravity of the loaded vehicle (m)
 - "b": horizontal distance between rear axle and centre of gravity of the loaded vehicle
 - "h": vertical distance between ground level and centre of gravity of the loaded vehicle (m).
- N.B.* When "h" is not precisely known, these worst case values shall apply:
1.2 for configuration C2, and 1.5 for configuration C3
- " γ " loaded vehicle acceleration [$\text{m}\cdot\text{s}^{-2}$]
 - "g" acceleration due to the gravity [$\text{m}\cdot\text{s}^{-2}$]
 - "X1" longitudinal (X-direction) reaction of the front tyre on the road
 - "X2" longitudinal (X-direction) reaction of the rear tyre on the road
 - "Z1" normal (Z-direction) reaction of the front tyre on the road
 - "Z2" normal (Z-direction) reaction of the rear tyre on the road

Figure 1

Nomenclature explanation related to grip index of the tyre

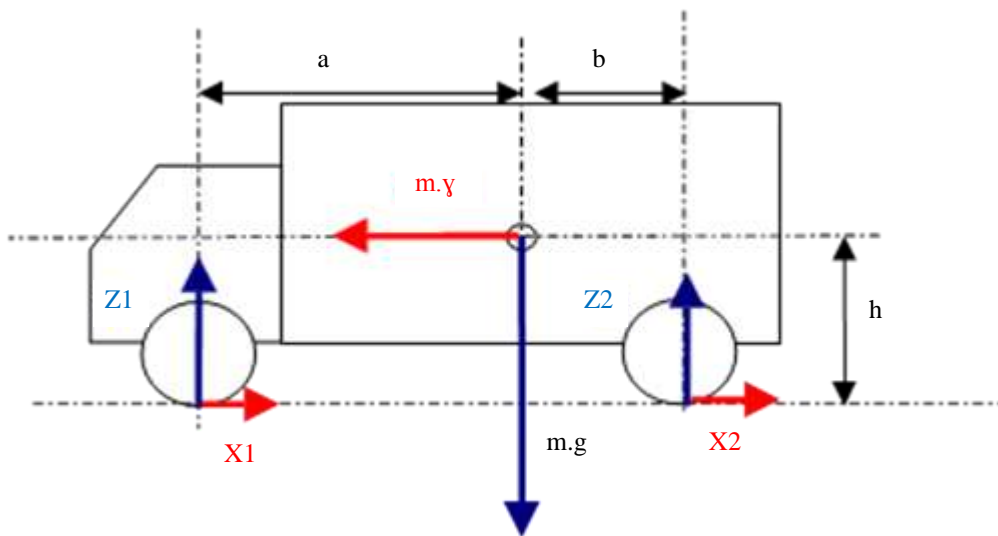

2.2.2.8. Wet grip performance comparison between a candidate tyre and a reference tyre using a control tyre

When the candidate tyre size is significantly different from the reference tyre, a direct comparison on the same vehicle may be not possible. This approach uses an intermediate tyre, hereinafter called the control tyre.

2.2.2.8.1. The principle lies upon the use of a control tyre and 2 different vehicles for assessing a candidate tyre in comparison with a reference tyre.

One vehicle can fit the reference tyre and the control tyre, the other the control tyre and the candidate tyre. All conditions are in conformity with paragraphs 2.2.1.2. to 2.2.2.5. above.

2.2.2.8.2. The first assessment is a comparison between the control tyre and the reference tyre. The result (Wet Grip Index 1) is the relative efficiency of the control tyre compared to the reference tyre.

2.2.2.8.3. The second assessment is a comparison between the candidate tyre and the control tyre. The result (Wet Grip Index 2) is the relative efficiency of the candidate tyre compared to the control tyre.

The second assessment is done on the same track as the first one and within one week maximum. The wetted surface temperature shall be in the range of $\pm 5^{\circ}\text{C}$ of the temperature of the first assessment. The control tyre set (4 or 6 tyres) is physically the same set as the set used for the first assessment.

2.2.2.8.4. The wet grip index of the candidate tyre compared to the reference tyre is deduced by multiplying the relative efficiencies calculated above:

(Wet Grip Index 1 · Wet Grip Index 2)

Note: When the test expert decides to use an SRTT tyre as a control tyre (i.e. in the test procedure two SRTTs are compared directly instead of an SRTT with a control tyre) the result of the comparison between the SRTTs is called the "local shift factor".

It is permitted to use a previous SRTTs comparison.

The comparison results shall be checked periodically.

2.2.2.8.5. Selection of a set of tyres as a control tyre set

A "control tyre" set is a group of identical tyres made in the same factory during a one week period.

2.2.2.8.6. Reference and control tyres

Before the first assessment (control tyre / reference tyre), normal storage conditions can be used. It is necessary that all the tyres of a control tyre set have been stored in the same conditions.

2.2.2.8.7. Storage of control tyres

As soon as the control tyre set has been assessed in comparison with the reference tyre, specific storage conditions shall be applied for control tyres replacement.

2.2.2.8.8. Replacement of reference and control tyres

When irregular wear or damage results from tests, or when wear influences the test results, the use of the tyre shall be discontinued.

Annex 5 – Appendix

Test reports examples of wet grip index

Example 1: Test report of wet grip index using trailer method

Test report number:

Test date:

Type of road surface:

Texture depth (mm):

μ peak (SRTT14 E1136) :

or BPN:

Speed (km/h):

Water depth (mm):

| No. | | 1 | 2 | 3 | 4 | 5 | 6 | 7 | 8 | 9 | 10 |
|---|---|---|---|---|---|---|---|---|---|---|----|
| Size | | | | | | | | | | | |
| Service description | | | | | | | | | | | |
| Tyre identification | | | | | | | | | | | |
| Rim | | | | | | | | | | | |
| Pattern | | | | | | | | | | | |
| Load (N) | | | | | | | | | | | |
| Pressure (kPa) | | | | | | | | | | | |
| μ peak | 1 | | | | | | | | | | |
| | 2 | | | | | | | | | | |
| | 3 | | | | | | | | | | |
| | 4 | | | | | | | | | | |
| | 5 | | | | | | | | | | |
| | 6 | | | | | | | | | | |
| | 7 | | | | | | | | | | |
| | 8 | | | | | | | | | | |
| Average | | | | | | | | | | | |
| Standard deviation σ | | | | | | | | | | | |
| $(\sigma/\text{average}) \leq 5$ per cent | | | | | | | | | | | |
| Ra, Adjusted | | | | | | | | | | | |
| Wet grip index | | | | | | | | | | | |
| Surface temp. (°C) | | | | | | | | | | | |
| Ambient temp. (°C) | | | | | | | | | | | |
| Remarks | | | | | | | | | | | |

Example 2: Test report of wet grip index using passenger car method

| | | |
|---------------------|----------------|-----------------------|
| Driver: | Test date: | |
| Track: | Passenger car: | Initial speed (km/h): |
| Texture depth (mm): | Brand: | Final speed (km/h): |
| BPN: | Model: | |
| Water depth (mm): | Type: | |

| No. | 1 | 2 | 3 | 4 | 5 | |
|--|-----------------------------|---|-----------------------------|---|-----------------------------|---|
| Brand | Uniroyal | TYRE B | TYRE C | TYRE D | Uniroyal | |
| Pattern | ASTM F 2493 SRTT16 | PATTERN B | PATTERN C | PATTERN D | ASTM F 2493 SRTT16 | |
| Size | P225/60R16 | SIZE B | SIZE C | SIZE D | P225/60R16 | |
| Service description | 97S | LI/SS | LI/SS | LI/SS | 97S | |
| Tyre identification | XXXXXXXXX | YYYYYYYYY | ZZZZZZZ | NNNNNNNNN | XXXXXXXXX | |
| Rim | | | | | | |
| Front axle pressure (kPa) | | | | | | |
| Rear axle pressure (kPa) | | | | | | |
| Front axle load (kg) | | | | | | |
| Rear axle load (kg) | | | | | | |
| Wet surface temp (°C) | | | | | | |
| Ambient temp (°C) | | | | | | |
| | <i>Braking distance (m)</i> | <i>Average deceleration (m/s²)</i> | <i>Braking distance (m)</i> | <i>Average deceleration (m/s²)</i> | <i>Braking distance (m)</i> | <i>Average deceleration (m/s²)</i> |
| Measurement | 1 | | | | | |
| | 2 | | | | | |
| | 3 | | | | | |
| | 4 | | | | | |
| | 5 | | | | | |
| | 6 | | | | | |
| | 7 | | | | | |
| | 8 | | | | | |
| | 9 | | | | | |
| | 10 | | | | | |
| Average AD (m/s ²) | | | | | | |
| Standard deviation (m/s ²) | | | | | | |
| Validation of results Coeff. of variation (per cent) < 3 per cent | | | | | | |
| Adjusted average AD of ref. tyre: R _a (m/s ²) | | | | | | |
| BFC(R) reference tyre (SRTT16) | | | | | | |
| BFC(T) candidate tyre | | | | | | |
| Wet grip index (%) | | | | | | |

Annex 6

Test procedure for measuring rolling resistance

1. Test methods

The alternative measurement methods listed below are given in this Regulation. The choice of an individual method is left to the tester. For each method, the test measurements shall be converted to a force acting at the tyre/drum interface. The measured parameters are:

- (a) In the force method: the reaction force measured or converted at the tyre spindle;¹
- (b) In the torque method: the torque input measured at the test drum;²
- (c) In the deceleration method: the measurement of deceleration of the test drum and tyre assembly;²
- (d) In the power method: the measurement of the power input to the test drum.²

2. Test equipment

2.1. Drum specifications

2.1.1. Diameter

The test dynamometer shall have a cylindrical flywheel (drum) with a diameter of at least 1.7 m.

The F_r and C_r values shall be expressed relative to a drum diameter of 2.0 m. If drum diameter different than 2.0 m is used, a correlation adjustment shall be made following the method in paragraph 6.3. of this annex.

2.1.2. Surface

The surface of the drum shall be smooth steel. Alternatively, in order to improve skim test reading accuracy, a textured surface may also be used, which should be kept clean.

The F_r and C_r values shall be expressed relative to the "smooth" drum surface. If a textured drum surface is used, see Appendix 1, paragraph 7.

2.1.3. Width

The width of the drum test surface shall exceed the width of the test tyre contact patch.

¹ This measured value also includes the bearing and aerodynamic losses of the wheel and tyre which are also to be considered for further data interpretation.

² The measured value in the torque, deceleration and power methods also includes the bearing and aerodynamic losses of the wheel, the tyre, and the drum which are also to be considered for further data interpretation.

- 2.2. Measuring rim (see Appendix 2)
The tyre shall be mounted on a steel or light alloy measuring rim, as follows:
- (a) For Class C1 tyres, the width of the rim shall be as defined in ISO 4000-1:2010,
 - (b) For Class C2 and C3 tyres, the width of the rim shall be as defined in ISO 4209 1:2001.
- In cases where the width is not defined in the above mentioned ISO Standards, the rim width as defined by one of the standards organizations as specified in Appendix 4 may be used.
- 2.3. Load, alignment, control and instrumentation accuracies
Measurement of these parameters shall be sufficiently accurate and precise to provide the required test data. The specific and respective values are shown in Appendix 1.
- 2.4. Thermal environment
- 2.4.1. Reference conditions
The reference ambient temperature, measured at a distance not less than 0.15 m and not more than 1 m from the tyre sidewall, shall be 25 °C.
- 2.4.2. Alternative conditions
If the test ambient temperature is different from the reference ambient temperature, the rolling resistance measurement shall be corrected to the reference ambient temperature in accordance with paragraph 6.2. of this annex.
- 2.4.3. Drum surface temperature.
Care should be taken to ensure that the temperature of the test drum surface is the same as the ambient temperature at the beginning of the test.
3. Test conditions
- 3.1. General
The test consists of a measurement of rolling resistance in which the tyre is inflated and the inflation pressure allowed to build up, i.e., "capped air".
- 3.2. Test speeds
The value shall be obtained at the appropriate drum speed specified in Table 1.

Table 1
Test Speeds (in km/h)

| <i>Tyre Class</i> | <i>C1</i> | <i>C2 and C3</i> | <i>C3</i> | |
|-------------------|-----------|------------------|--|-----------------------|
| Load index | All | LI ≤ 121 | LI > 121 | |
| Speed symbol | All | All | J 100 km/h and lower or tyres not marked with speed symbol | K 110 km/h and higher |
| Speed | 80 | 80 | 60 | 80 |

3.3. Test load

The standard test load shall be computed from the values shown in Table 2 and shall be kept within the tolerance specified in Appendix 1.

3.4. Test inflation pressure

The inflation pressure shall be in accordance with that shown in Table 2 and shall be capped with the accuracy specified in paragraph 4. of Appendix 1 to this annex.

Table 2
Test loads and inflation pressures

| Tyre Class | C1 ^(a) | | C2, C3 |
|-----------------------------------|-------------------|--------------------------|--|
| | Standard load | Reinforced or extra load | |
| Load - % of maximum load capacity | 80 | 80 | 85 ^(b) (% of single load) |
| Inflation pressure kPa | 210 | 250 | Corresponding to maximum load capacity for single application ^(c) |

Note: The inflation pressure shall be capped with the accuracy specified in paragraph 4. of Appendix 1 to this annex.

- (a) For those passenger car tyres belonging to categories which are not shown in ISO 4000-1:2010, the inflation pressure shall be the inflation pressure recommended by the tyre manufacturer, corresponding to the maximum tyre load capacity, reduced by 30 kPa.
- (b) As a percentage of single load, or 85 per cent of maximum load capacity for single application specified in applicable tyre standards manuals if not marked on tyre.
- (c) Inflation pressure marked on sidewall, or if not marked on sidewall, as specified in applicable tyre standards manuals corresponding to maximum load capacity for single application.

3.5. Duration and speed.

When the deceleration method is selected, the following requirements apply:

- (a) The deceleration j shall be determined in differential $d\omega/dt$ or discrete $\Delta\omega/\Delta t$ form, where ω is angular velocity, t – time;
If the differential form $d\omega/dt$ is used, then the recommendations of Appendix 5 to this annex are to be applied.
- (b) For duration Δt , the time increments shall not exceed 0.5 s;
- (c) Any variation of the test drum speed shall not exceed 1 km/h within one time increment.

4. Test procedure

4.1. General

The test procedure steps described below shall be followed in the sequence given.

- 4.2. Thermal conditioning
The inflated tyre shall be placed in the thermal environment of the test location for a minimum of:
- (a) 3 hours for Class C1 tyres;
 - (b) 6 hours for Class C2 and C3 tyres.
- 4.3. Pressure adjustment
After thermal conditioning, the inflation pressure shall be adjusted to the test pressure, and verified 10 minutes after the adjustment is made.
- 4.4. Warm-up
The warm-up durations shall be as specified in Table 3.

Table 3
Warm up durations

| Tyre Class | C1 | C2 and C3 <i>LI ≤ 121</i> | C3 | |
|----------------------|---------|------------------------------|---------------------|------------------|
| | | | <i>LI < 22.5</i> | <i>LI ≥ 22.5</i> |
| Nominal Rim Diameter | All | All | < 22.5 | ≥ 22.5 |
| Warm up duration | 30 min. | 50 min. | 150 min. | 180 min. |

- 4.5. Measurement and recording
The following shall be measured and recorded (see Figure 1):
- (a) Test speed U_n ;
 - (b) Load on the tyre normal to the drum surface L_m ;
 - (c) The initial test inflation pressure as defined in paragraph 3.3. above;
 - (d) The coefficient of rolling resistance measured C_r , and its corrected value C_{rc} , at 25 °C and for a drum diameter of 2 m;
 - (e) The distance from the tyre axis to the drum outer surface under steady state r_L ;
 - (f) Ambient temperature t_{amb} ;
 - (g) Test drum radius R;
 - (h) Test method chosen;
 - (i) Test rim (size and material);
 - (j) Tyre size, manufacturer, type, identity number (if one exists), speed symbol, load index, DOT number (Department of Transportation).

Figure 1

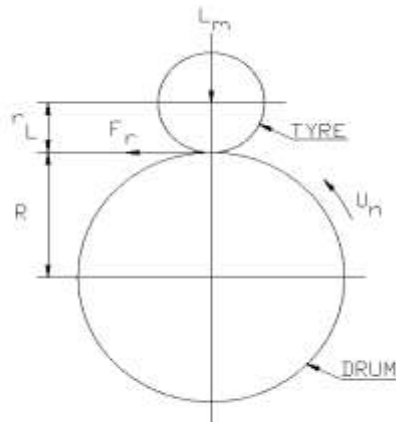

All the mechanical quantities (forces, torques) will be orientated in accordance with the axis systems specified in ISO 8855:1991.

The directional tyres shall be run in their specified rotation sense.

4.6. Measurement of parasitic losses

The parasitic losses shall be determined by one of the following procedures given in paragraph 4.6.1. or 4.6.2. below.

4.6.1. Skim test reading

Skim test reading follows the procedure below:

- (a) Reduce the load to maintain the tyre at the test speed without slippage.³

The load values should be as follows:

- (i) Class C1 tyres: recommended value of 100 N; not to exceed 200 N;
 - (ii) Class C2 tyres: recommended value of 150 N; not to exceed 200 N for machines designed for Class C1 tyre measurement or 500 N for machine designed for Class C2 and C3 tyres;
 - (iii) Class C3 tyres: recommended value of 400 N; not to exceed 500 N.
- (b) Record the spindle force F_t , input torque T_i , or the power, whichever applies;³
- (c) Record the load on the tyre normal to the drum surface L_m .³

³ With the exception of the force method, the measured value includes the bearing and aerodynamic losses of the wheel, the tyre, and the drum losses which also need to be considered. It is known that the spindle and drum bearing frictions depend on the applied load. Consequently, it is different for the loaded system measurement and the skim test reading. However, for practical reasons, this difference can be disregarded.

4.6.2. Deceleration method

The deceleration method follows the procedure below:

- (a) Remove the tyre from the test surface;
- (b) Record the deceleration of the test drum $\Delta\omega_{D0}/\Delta t$ and that of the unloaded tyre $\Delta\omega_{T0}/\Delta t$ or record the deceleration of the test drum j_{D0} and that of the unloaded tyre j_{T0} in exact or approximate form in accordance with paragraph 3.5. above.

4.7. Allowance for machines exceeding σ_m criterion

The steps described in paragraphs 4.3. to 4.5. above shall be carried out once only, if the measurement standard deviation determined in accordance with paragraph 6.5. below is:

- (a) Not greater than 0.075 N/kN for Class C1 and C2 tyres;
- (b) Not greater than 0.06 N/kN for Class C3 tyres.

If the measurement standard deviation exceeds this criterion, the measurement process will be repeated n times as described in paragraph 6.5. below. The rolling resistance value reported shall be the average of the n measurements.

5. Data interpretation

5.1. Determination of parasitic losses

5.1.1. General

The laboratory shall perform the measurements described in paragraph 4.6.1. above for the force, torque and power methods or those described in paragraph 4.6.2. above for the deceleration method, in order to determine precisely in the test conditions (load, speed, temperature) the tyre spindle friction, the tyre and wheel aerodynamic losses, the drum (and as appropriate, engine and/or clutch) bearing friction, and the drum aerodynamic losses.

The parasitic losses related to the tyre/drum interface F_{pl} expressed in newton shall be calculated from the force F_t torque, power or the deceleration, as shown in paragraphs 5.1.2. to 5.1.5. below.

5.1.2. Force method at tyre spindle

Calculate: $F_{pl} = F_t(1 + r_L/R)$

Where:

- F_t is the tyre spindle force in newton (see paragraph 4.6.1. above),
- r_L is the distance from the tyre axis to the drum outer surface under steady state conditions, in meter,
- R is the test drum radius, in meter.

5.1.3. Torque method at drum axis

Calculate: $F_{pl} = T_t/R$

Where:

T_t is the input torque in newton meter, as determined in paragraph 4.6.1,

R is the test drum radius, in meter.

5.1.4. Power method at drum axis

Calculate: $F_{pl} = \frac{3,6V \times A}{U_n}$

Where:

V is the electrical potential applied to the machine drive, in volt,

A is the electric current drawn by the machine drive, in ampere,

U_n is the test drum speed, in kilometer per hour.

5.1.5. Deceleration method

Calculate the parasitic losses F_{pl} , in newton.

$$F_{pl} = \frac{I_D}{R} \left(\frac{\Delta\omega_{D0}}{\Delta t_0} \right) + \frac{I_T}{R_r} \left(\frac{\Delta\omega_{T0}}{\Delta_0} \right)$$

Where:

I_D is the test drum inertia in rotation, in kilogram meter squared,

R is the test drum surface radius, in meter,

ω_{D0} is the test drum angular speed, without tyre, in radians per second,

Δt_0 is the time increment chosen for the measurement of the parasitic losses without tyre, in second,

I_T is the spindle, tyre and wheel inertia in rotation, in kilogram meter squared,

R_r is the tyre rolling radius, in meter,

ω_{T0} is the tyre angular speed, unloaded tyre, in radian per second.

or

$$F_{pl} = \frac{I_D}{R} j_{D0} + \frac{I_T}{R_r} j_{T0}$$

Where:

I_D is the test drum inertia in rotation, in kilogram meter squared,

R is the test drum surface radius, in meter,

j_{D0} is the deceleration of the test drum, without tyre, in radians per second squared,

I_T is the spindle, tyre and wheel inertia in rotation, in kilogram meter squared,
 R_r is the tyre rolling radius, in meter,
 j_{T0} is the deceleration of unloaded tyre, in radians per second squared.

5.2. Rolling resistance calculation

5.2.1. General

The rolling resistance F_r , expressed in newton, is calculated using the values obtained by testing the tyre to the conditions specified in this international standard and by subtracting the appropriate parasitic losses F_{pl} , obtained according to paragraph 5.1. above.

5.2.2. Force method at tyre spindle

The rolling resistance F_r , in newton, is calculated using the equation

$$F_r = F_t[1 + (r_L/R)] - F_{pl}$$

Where:

F_t is the tyre spindle force in newton,
 F_{pl} represents the parasitic losses as calculated in paragraph 5.1.2. above,
 r_L is the distance from the tyre axis to the drum outer surface under steady-state conditions, in meter,
 R is the test drum radius, in meter.

5.2.3. Torque method at drum axis

The rolling resistance F_r , in newton, is calculated with the equation

$$F_r = \frac{T_t}{R} - F_{pl}$$

Where:

T_t is the input torque, in newton meter,
 F_{pl} represents the parasitic losses as calculated in paragraph 5.1.3. above,
 R is the test drum radius, in meter.

5.2.4. Power method at drum axis

The rolling resistance F_r , in newton, is calculated with the equation:

$$F_r = \frac{3.6V \times A}{U_n} - F_{pl}$$

Where:

V = is the electrical potential applied to the machine drive, in volt,
 A = is the electric current drawn by the machine drive, in ampere,

- U_n = is the test drum speed, in kilometer per hour,
 F_{pl} = represents the parasitic losses as calculated in paragraph 5.1.4. above.

5.2.5. Deceleration method

The rolling resistance Fr , in newton, is calculated using the equation:

$$Fr = \frac{I_D}{R} \left(\frac{\Delta\omega_V}{\Delta t_V} \right) + \frac{R \times I_T}{R_r^2} \left(\frac{\Delta\omega_V}{\Delta t_V} \right) - F_{pl}$$

Where:

- I_D is the test drum inertia in rotation, in kilogram meter squared,
 R is the test drum surface radius, in meter,
 F_{pl} represents the parasitic losses as calculated in paragraph 5.1.5. above,
 Δt_V is the time increment chosen for measurement, in second,
 $\Delta\omega_V$ is the test drum angular speed increment, without tyre, in radian per second,
 I_T is the spindle, tyre and wheel inertia in rotation, in kilogram meter squared,
 R_r is the tyre rolling radius, in meter,
 F_r is the rolling resistance, in newton.

or

$$Fr = \frac{I_D}{R} j_V + \frac{R \times I_T}{R_r^2} j_V - F_{pl}$$

Where:

- I_D is the test drum inertia in rotation, in kilogram meter squared,
 R is the test drum surface radius, in meter,
 F_{pl} represents the parasitic losses as calculated in paragraph 5.1.5. above,
 j_V is the deceleration of the test drum, in radians per second squared,
 I_T is the spindle, tyre and wheel inertia in rotation, in kilogram meter squared,
 R_r is the tyre rolling radius, in meter,
 F_r is the rolling resistance, in newton.

6. Data analysis

6.1. Rolling resistance coefficient

The rolling resistance coefficient C_r is calculated by dividing the rolling resistance by the load on the tyre:

$$C_r = \frac{F_r}{L_m}$$

Where:

F_r is the rolling resistance, in newton,

L_m is the test load, in kN.

6.2. Temperature correction

If measurements at temperatures other than 25 °C are unavoidable (only temperatures not less than 20 °C or more than 30 °C are acceptable), then a correction for temperature shall be made using the following equation, with:

F_{r25} is the rolling resistance at 25 °C, in Newton:

$$F_{r25} = F_r [1 + K(t_{amb} - 25)]$$

Where:

F_r is the rolling resistance, in Newton,

t_{amb} is the ambient temperature, in degree Celsius,

K is equal to:

0.008 for Class C1 tyres

0.010 for Class C2 and C3 tyres with a load index equal or lower than 121

0.006 for Class C3 tyres with a load index greater than 121

6.3. Drum diameter correction

Test results obtained from different drum diameters shall be compared by using the following theoretical formula:

$$F_{r02} \cong KF_{r01}$$

With:

$$K = \sqrt{\frac{(R_1/R_2)(R_2 + r_T)}{(R_1 + r_T)}}$$

Where:

R_1 is the radius of drum 1, in meter,

R_2 is the radius of drum 2, in meter,

r_T is one-half of the nominal design tyre diameter, in meter,

F_{r01} is the rolling resistance value measured on drum 1, in newton,

F_{r02} is the rolling resistance value measured on drum 2, in newton.

6.4. Measurement result

Where n measurements are greater than 1, if required by paragraph 4.6. above, the measurement result shall be the average of the C_r values obtained for the n measurements, after the corrections described in paragraphs 6.2. and 6.3. above have been made.

6.5. The laboratory shall ensure that, based on a minimum of three measurements, the machine maintains the following values of σ_m , as measured on a single tyre:

$\sigma_m \leq 0.075$ N/kN for tyres of Classes C1 and C2

$\sigma_m \leq 0.06$ N/kN for tyres of Class C3

If the above requirement for σ_m is not met, the following formula shall be applied to determine the minimum number of measurements n (rounded to the immediate superior integer value) that are required by the machine to qualify for conformance with this Regulation.

$$n = (\sigma_m / x)^2$$

Where:

$x = 0.075$ N/kN for tyres of Classes C1 and C2

$x = 0.06$ N/kN for tyres of Class C3

If a tyre needs to be measured several times, the tyre/wheel assembly shall be removed from the machine between the successive measurements.

If the removal/refitting operation duration is less than 10 minutes, the warm-up durations indicated in paragraph 4.3. above may be reduced to:

- (a) 10 minutes for tyres of Class C1;
- (b) 20 minutes for tyres of Class C2;
- (c) 30 minutes for tyres of Class C3.

6.6. Monitoring of the laboratory control tyre shall be carried out at intervals no greater than one month. Monitoring shall include a minimum of 3 separate measurements taken during this one month period. The average of the 3 measurements taken during a given one-month period shall be evaluated for drift from one monthly evaluation to another.

Annex 6 - Appendix 1

Test equipment tolerances

1. Purpose
The limits specified in this annex are necessary in order to achieve suitable levels of repeatable test results, which can also be correlated among various test laboratories. These tolerances are not meant to represent a complete set of engineering specifications for test equipment; rather, they should serve as guidelines for achieving reliable test results.
2. Test rims
 - 2.1. Width
For passenger car tyre rims (C1 tyres), the test rim width shall be the same as the measuring rim determined in ISO 4000-1: 2010, clause 6.2.2.
For truck and bus tyres (C2 and C3), the rim width shall be the same as the measuring rim determined in ISO 4209-1:2001, clause 5.1.3.
In cases where the width is not defined in the above mentioned ISO Standards, the rim width as defined by one of the standards organizations as specified in Appendix 4 to Annex 6 may be used.
 - 2.2. Run-out
Run-out shall meet the following criteria:
 - (a) Maximum radial run-out: 0.5 mm;
 - (b) Maximum lateral run-out: 0.5 mm.
3. Drum / tyre alignment
General:
Angle deviations are critical to the test results.
 - 3.1. Load application
The direction of tyre loading application shall be kept normal to the test surface and shall pass through the wheel centre within
 - (a) 1 mrad for the force and deceleration methods;
 - (b) 5 mrad for the torque and power methods.
 - 3.2. Tyre alignment
 - 3.2.1. Camber angle
The plane of the wheel shall be perpendicular to the test surface within 2 mrad for all methods.
 - 3.2.2. Slip angle
The plane of the tyre shall be parallel to the direction of the test surface motion within 1 mrad for all methods.

4. Control accuracy

Test conditions shall be maintained at their specified values, independent of perturbations induced by the tyre and rim non-uniformity, such that the overall variability of the rolling resistance measurement is minimized. In order to meet this requirement, the average value of measurements taken during the rolling resistance data collection period shall be within the accuracies stated as follows:

- (a) Tyre loading:
 - (i) For $LI \leq 121$ ± 20 N or ± 0.5 per cent, whichever is greater;
 - (ii) For $LI > 121$ ± 45 N or ± 0.5 per cent whichever is greater;
- (b) Cold inflation pressure: ± 3 kPa;
- (c) Surface speed:
 - (i) ± 0.2 km/h for the power, torque and deceleration methods;
 - (ii) ± 0.5 km/h for the force method;
- (d) Time:
 - (i) ± 0.02 s for the time increments specified in Annex 6, paragraph 3.5.(b) for the data acquisition in the deceleration method in $\Delta\omega/\Delta t$ form;
 - (ii) ± 0.2 per cent for the time increments specified in Annex 6, paragraph 3.5.(a) for the data acquisition in the deceleration method in $d\omega/dt$ form;
 - (iii) ± 5 per cent for the other time durations specified in Annex 6.

5. Instrumentation accuracy

The instrumentation used for readout and recording of test data shall be accurate within the tolerances stated below:

| Parameter | Load Index ≤ 121 | Load Index > 121 |
|--------------------|---|----------------------------------|
| Tyre load | ±10 N or ±0.5 % ^(a) | ±30 N or ±0.5 % ^(a) |
| Inflation pressure | ±1 kPa | ±1.5 kPa |
| Spindle force | ±0.5 N or ±0.5 % ^(a) | ±1.0 N or ±0.5 % ^(a) |
| Torque input | ±0.5 Nm or ±0.5 % ^(a) | ±1.0 Nm or ±0.5 % ^(a) |
| Distance | ±1 mm | ±1 mm |
| Electrical power | ±10 W | ±20 W |
| Temperature | ±0.2 °C | |
| Surface speed | ±0.1 km/h | |
| Time | ±0.01 s - ±0.1 % - ±10 s ^(b) | |
| Angular velocity | ±0.1 % | |

^(a) Whichever is greater.

^(b) ±0.01 s for the time increments specified in Annex 6, paragraph 3.5.(b) for the data acquisition in the deceleration method in $\Delta\omega/\Delta t$ form
±0.1 per cent for the time increments specified in Annex 6, paragraph 3.5.(a) for the data acquisition in the deceleration method in $d\omega/dt$ form
± 10 sec for the other time durations specified in Annex 6.

6. Compensation for load/spindle force interaction and load misalignment for the force method only

Compensation of both load/spindle force interaction ("cross talk") and load misalignment may be achieved either by recording the spindle force for both forward and reverse tyre rotation or by dynamic machine calibration. If spindle force is recorded for forward and reverse directions (at each test condition), compensation is achieved by subtracting the "reverse" value from the "forward" value and dividing the result by two. If dynamic machine calibration is intended, the compensation terms may be easily incorporated in the data reduction.

In cases where reverse tyre rotation immediately follows the completion of the forward tyre rotation, a warm-up time for reverse tyre rotation shall be at least 10 minutes for Class C1 tyres and 30 minutes for all other tyre types.

7. Test surface roughness

The roughness, measured laterally, of the smooth steel drum surface shall have a maximum centreline average height value of 6.3 µm.

Note: In cases where a textured drum surface is used instead of a smooth steel surface, this fact is noted in the test report. The surface texture shall then be 180 µm deep (80 grit) and the laboratory is responsible for maintaining the surface roughness characteristics. No specific correction factor is recommended for cases where a textured drum surface is used.

Annex 6 - Appendix 2

Measuring rim width

1. Class C1 tyres

The measuring rim width R_m is equal to the product of the nominal section width S_N and the coefficient K_2 :

$$R_m = K_2 \times S_N$$

rounded to the nearest standardized rim, where K_2 is the rim/section width ratio coefficient. For tyres mounted on 5° drop-centre rims with a nominal diameter expressed by a two-figure code:

$$K_2 = 0.7 \text{ for nominal aspect ratios 95 to 75}$$

$$K_2 = 0.75 \text{ for nominal aspect ratios 70 to 60}$$

$$K_2 = 0.8 \text{ for nominal aspect ratios 55 and 50}$$

$$K_2 = 0.85 \text{ for nominal aspect ratio 45}$$

$$K_2 = 0.9 \text{ for nominal aspect ratios 40 to 30}$$

$$K_2 = 0.92 \text{ for nominal aspect ratios 20 and 25}$$

2. Class C2 and C3 tyres

The measuring rim width R_m is equal to the product of the nominal section width S_N , and the coefficient K_4 :

$$R_m = K_4 \times S_N \text{ rounded to the nearest standardized rim width.}$$

Table 1
Coefficients for determining measuring rim width

| <i>Tyre structure code</i> | <i>Type of rim</i> | <i>Nominal aspect ratio H/S</i> | <i>Measuring rim/ section ratio K_4</i> |
|----------------------------|--------------------|---------------------------------|--|
| B, D, R | 5° tapered | 100 to 75 | 0.70 |
| | | 70 and 65 | 0.75 |
| | | 60 | 0.75 |
| | | 55 | 0.80 |
| | | 50 | 0.80 |
| | | 45 | 0.85 |
| | | 40 | 0.90 |
| | | 15° tapered (drop-centre) | 90 to 65 |
| | 60 | | 0.80 |
| | 55 | | 0.80 |
| | 50 | | 0.80 |
| | 45 | | 0.85 |
| | 40 | | 0.85 |

Note: Other factors may be established for new tyre concepts (structures).

Annex 6 - Appendix 3

Test report and test data (Rolling resistance)

Part 1: Report

1. Type Approval Authority or Technical Service:
2. Name and address of applicant:
3. Test report No.:
4. Manufacturer and brand name or trade description:
5. Tyre class (C1, C2 or C3):
6. Category of use:
7. Rolling resistance coefficient
(temperature and drum diameter corrected):
8. Comments (if any):
9. Date:
10. Signature:

Part 2: Test data

1. Date of test:
2. Test machine identification and drum diameter/surface:
3. Test tyre details:
- 3.1. Tyre size designation and service description:
- 3.2. Tyre brand and trade description:
- 3.3. Reference inflation pressure:kPa
4. Test data:
- 4.1. Measurement method:
- 4.2. Test speed: km/h
- 4.3. Load: N
- 4.4. Test inflation pressure, initial:kPa
- 4.5. Distance from the tyre axis to the drum outer surface under steady state
conditions, r_L : m
- 4.6. Test rim width and material:
- 4.7. Ambient temperature: °C
- 4.8. Skim test load (except deceleration method): N
5. Rolling resistance coefficient:
- 5.1. Initial value (or average in the case of more than 1):N/kN
- 5.2. Temperature corrected:N/kN
- 5.3. Temperature and drum diameter corrected:N/kN

Annex 6 – Appendix 4

Tyre standards organizations

1. The Tire and Rim Association, Inc. (TRA)
2. The European Tyre and Rim Technical Organisation (ETRTO)
3. The Japan Automobile Tyre Manufacturers' Association (JATMA)
4. The Tyre and Rim Association of Australia (TRAA)
5. South Africa Bureau of Standards (SABS)
6. China Association for Standardization (CAS)
7. Indian Tyre Technical Advisory Committee (ITTAC)
8. International Standards Organisation (ISO)

Annex 6 – Appendix 5

Deceleration method: Measurements and data processing for deceleration value obtaining in differential form $d\omega/dt$.

1. Record dependency "distance-time" of rotating body decelerated from peripheral with a speed range such as 82 to 78 km/h or 62 to 58 km/h dependent on tyre class (Annex 6, paragraph 3.2., Table 1) in a discrete form (Figure 1) for a rotating body:

$$z = f(t_z)$$

Where:

z is a number of body revolutions during deceleration;

t_z is end time of revolution number z in seconds recorded with 6 digits after zero.

Figure 1

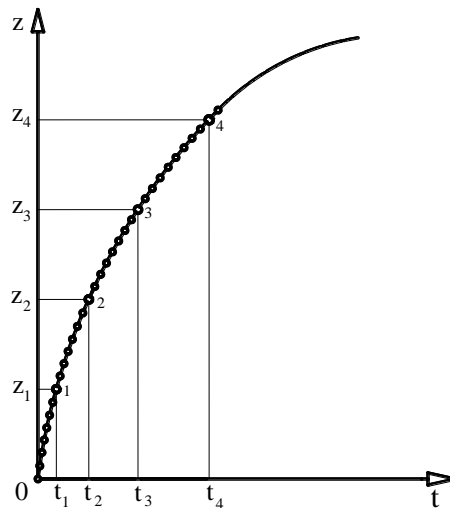

Note 1: The lower speed of the recording range may be reduced down to 60 km/h when test speed is 80 km/h and 40 km/h when the test speed is 60 km/h.

2. Approximate recorded dependency by continuous, monotonic, differentiable function:
 - 2.1. Choose the value nearest to the maximum of z dividable by 4 and divide it into 4 equal parts with bounds: $0, z_1(t_1), z_2(t_2), z_3(t_3), z_4(t_4)$.
 - 2.2. Work out the system for 4 equations each of the form:

$$z_m = A \ln \frac{\cos B(T_\Sigma - t_m)}{\cos B T_\Sigma}$$

Where unknowns:

A is a dimensionless constant,

B is a constant in revolutions per second,

T_{Σ} is a constant in seconds,

m is the number of bounds shown in figure 1.

Insert in these 4 equations the coordinates of 4-th bound above.

- 2.3. Take constants A, B and T_{Σ} as the solution of the equation system of paragraph 2.2. above using iteration process and approximate measured data by formulae:

$$z(t) = A \ln \frac{\cos B(T_{\Sigma} - t)}{\cos BT_{\Sigma}}$$

Where:

$z(t)$ is the current continuous angular distance in number of revolutions (not only integer values);

t is time in seconds.

Note 2: Other approximating functions $z = f(t_z)$ may be used if their adequacy is proven.

3. Calculate the deceleration j in revolutions per second squared (s^{-2}) by the formula:

$$j = AB^2 + \frac{\omega^2}{A}$$

Where:

ω is the angular speed in revolutions per second (s^{-1}).

For the case $U_n = 80$ km/h; $\omega = 22.222/R_r$ (or R).

For the case $U_n = 60$ km/h; $\omega = 16.666/R_r$ (or R).

4. Estimate the quality of approximation of measured data and its accuracy by parameters:

- 4.1. Standard deviation in percentages:

$$\sigma = \sqrt{\frac{1}{n-1} \sum_1^n \left[1 - \frac{z(t)}{z} \right]^2} \times 100\%$$

- 4.2. Coefficient of determination

$$R^2 = 1 - \frac{\sum_1^n [z - z(t)]^2}{\sum_1^n [z - \bar{z}]^2}$$

Where:

$$\bar{z} = \frac{1}{n} \sum_{z=1}^n z = \frac{1}{n} (1 + 2 + \dots + n) = \frac{1+n}{2}$$

Note 3: The above calculations for this variant of the deceleration method for tyre rolling resistance measurement can be executed by the computer program "Deceleration Calculator" downloadable from the WP.29 website¹ as well as any software which allows the calculation of nonlinear regression.

¹ http://www.unece.org/trans/main/wp29/wp29wgs/wp29gen/deceleration_calculator.html.

Annex 7

Procedures for snow performance testing relative to snow tyre for use in severe snow conditions

1. Specific definitions for snow test when different from existing ones
 - 1.1. "Test run" means a single pass of a loaded tyre over a given test surface.
 - 1.2. "Braking test" means a series of a specified number of ABS-braking test runs of the same tyre repeated within a short time frame.
 - 1.3. "Traction test" means a series of a specified number of spin-traction test runs according to ASTM standard F1805-06 of the same tyre repeated within a short time frame.
 - 1.4. "Acceleration test" means a series of specified number of traction controlled acceleration test runs of the same tyre repeated within a short timeframe.
2. Spin traction method for Class C1 and C2 tyres (traction force test per paragraph 6.4. (b) of this Regulation)

The test procedure of ASTM standard F1805-06 shall be used to assess snow performance through spin traction values on medium packed snow (The snow compaction index measured with a CTI penetrometer¹ shall be between 70 and 80).

 - 2.1. The test course surface shall be composed of a medium packed snow surface, as characterized in table A2.1 of ASTM standard F1805-06.
 - 2.2. The tyre load for testing shall be as per option 2 in paragraph 11.9.2. of ASTM standard F1805-06.
3. Braking on snow method for Class C1 and C2 tyres
 - 3.1. General conditions
 - 3.1.1. Test course

The braking tests shall be done on a flat test surface of sufficient length and width, with a maximum 2 per cent gradient, covered with packed snow.

The snow surface shall be composed of a hard packed snow base at least 3 cm thick and a surface layer of medium packed and prepared snow about 2 cm thick.

The air temperature, measured about one meter above the ground, shall be between -2 °C and -15 °C; the snow temperature, measured at a depth of about one centimeter, shall be between -4 °C and -15 °C.

It is recommended to avoid direct sunlight, large variations of sunlight or humidity, as well as wind.

¹ See appendix of ASTM standard F1805-06 for details.

The snow compaction index measured with a CTI penetrometer¹ shall be between 75 and 85.

3.1.2. Vehicle

The test shall be conducted with a standard production vehicle in good running order and equipped with an ABS system.

The vehicle used shall be such that the loads on each wheel are appropriate to the tyres being tested. Several different tyre sizes can be tested on the same vehicle.

3.1.3. Tyres

The tyres should be "broken-in" prior to testing to remove spew, compound nodules or flashes resulting from the moulding process. The tyre surface in contact with snow shall be cleaned before performing a test.

Tyres shall be conditioned at the outdoor ambient temperature at least two hours before their mounting for tests. Tyre pressures shall then be adjusted to the values specified for the test.

In case a vehicle cannot accommodate both the reference and candidate tyres, a third tyre ("control" tyre) may be used as an intermediate. First test control vs. reference on another vehicle, then test candidate vs. control on the vehicle.

3.1.4. Load and pressure

3.1.4.1. For C1 tyres, the vehicle load shall be such that the resulting loads on the tyres are between 60 per cent and 90 per cent of the load corresponding to the tyre load index.

The cold inflation pressure shall be 240 kPa.

3.1.4.2. For C2 tyres, the vehicle load shall be such that the resulting loads on the tyres are between 60 per cent and 100 per cent of the load corresponding to the tyre load index.

The static tyre load on the same axle should not differ by more than 10 per cent.

The inflation pressure is calculated to run at constant deflection:

For a vertical load higher or equal to 75 per cent of the load capacity of the tyre, a constant deflection is applied, hence the test inflation pressure "Pt" shall be calculated as follows:

$$P_t = P_r \left(\frac{Q_t}{Q_r} \right)^{1.25}$$

Q_r is the maximum load associated to the load capacity index of the tyre written on the sidewall

P_r is the reference pressure corresponding to the maximum load capacity Q_r

Q_t is the static test load of the tyre

For a vertical load lower than 75 per cent of the load capacity of the tyre, a constant inflation pressure is applied, hence the test inflation pressure P_t shall be calculated as follows:

$$P_t = P_r (0.75)^{1.25} = (0.7)P_r$$

P_r is the reference pressure corresponding to the maximum load capacity Q_r

Check the tyre pressure just prior to testing at ambient temperature.

3.1.5. Instrumentation

The vehicle shall be fitted with calibrated sensors suitable for measurements in winter. There shall be a data acquisition system to store measurements.

The accuracy of measurement sensors and systems shall be such that the relative uncertainty of the measured or computed mean fully developed decelerations is less than 1 per cent.

3.2. Testing sequences

3.2.1. For every candidate tyre and the standard reference tyre, ABS-braking test runs shall be repeated a minimum of 6 times.

The zones where ABS-braking is fully applied shall not overlap.

When a new set of tyres is tested, the runs are performed after shifting aside the vehicle trajectory in order not to brake on the tracks of the previous tyre.

When it is no longer possible not to overlap full ABS-braking zones, the test course shall be re-groomed.

Required sequence:

6 repeats SRTT, then shift aside to test next tyre on fresh surface

6 repeats Candidate 1, then shift aside

6 repeats Candidate 2, then shift aside

6 repeats SRTT, then shift aside

3.2.2. Order of testing:

If only one candidate tyre is to be evaluated, the order of testing shall be:

R1 - T - R2

Where:

R1 is the initial test of the SRTT, R2 is the repeat test of the SRTT and T is the test of the candidate tyre to be evaluated.

A maximum of two candidate tyres may be tested before repeating the SRTT test, for example:

R1 - T1 - T2 - R2.

3.2.3. The comparative tests of SRTT and candidate tyres shall be repeated on two different days.

- 3.3. Test procedure
- 3.3.1. Drive the vehicle at a speed not lower than 28 km/h.
- 3.3.2. When the measuring zone has been reached, the vehicle gear is set into neutral, the brake pedal is depressed sharply by a constant force sufficient to cause operation of the ABS on all wheels of the vehicle and to result in stable deceleration of the vehicle and held down until the speed is lower than 8 km/h.
- 3.3.3. The mean fully developed deceleration between 25 km/h and 10 km/h shall be computed from time, distance, speed, or acceleration measurements.
- 3.4. Data evaluation and presentation of results
- 3.4.1. Parameters to be reported
- 3.4.1.1. For each tyre and each braking test, the mean and standard deviation of the mfdd shall be computed and reported.
- The coefficient of variation CV of a tyre braking test shall be computed as:
- $$CV(\text{tyre}) = \frac{\text{Std.dev}(\text{tyre})}{\text{Mean}(\text{tyre})}$$
- 3.4.1.2. Weighted averages of two successive tests of the SRTT shall be computed taking into account the number of candidate tyres in between:
- In the case of the order of testing R1 - T - R2, the weighted average of the SRTT to be used in the comparison of the performance of the candidate tyre shall be taken to be:
- $$\text{wa}(\text{SRTT}) = (\text{R}_1 + \text{R}_2)/2$$
- Where:
- R₁ is the mean fully developed deceleration for the first test of the SRTT and R₂ is the mean mfdd for the second test of the SRTT.
- In the case of the order of testing R1 - T1 - T2 - R2, the weighted average (wa) of the SRTT to be used in the comparison of the performance of the candidate tyre shall be taken to be:
- wa (SRTT) = 2/3 R₁ + 1/3 R₂ for comparison with the candidate tyre T1; and:
- wa (SRTT) = 1/3 R₁ + 2/3 R₂ for comparison with the candidate tyre T2.
- 3.4.1.3. The snow grip index (SG) in per cent of a candidate tyre shall be computed as:
- $$\text{Snow Grip Index (candidate)} = \frac{\text{Mean (candidate)}}{\text{wa (SRTT)}}$$
- 3.4.2. Statistical validations
- The sets of repeats of measured or computed mfdd for each tyre should be examined for normality, drift, eventual outliers.
- The consistency of the means and standard-deviations of successive braking tests of SRTT should be examined.

The means of two successive SRTT braking tests shall not differ by more than 5 per cent.

The coefficient of variation of any braking test shall be less than 6 per cent.

If those conditions are not met, tests shall be performed again after re-grooming the test course.

3.4.3. In the case where the candidate tyres cannot be fitted to the same vehicle as the SRTT, for example, due to tyre size, inability to achieve required loading and so on, comparison shall be made using intermediate tyres, hereinafter referred to as "control tyres", and two different vehicles. One vehicle shall be capable of being fitted with the SRTT and the control tyre and the other vehicle shall be capable of being fitted with the control tyre and the candidate tyre.

3.4.3.1 The snow grip index of the control tyre relative to the SRTT (SG1) and of the candidate tyre relative to the control tyre (SG2) shall be established using the procedure in paragraphs 3.1. to 3.4.2. above.

The snow grip index of the candidate tyre relative to the SRTT shall be the product of the two resulting snow grip indices that is $SG1 \times SG2$.

3.4.3.2. The ambient conditions shall be comparable. All tests shall be completed within the same day.

3.4.3.3. The same set of control tyres shall be used for comparison with the SRTT and with the candidate tyre and shall be fitted in the same wheel positions.

3.4.3.4. Control tyres that have been used for testing shall subsequently be stored under the same conditions as required for the SRTT.

3.4.3.5. The SRTT and control tyres shall be discarded if there is irregular wear or damage or when the performance appears to have been deteriorated.

4. Acceleration method for Class C3 tyres

4.1. According to the definition of C3 tyres reported into paragraph 2.4.3. above, the additional classification for the purpose of this test method only applies:

(a) C3 Narrow (C3N), when the C3 tyre nominal section width is lower than 285 mm

(b) C3Wide (C3W), when the C3 tyre nominal section width is greater or equal to 285 mm

4.2. Methods for measuring snow grip index

Snow performance is based on a test method by which the average acceleration in an acceleration test, of a candidate tyre is compared to that of a standard reference tyre.

The relative performance shall be indicated by a snow grip index (SG).

When tested in accordance with the acceleration test in paragraph 4.7. below, the average acceleration of a candidate snow tyre shall be at least 1.25 compared to one of the two equivalent SRTTs – ASTM F 2870 and ASTM F 2871.

- 4.3. Measuring equipment
- 4.3.1. A sensor suitable for measuring speed and distance covered on snow/ice surface between two speeds must be used.
- To measure vehicle speed, a fifth wheel or non-contact speed-measuring system (including radar, GPS ...) shall be used.
- 4.3.2. The following tolerances shall be respected:
- (a) For speed measurements: ± 1 per cent (km/h) or 0.5 km/h whichever is greater.
- (b) For distance measurements: $\pm 1 \times 10^{-1}$ m
- 4.3.3. A display of the measured speed or the difference between the measured speed and the reference speed for the test is recommended inside the vehicle so that the driver can adjust the speed of the vehicle.
- 4.3.4. For Acceleration test covered in paragraph 4.7. below, a display of the slip ratio of the driven tyres is recommended inside the vehicle and shall be used in the particular case of paragraph 4.7.2.1.1. below.

The slip ratio is calculated by

$$\text{Slip Ratio \%} = \left[\frac{\text{Wheel Speed} - \text{Vehicle Speed}}{\text{Vehicle Speed}} \right] \times 100$$

- (a) Vehicle speed is measured as defined in 4.3.1. above (m/s)
- (b) Wheel speed is calculated on a tyre of the driven axle by measuring its angular velocity and its loaded diameter

$$\text{Wheel Speed} = \pi \times \text{loaded diameter} \times \text{angular speed}$$

Where, $\pi = 3.1416$ (m/360deg), the loaded diameter (m) and the angular speed (revolution per second = 360 deg/sec).

- 4.3.5. A data acquisition system can be used for storing the measurements.
- 4.4. General conditions
- 4.4.1. Test course
- The test shall be done on a flat test surface of sufficient length and width, with a maximum 2 per cent gradient, covered with packed snow.
- 4.4.1.1 The snow surface shall be composed of a hard packed snow base at least 3 cm thick and a surface layer of medium packed and prepared snow about 2 cm thick.
- 4.4.1.2. The snow compaction index measured with a CTI penetrometer shall be between 80 and 90. Refer to the appendix of ASTM F1805 for additional details on measuring method.
- 4.4.1.3. The air temperature, measured about one meter above the ground, shall be between -2 °C and -15 °C; the snow temperature, measured at a depth of about one centimeter, shall be between -4 °C and -15 °C.

Air temperature shall not vary more than 10 deg C during the test.

- 4.5. Tyres preparation and break-in
- 4.5.1. Fit the test tyres on rims as per ISO 4209-1 using conventional mounting methods. Ensure proper bead seating by the use of a suitable lubricant. Excessive use of lubricant should be avoided to prevent slipping of the tyre on the wheel rim.
- 4.5.2. The tyres should be "broken-in" prior to testing to remove spew, compound nodules or flashes resulting from moulding process.
- 4.5.3. Tyres shall be conditioned at the outdoor ambient temperature at least two hours before their mounting for tests.
- They should be placed such that they all have the same ambient temperature prior to testing and be shielded from the sun to avoid excessive heating by solar radiation.
- The tyre surface in contact with snow shall be cleaned before performing a test.
- Tyre pressures shall then be adjusted to the values specified for the test.
- 4.6. Testing sequence
- If only one candidate tyre is to be evaluated, the order of testing shall be:
R1, T, R2
- Where:
- R1 is the initial test of the SRTT, R2 is the repeat test of the SRTT and T is the test of the candidate tyre to be evaluated.
- A maximum of 3 candidate tyres may be tested before repeating the SRTT test, for example: R1, T1, T2, T3, R2.
- Recommendations are that the zones where acceleration is fully applied shall not overlap without reworking and when a new set of tyres is tested;
- The runs are performed after shifting the vehicle trajectory in order not to accelerate on the tracks of the previous tyre; when it is no longer possible not to overlap full acceleration zones, the test course should be re-groomed.
- 4.7. Acceleration on snow test procedure for snow grip index of Classes C3N and C3W
- 4.7.1. Principle
- The test method covers a procedure for measuring the snow grip performance of commercial vehicle tyres during acceleration, using a commercial vehicle having a Traction Control System (TCS, ASR, etc.).
- Starting with a defined initial speed, the full throttle is applied to activate the traction control system, the average acceleration is calculated between two defined speeds.
- 4.7.2. Vehicle
- 4.7.2.1. The test shall be conducted with a standard 2 axle commercial vehicle in good running order with:

- (a) Low rear axle weight and an engine powerful enough to maintain the average percentage of slip during the test as required in paragraphs 4.7.5.1. and 4.7.5.2.1. below;
 - (b) A manual gearbox (automatic gearbox with manual shift allowed) having a gear ratio covering the speed range of at least 19 km/h between 4 km/h and 30 km/h;
 - (c) Differential lock on driven axle is recommended to improve repeatability;
 - (d) A standard commercial system controlling/limiting the slip of the driving axle during acceleration (Traction Control, ASR, TCS, etc.).
- 4.7.2.1.1. In the particular case where a standard commercial vehicle equipped with a traction control system is not available, a vehicle without Traction Control/ASR/TCS is permitted provided the vehicle is fitted with a system to display the percentage slip as stated in paragraph 4.3.4. of this annex and a mandatory differential lock on the driven axle used in accordance with operating procedure 4.7.5.2.1. below. If a differential lock is available it shall be used; if the differential lock, however, is not available, the average slip ratio should be measured on the left and right driven wheel.
- 4.7.2.2. The permitted modifications are:
- (a) Those allowing to increase the number of tyre sizes capable to be mounted on the vehicle;
 - (b) Those permitting to install an automatic activation of the acceleration and the measurements.
- Any other modification of the acceleration system is prohibited.
- 4.7.3. Vehicle fitting
- The rear driven axle may be indifferently fitted with 2 or 4 test tyres if respecting the loading by tyre.
- The front steer non driven axle is equipped with 2 tyres having a size suitable for the axle load. These 2 front tyres could be maintained along the test.
- 4.7.4. Load and inflation pressure
- 4.7.4.1. The static load on each rear driven test tyres must be between 20 per cent and 55 per cent of the tested tyre load capacity written on the sidewall.
- The vehicle front steer total static axle load should be between 60 per cent and 160 per cent of the driven rear total axle load.
- The static tyre load on the same driven axle should not differ by more than 10 per cent.
- 4.7.4.2. The driven tyres inflation pressure shall be 70 per cent of the one written on the sidewall.
- The steer tyres are inflated at nominal sidewall pressure.
- If the pressure is not marked on the sidewall, refer to the specified pressure in applicable tyre standards manuals corresponding to maximum load capacity.

- 4.7.5. Testing runs
- 4.7.5.1. Mount first the set of reference tyres on the vehicle and when on the testing area.
- Drive the vehicle at a constant speed between 4 km/h and 11 km/h and the gear ratio capable of covering the speed range of at least 19 km/h for the complete test programme (e.g. R-T1-T2-T3-R).
- The recommended gear ratio selected is 3rd or 4th and shall give a minimum 10 per cent average slip ratio in the measured range of speed.
- 4.7.5.2. In case of traction control system equipped vehicles (already switched "on" before the run) apply full throttle until the vehicle has reached the final speed.
- Final speed = Initial speed + 15 km/h
- No rearward restraining force shall be applied to the test vehicle.
- 4.7.5.2.1. In the particular case of paragraph 4.7.2.1.1. of this annex where a standard commercial vehicle equipped with a traction control system is not available, the driver shall manually maintain the average slip ratio between 10 and 40 per cent (controlled slip procedure in place of the full slip) within the prescribed range of speeds. If a differential lock is not available, the averaged slip ratio difference between the left and right driven wheel shall not be higher than 8 per cent for each run. All the tyres and runs in the test session are performed with controlled slip procedure.
- 4.7.5.3. Measure the distance between the initial speed and the final speed.
- 4.7.5.4. For every candidate tyre and the standard reference tyre, the acceleration test runs shall be repeated a minimum of 6 times and the coefficients of variation (standard deviation/average*100) calculated for minimum 6 valid runs on the distance shall be lower than or equal to 6 per cent.
- 4.7.5.5. In case of traction control system equipped vehicle, the average slip ratio shall be in the range from 10 per cent to 40 per cent (calculated as per paragraph 4.3.4. of this annex).
- 4.7.5.6. Apply testing sequence as defined in paragraph 4.6. above.
- 4.8. Processing of measurement results
- 4.8.1. Calculation of the average acceleration AA

Each time the measurement is repeated, the average acceleration AA (m · s⁻²) is calculated by

$$AA = \frac{S_f^2 - S_i^2}{2D}$$

Where D (m) is the distance covered between the initial speed S_i (m.s⁻¹) and the final speed S_f (m.s⁻¹).

4.8.2. Validation of results

For the candidate tyres:

The coefficient of variation of the average acceleration is calculated for all the candidate tyres. If one coefficient of variation is greater than 6 per cent, discard the data for this candidate tyre and repeat the test.

$$\text{coefficient of variation} = \frac{\text{stdev}}{\text{average}} \times 100$$

For the reference tyre:

If the coefficient of variation of the average acceleration "AA" for each group of min 6 runs of the reference tyre is higher than 6 per cent, discard all data and repeat the test for all tyres (the candidate tyres and the reference tyre).

In addition and in order to take in account possible test evolution, the coefficient of validation is calculated on the basis of the average values of any two consecutive groups of min 6 runs of the reference tyre. If the coefficient of validation is greater than 6 per cent, discard the data for all the candidate tyres and repeat the test.

$$\text{coefficient of validation} = \left| \frac{\text{Average2} - \text{Average1}}{\text{Average1}} \right| \times 100$$

4.8.3. Calculation of the "average AA"

If R_1 is the average of the "AA" values in the first test of the reference tyre, R_2 is the average of the "AA" values in the second test of the reference tyre, the following operations are performed, according to Table 1:

Table 1

| <i>If the number of sets of candidate tyres between two successive runs of the reference tyre is:</i> | <i>and the set of candidate tyres to be qualified is:</i> | <i>then "Ra" is calculated by applying the following:</i> |
|---|---|---|
| 1 R - T1 - R | T1 | $R_a = 1/2 (R_1 + R_2)$ |
| 2 R - T1 - T2 - R | T1 | $R_a = 2/3 R_1 + 1/3 R_2$ |
| | T2 | $R_a = 1/3 R_1 + 2/3 R_2$ |
| 3 R - T1 - T2 - T3 - R | T1 | $R_a = 3/4 R_1 + 1/4 R_2$ |
| | T2 | $R_a = 1/2 (R_1 + R_2)$ |
| | T3 | $R_a = 1/4 R_y + 3/4 R_y$ |

"T_a" (a = 1, 2, ...) is the average of the AA values for a test of a candidate tyre.

4.8.4 "AFC" Calculation (Acceleration Force Coefficient)

Also called AFC Acceleration Force Coefficient

Calculation on of AFC(T_a) and AFC(R_a) as defined in Table 2 :

Table 2

| | <i>The acceleration force coefficient "AFC" is:</i> |
|----------------|---|
| Reference tyre | $AFC(R) = \frac{R_a}{g}$ |
| Candidate tyre | $AFC(T) = \frac{T_a}{g}$ |

R_a and T_a are in m/s²

"g"= gravity acceleration (rounded to 9.81 m/s²)

4.8.5. Calculation of the relative snow grip index of the tyre

The snow grip index represents the relative performance of the candidate tyre compared to the reference tyre.

$$\text{Snow Grip Index} = \frac{AFC(T)}{AFC(R)}$$

4.8.6. Calculation of the slip ratio

The slip ratio can be calculated as the average of slip ratio as mentioned in paragraph 4.3.4. of this annex or by comparing the average distance referred to in paragraph 4.7.5.3. of this annex of the minimum 6 runs to the distance of a run done without slip (very low acceleration)

$$\text{Slip Ratio \%} = \left[\frac{\text{Average distance} - \text{No slip distance}}{\text{No slip distance}} \right] \times 100$$

No slip distance means the wheel distance calculated on a run done with a constant speed or a continuous low acceleration.

4.9. Snow grip performance comparison between a candidate tyre and a reference tyre using a control tyre

4.9.1. Scope

When the candidate tyre size is significantly different from the reference tyre a direct comparison on the same vehicle may be not possible. This is an approach using an intermediate tyre, hereinafter called the control tyre.

4.9.2. Principle of the approach

The principle lies upon the use of a control tyre and 2 different vehicles for the assessment of a candidate tyre in comparison with a reference tyre.

One vehicle can fit the reference tyre and the control tyre, the other the control tyre and the candidate tyre. All conditions are in conformity with paragraph 4.7. above .

The first assessment is a comparison between the control tyre and the reference tyre. The result (snow Grip Index 1) is the relative efficiency of the control tyre compared to the reference tyre.

The second assessment is a comparison between the candidate tyre and the control tyre. The result (snow grip index 2) is the relative efficiency of the candidate tyre compared to the control tyre.

The second assessment is done on the same track as the first one. The air temperature must be in the range of +/- 5 deg C of the temperature of the first assessment. The control tyre set is the same set as the set used for the first assessment.

The snow grip performance index of the candidate tyre compared to the reference tyre is deduced by multiplying the relative efficiencies calculated above:

$$\text{Snow Grip Index} = \text{SG1} \times \text{SG2}$$

4.9.3. Selection of a set of tyres as a control tyre set

A control tyre set is a group of identical tyres made in the same factory during one week period.

4.10. Storage and preservation

Before the first assessment (control tyre / reference tyre), normal storage conditions can be used. It is necessary that all the tyres of a control tyre set have been stored in the same conditions.

As soon as the control tyre set has been assessed in comparison with the reference tyre, specific storage conditions shall be applied for control tyres replacement.

When irregular wear or damage results from tests, or when wear influences the test results, the use of the tyre shall be discontinued.

Annex 7 - Appendix 1

Pictogram definition of "Alpine Symbol"



Minimum 15 mm base and 15 mm height.

Above drawing not to scale.

Annex 7 - Appendix 2

Test reports and test data for C1 and C2 tyres

Part 1 - Report

1. Type Approval Authority or Technical Service:
2. Name and address of applicant:
3. Test report No.:
4. Manufacturer and brand name or trade description:
5. Tyre class:
6. Category of use:
7. Snow index relative to SRTT according to paragraph 6.4.1.1.
- 7.1. Test procedure and SRTT used
8. Comments (if any):
9. Date:
10. Signature:

Part 2 - Test data

1. Date of test:
2. Location of test track:
- 2.1. Test track characteristics:

| | <i>At start of tests</i> | <i>At end of tests</i> | <i>Specification</i> |
|---------------------|--------------------------|------------------------|----------------------|
| Weather | | | |
| Ambient temperature | | | -2 °C to -15 °C |
| Snow temperature | | | -4 °C to -15 °C |
| CTI index | | | 75 to 85 |
| Other | | | |

3. Test vehicle (make, model and type, year):
4. Test tyre details.....
- 4.1. Tyre size designation and service description:
- 4.2. Tyre brand and trade description:
- 4.3. Test tyre data:

| | <i>SRTT</i> (1st test) | <i>Candidate</i> | <i>Candidate</i> | <i>SRTT</i> (2nd test) |
|----------------------------|------------------------|------------------|------------------|------------------------|
| Tyre dimensions | | | | |
| Test rim width code | | | | |
| Tyre loads F/R (kg) | | | | |
| Load index F/R (per cent) | | | | |
| Tyre pressure F/R(kPa) | | | | |

5. Test results: mean fully developed decelerations (m/s²) / traction coefficient¹

| <i>Run number</i> | <i>Specification</i> | <i>SRTT</i> (1st test) | <i>Candidate</i> | <i>Candidate</i> | <i>SRTT</i> (2nd test) |
|-------------------|----------------------|------------------------|------------------|------------------|------------------------|
| 1 | | | | | |
| 2 | | | | | |
| 3 | | | | | |
| 4 | | | | | |
| 5 | | | | | |
| 6 | | | | | |
| | | | | | |
| | | | | | |
| Mean | | | | | |
| Std-deviation | | | | | |
| CV (%) | < 6 % | | | | |
| Validation SRTT | (SRTT) < 5 % | X | X | X | |
| SRTT average | | X | X | X | X |
| Snow grip index | | 100 | | | X |

¹ Strike out what does not apply.

Annex 7 - Appendix 3

Test reports and test data for C3 tyres

Part 1 - Report

1. Type Approval Authority or Technical Service:
2. Name and address of applicant:
3. Test report No.:
4. Manufacturer and brand name or trade description:
5. Tyre class:
6. Category of use:
7. Snow grip index relative to SRTT according to paragraph 6.4.1.1.
- 7.1. Test procedure and SRTT used
8. Comments (if any):
9. Date:
10. Signature:

Part 2 - Test data

1. Date of test:
2. Location of test track:
- 2.1. Test track characteristics:

| | <i>At start of tests</i> | <i>At end of tests</i> | <i>Specification</i> |
|---------------------|--------------------------|------------------------|----------------------|
| Weather | | | |
| Ambient temperature | | | -2 °C to -15 °C |
| Snow temperature | | | -4 °C to -15 °C |
| CTI index | | | 80 to 90 |
| Other | | | |

3. Test vehicle (make, model and type, year):
4. Test tyre details
- 4.1. Tyre size designation and service description:
- 4.2. Tyre brand and trade description:
- 4.3. Test tyre data:

| | <i>SRTT (1st test)</i> | <i>Candidate 1</i> | <i>Candidate 2</i> | <i>Candidate 3</i> | <i>SRTT (2nd test)</i> |
|---------------------------|------------------------|--------------------|--------------------|--------------------|------------------------|
| Tyre dimensions | | | | | |
| Test rim width code | | | | | |
| Tyre loads F/R (kg) | | | | | |
| Load index F/R (per cent) | | | | | |
| Tyre pressure F/R (kPa) | | | | | |

5. Test results: average accelerations (m/s²)

| <i>Run number</i> | <i>Specification</i> | <i>SRTT (1st test)</i> | <i>Candidate 1</i> | <i>Candidate 2</i> | <i>Candidate 3</i> | <i>SRTT (2nd test)</i> |
|-----------------------|----------------------|------------------------|--------------------|--------------------|--------------------|------------------------|
| 1 | | | | | | |
| 2 | | | | | | |
| 3 | | | | | | |
| 4 | | | | | | |
| 5 | | | | | | |
| 6 | | | | | | |
| | | | | | | |
| | | | | | | |
| | | | | | | |
| Mean | | | | | | |
| Std-deviation | | | | | | |
| Slip ratio (per cent) | | | | | | |
| CV (per cent) | ≤ 6 per cent | | | | | |
| Validation SRTT | (SRTT) ≤ 6 per cent | | | | | |
| SRTT average | | | | | | |
| Snow index | | 1.00 | | | | |